



Multifunction LED Lighting Controller

OPPX Series

Full support for image inspection with multifunctionality and lighting brightness control

- Support for 12 V and 24 V input lighting
- Support for Mitsubishi Electric iQSS
- Recognition of individual lighting and monitoring/feedback by the new technology FALUX sensing +



Specifications

12 VDC output voltage type

Model	Capacity	Output voltage	Ethernet	No. of channels
OPPX-6012P2	60 W (30 W/channel)	12 V	-	2
OPPX-6012E2			Yes	2
OPPX-12012P4	120 W (30 W/channel)		-	4
OPPX-12012E4			Yes	4

24 VDC output voltage type

Model	Capacity	Output voltage	Ethernet	No. of channels
OPPX-10024P2	100 W (50 W/channel)	24 V	-	2
OPPX-10024E2			Yes	2
OPPX-20024P4	200 W (50 W/channel)		-	4
OPPX-20024E4			Yes	4

12 and 24 VDC output voltage compatible type

Model	Capacity	Output voltage	Ethernet	No. of channels
OPPX-1601224P4	160 W	12 V/24 V	-	4
OPPX-1601224E4			(12 V: 30 W × 2 channels, 24 V: 50 W × 2 channels)	Yes

Options

Control cables

Model	Application	Weight [g]
OP-ECBX9-3	External lighting control cable (9 open-ends with ferrule/wire markers)	190
OP-ECBX32-3	External lighting control cable (32-core flat cable with connectors)	150

Switching power supply

A 24 VDC output switching power supply is available. See P. 150 for details.



Features

Various types of lighting can be connected, allowing for unification of controllers

Lineup of 12 VDC and 24 VDC output types

The OPPX Series supports both 12 V and 24 V input lighting, and also allows connecting other companies' LED lighting units. This enables controller unification even when using multiple types of lighting units, such as general-purpose lighting and line lighting. And since communication standard unification is also possible, wiring reduction is achieved. In the case of OPPX-1601224P4/E4, both 12 and 24 VDC input lighting units can be connected using a single power supply unit.

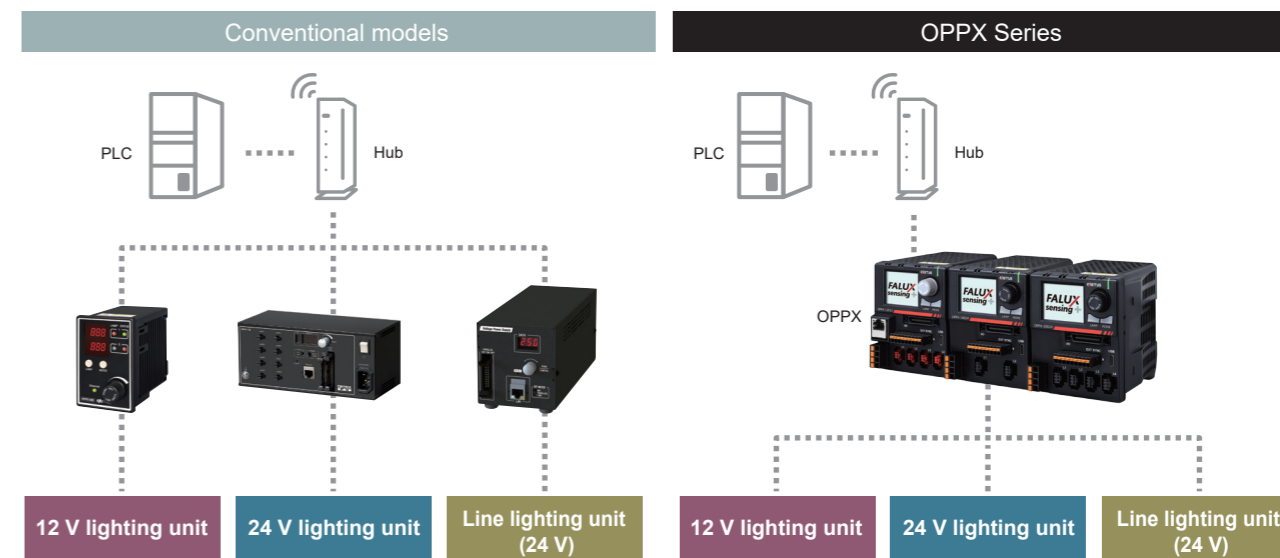

Three light intensity modes supported by all models

All models in the OPPX Series support PWM intensity control used for general-purpose lighting units and voltage intensity control suitable for line lighting units. They also support strobe overdrive that enables high-brightness lighting, so a single unit can handle various inspection applications.



Control multiple line lighting units

Single-channel light intensity control products have been the mainstream for voltage intensity control power supplies used for line lighting unit. Even if multiple lighting units were connected, the light intensity value and illumination timing could not be controlled separately.

The OPPX Series allows setting the light intensity value and illumination timing for each lighting unit, enabling control with a single controller (maximum capacity: 200 W) even when using lighting units in multiple inspection processes.

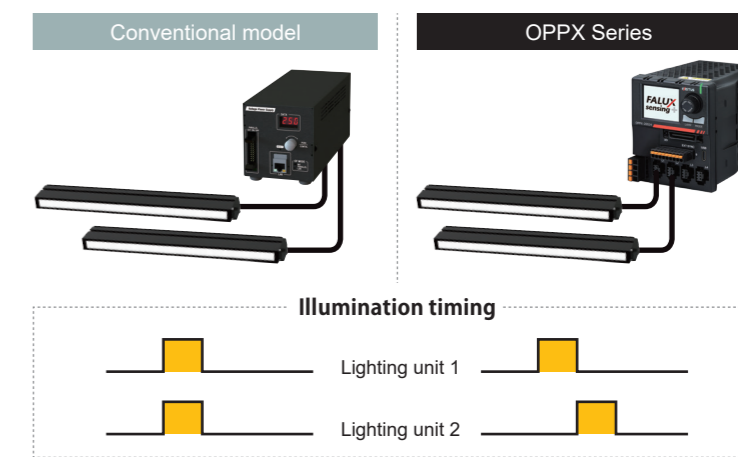



Compact case with easy-to-read LCD and fully functional controller panel

■ Compact size yet large capacity

High capacity in a compact size is achieved through high-density mounting technology and optimal heat dissipation design. Since its height is equivalent to that of the majority of PLCs (100 mm), it can be easily installed inside a panel.

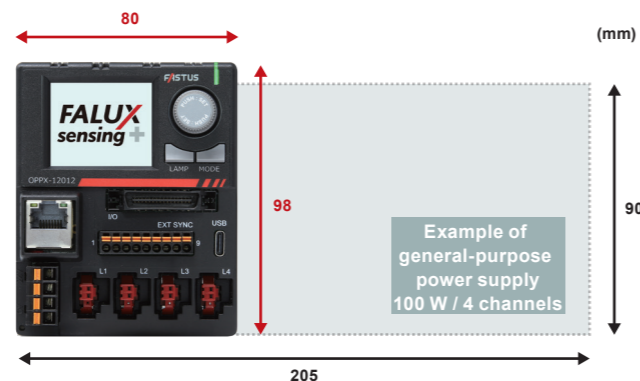

■ Fully functional controller panel

LCD

Excellent visibility with support for Japanese and English. Also allows you to check communication and other information.

Ethernet communication (OPPX-_E2/E4)

DHCP support enables automatically obtaining the IP address and IP configuration information. Simply connect a LAN cable to begin communication.

New connector type (red) for 12 VDC output
Connectors (black) for 24 VDC output



Infrared communication

Communication between units is connector-less and uses infrared. Up to 4 units can be linked together, allowing up to 16 channels to be used. A setting copy function allows settings to be batch copied to all channels.

Multi-function output terminal

Can also be used for error output, or trigger output to an imaging device.

USB port

Simply connect this port to a PC with a USB cable to use the dedicated software.

■ Also connects to existing lighting series (12 VDC specification)

The OPPX Series employs the new SM connector type. These connectors are for lighting that supports FALUX sensing+, but also allow you to connect existing lighting series (12 VDC specification, SM 2-pin connectors).



Functions to reduce the amount of work required for lighting control

■ External synchronization input assignment function

This function allows you to flexibly assign and change the output points with respect to the input points of the controller. A single input can synchronize multiple lighting units, reducing the number of wires required.

Furthermore, assignments can be changed even after wiring.

Setting example

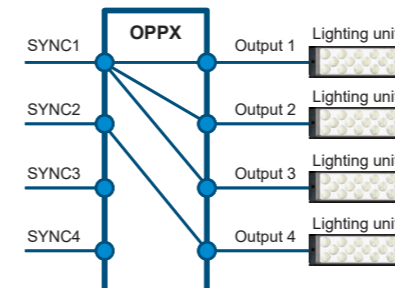

■ Sequence control

By presetting an illumination pattern for synchronization input, you can reproduce the illumination pattern with just one synchronization input.

This shortens the setup time since automatic switching is performed by only external synchronization input.

Up to 16 illumination patterns (light intensity value and illumination time) can be registered.

Sequence registration example

(illumination pattern to illuminate a workpiece from four directions)

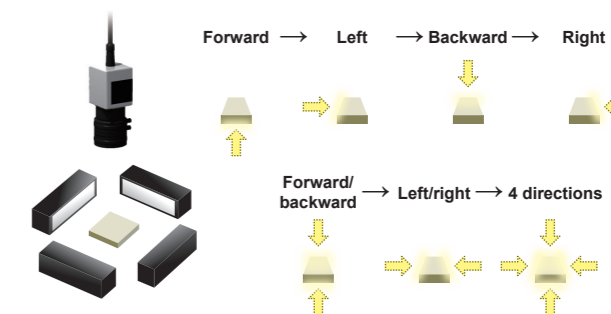

■ Recipe function

Save up to 16 illumination related settings such as the following as a recipe.

- Illumination conditions (light intensity value, illumination time, synchronization delay time, etc.)
- Sequence control settings (number of times, illumination pattern)
- Input assignment and input polarity for external synchronization control

Switching can be done quickly and easily without missing any changes as all related setting values can be switched. In addition, a backup file can be made of all settings including a recipe. The backup file can be used not just for recovery but also when adding a production line.

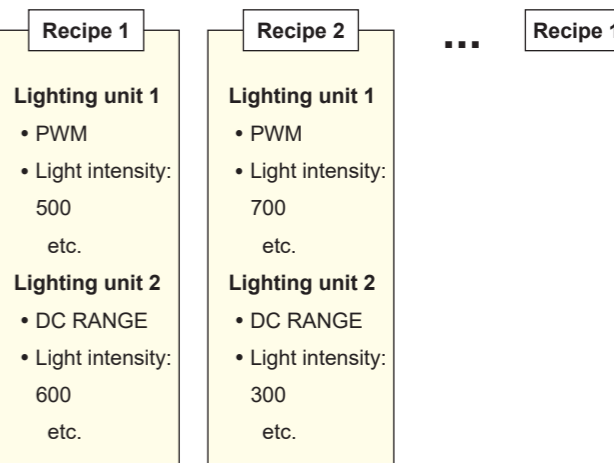

Example: Simplifying setting changes during product changeover



Examples of items that need to be changed

8 types of setting values × 4 lighting units = 32 items

- ① MODE
- ② PWM FREQ
- ③ FEEDBACK
- ④ DC RANGE
- ⑤ INTENSITY
- ⑥ WIDTH / unit
- ⑦ SEQUENCE
- ⑧ DELAY / DELAY units

With OPPX, you only need to change one recipe

- Shorten rewriting time
- Prevent rewriting mistake

	Conventional model	OPPX
Item to change	32 of the items on left	Recipe with 32 items registered
No. of changes	32	1



Optex FA's original FALUX sensing technology developed since 2010 has evolved Total brightness control can now be achieved through recognition of individual lighting units

Serial numbers and total illumination time can be viewed

The OPPX Series is equipped with the new technology FALUX sensing +. Connecting lighting units that support FALUX sensing + enables recognition of individual lighting units in addition to monitoring and feedback control. Data such as total illumination time, which differs for each individual lighting unit, can be viewed and then used for predictive maintenance.

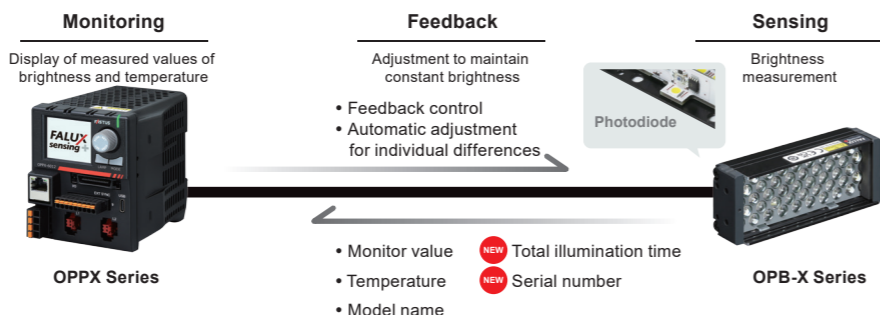

Main functions

Monitoring

The photodiode inside the lighting unit receives the light from the lighting unit itself and displays the brightness and temperature as the monitor value on the controller.

Viewable items

- Light intensity value
- Internal temperature
- Monitor value (brightness)
- Model name
- LAMP intensity correction value
- Serial number*
- Temperature
- Total illumination time*

Monitor brightness alarm

An alarm can be output when the monitor value exceeds the threshold set for the upper/lower alarm limit.

Automatic adjustment for individual differences

By setting the same absolute brightness value among all lighting units, light with the same brightness can be emitted without individual differences. Automatic or manual adjustment can be selected, and the brightness is adjusted by changing the light intensity value.

Feedback

If the brightness is reduced due to a voltage drop caused by cable extension or LED degradation, the output voltage is automatically corrected to maintain the brightness at the time of factory shipment. The offset value can be checked with the "Light intensity correction value."

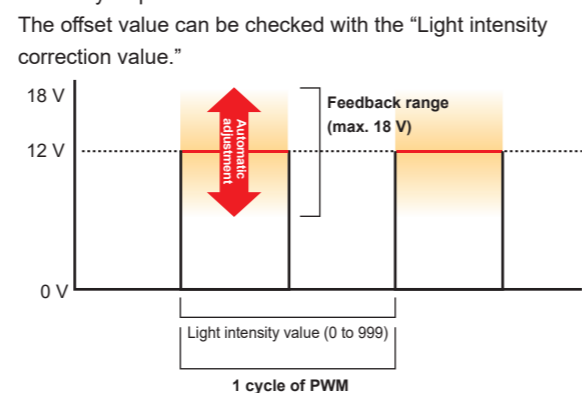

Items with * can be checked only when connected with a lighting unit that supports FALUX sensing +.

Example of using FALUX sensing+: Individual lighting control

The following items can be acquired when connected with a lighting unit that supports FALUX sensing +.

- Serial number
- Total illumination time

Since the information is saved in the lighting unit, it can also be checked when connected to another OPPX.

Even if lighting units are swapped between equipment or new lighting units are added, which lighting units are currently connected can be checked from the host PLC and utilized for equipment management.

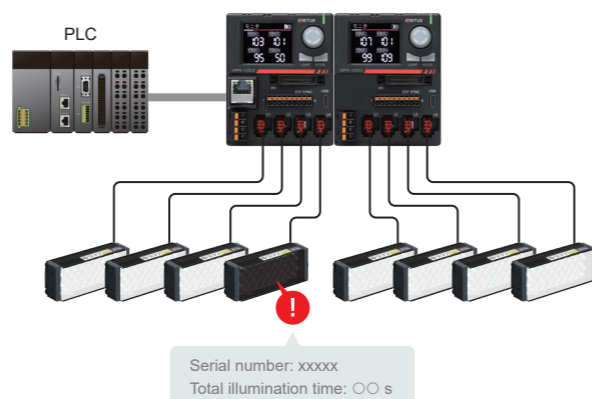

New light intensity mode L-INT prevents a decrease in brightness caused by a voltage drop due to a cable

When a lighting extension cable is used, there will be a decrease in lighting brightness caused by the voltage drop effect due to the cable. L-INT mode, a new light intensity mode, has been developed and incorporated into the OPPX Series to solve this issue. L-INT is a original light intensity mode to change brightness inside lighting units that support FALUX sensing +.

Previous issue

Even if the same light intensity value was set on previous controllers, differences in lighting brightness would occur due to differences in cable length.

When using voltage intensity control mode of OPPX

The brightness of the lighting unit is changed in proportion to the output voltage of the power supply. For OPPX with the 12 VDC output specification, the output voltage is adjusted from 8 to 12 VDC in 1,000 steps. When an extension cable is used, brightness decreases because the voltage actually applied to the lighting unit decreases compared with the output voltage of OPPX.

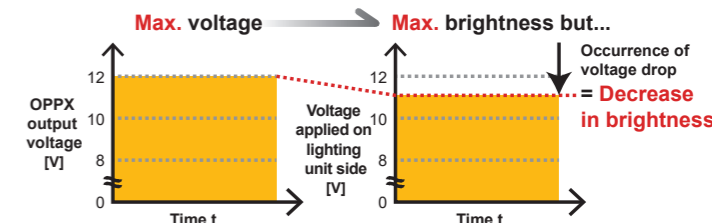

Solution implemented by new light intensity mode L-INT

L-INT provides a solution to the voltage drop effect caused by a cable. This enables illumination at the same brightness even when the cable length differs due to the way cables are routed inside the equipment.

When using the L-INT mode

Unlike with the voltage intensity control mode, the output voltage of the power supply is fixed to the maximum value regardless of the light intensity value. For OPPX with the 12 VDC output specification, the output voltage is fixed to 12 VDC, and the voltage is controlled inside the lighting unit so that a current flows to the LED according to the light intensity value set using the dedicated line communication of FALUX sensing +. This enables reducing the decrease in brightness caused by a voltage drop due to an extension cable.

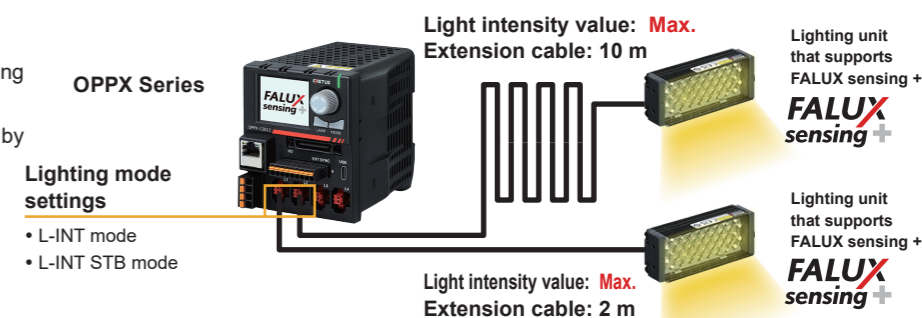
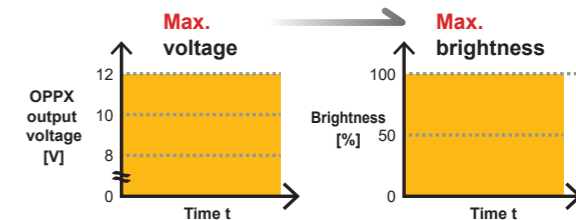

Reduction in the decrease in brightness caused by a voltage drop due to an extension cable

Voltage intensity control mode

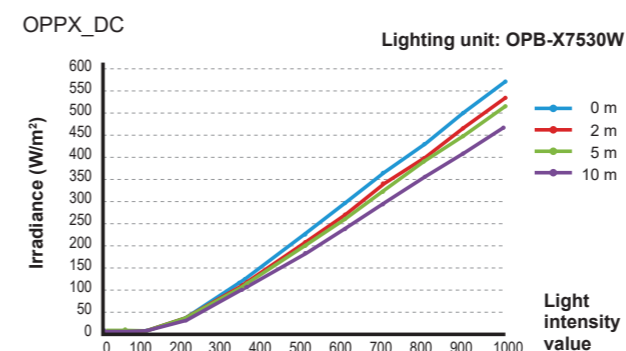

The voltage drop caused by the cable affects the lighting unit, causing the brightness to decrease. Since the level of a voltage drop differs depending on the cable length, the brightness also differs.

L-INT mode

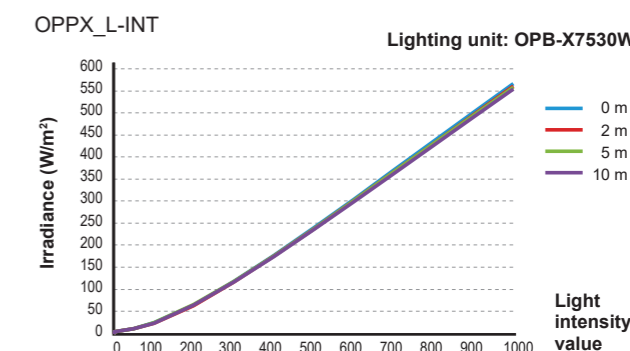

Even if there is any voltage drop due to cables, the voltage is controlled inside the lighting unit, so any differences in voltage drop due to cable length is alleviated to achieve stable brightness.



Easy setup with PC software

PC software designed specifically for the OPPX Series is available. It allows you to easily configure light intensity and synchronization control, frequency, and other settings. The software can be downloaded free of charge from the website.

Intuitive interface

Optex FA developed an interface to allow you to view light intensity and synchronization control settings at a glance. Setting values are easy to configure, with both selection from a pull-down menu and direct input supported.

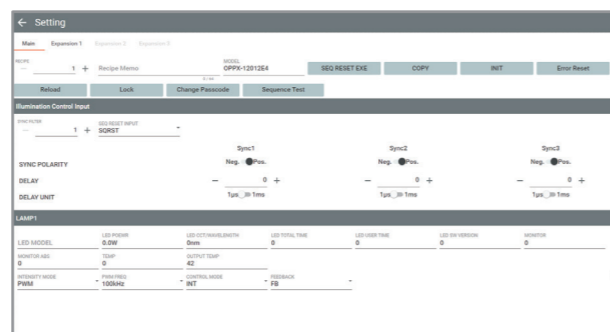

Illumination condition setting screen

Configurable items

- PWM frequency
- External synchronization input selection
- Light intensity value / lighting width
- Synchronization delay time
- External synchronization input assignment
- Sequence control
- Recipe settings
- Feedback ON/OFF
- Absolute brightness control ON/OFF

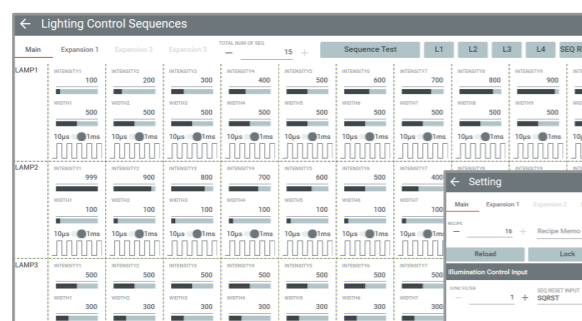

Sequence control setting screen

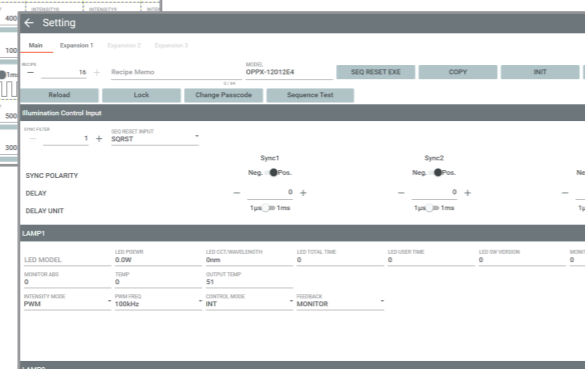

Recipe setting screen

Support for Mitsubishi Electric iQ Sensor Solution (iQSS)

The OPPX Series can be operated on a network using Mitsubishi Electric GX Works2 and GX Works3. By connecting and coordinating lighting units and power supplies for image processing, programmable controllers, displays, and other control devices, you can manage them all at once, which can be expected to bring improvements in work efficiency.

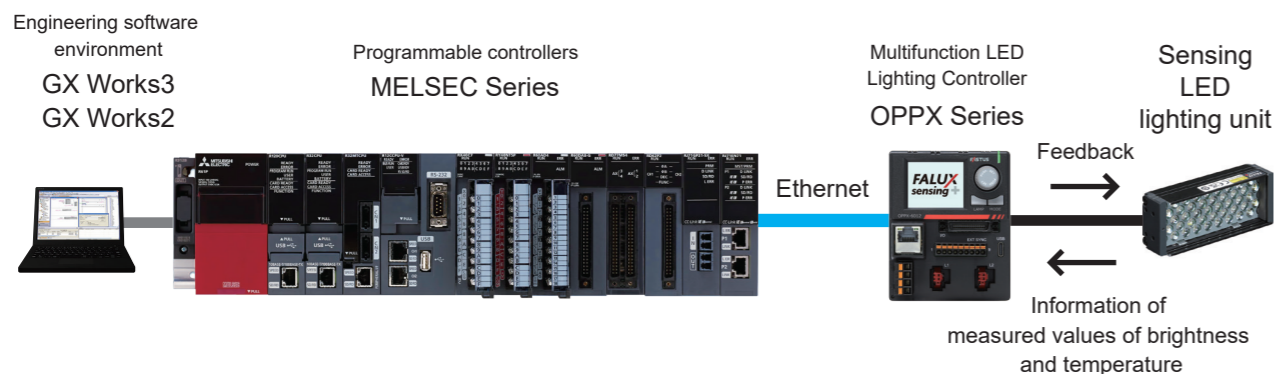

Required 24 VDC power supply capacity for power consumption of lighting unit

Based on the total power consumption of the LED lighting unit to be connected, select a 24 VDC power supply that offers more than the required capacity. See the graph on the right.

Required 24 VDC power supply capacity versus lighting unit power consumption (for OPPX-20024)

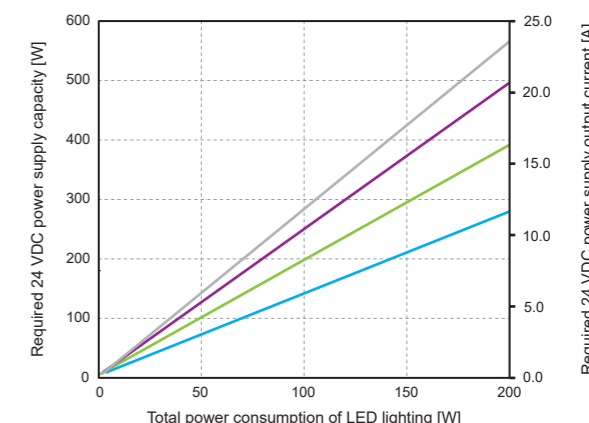

— PWM (feedback control: ON) — Strobe (feedback control: ON)
— PWM (feedback control: OFF) — Strobe (feedback control: OFF)

Note: When using in conjunction with other equipment, the characteristics of the other equipment will affect the power supply, so be sure to choose a power supply that has a sufficient margin (about twice as much) as that shown in the table.

Switching power supply

A 24 VDC output switching power supply is available. Refer to the following and then contact sales staff for details.

Power supply specifications				Connected lighting capacity of OPPX	
Output power	Output current	Rated output voltage	Rated input voltage	Feedback setting	Total power consumption of connected lighting
240 W	10 A	24 VDC ±1%	100 to 240 VAC	No	172 W ≤
				Yes	120 W ≤
480 W	20 A	24 VDC ±1%	100 to 240 VAC	No	172 W >
				Yes	120 W >

*The total power consumption of connected lighting is for PWM intensity control.

OPPX lighting extension cable combinations

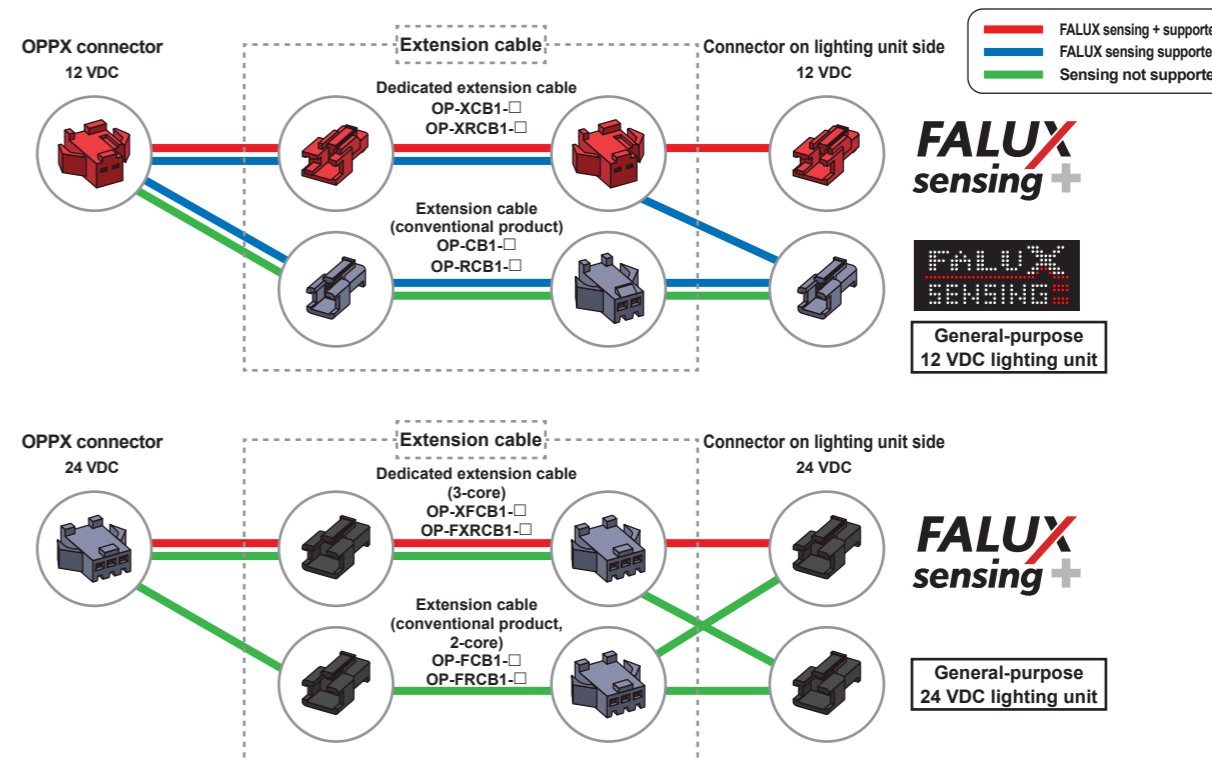



I/O function list

External illumination control connector (included accessory)

Compatible wire: 0.2 to 1.3 mm², AWG 24 to 16
 Length of stripping part: 9 to 10 mm, Terminal specification: Push-in
 Dedicated cable model: OP-ECBX9-3 (sold separately)

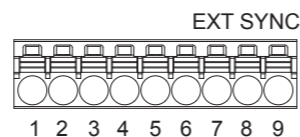

• Pin assignment

Pin No.	Name	Input/output	Signal name	Explanation of signal name
1	SYNC1	Input	External synchronization input 1	The lamp illuminates while this input is ON. When the illumination time is specified, the lamp illuminates for the specified time following brightness rise. The subject lamp can be selected via the settings.
2	SYNC2	Input	External synchronization input 2	
3	SYNC3	Input	External synchronization input 3	
4	SYNC4	Input	External synchronization input 4	
5	SEQRST	Input	Sequence reset input	Not used for external synchronization control.
6	COMINB	-	Input COM	This is the input common terminal. Each input can be turned ON by applying 5 - 24 V between the input and this common terminal. (No polarity)
7	USER1	Output	Multi-function output 1	This is a multi-function output pin. It is possible to set the output contents. It is the same as USER1 on the external parallel connector.
8	USER2	Output	Multi-function output 2	This is a multi-function output pin. It is possible to set the output contents. It is the same as USER2 on the external parallel connector.
9	COMOUTB	-	Output COM	This is the output common terminal. When output is ON, current flows from the output to this common terminal.

External parallel connector

Applicable connector: HIROSE FX2-32PA insulation-displacement connector with lock
 Dedicated cable model: OP-ECBX32-3 (sold separately) (open-ends at one end: 3 m)

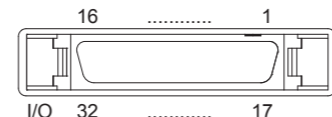

Pin No.	Name	Input/output	Signal name	Explanation of signal name
1	D0	Input	Light intensity bit 0	Inputs the light intensity value or the illumination time. Writing is performed using the BRTWR or PLSWR signal in combination with the specified station number. The recipe number can also be switched by changing the input mode.
2	D1	Input	Light intensity bit 1	
3	D2	Input	Light intensity bit 2	
4	D3	Input	Light intensity bit 3	
5	D4	Input	Light intensity bit 4	
6	D5	Input	Light intensity bit 5	
7	D6	Input	Light intensity bit 6	
8	D7	Input	Light intensity bit 7	
9	D8	Input	Light intensity bit 8	
10	D9	Input	Light intensity bit 9	
11	L0	Input	LAMP switching 0	Specifies the lamp station number for performing light intensity adjustment. The value is specified in binary.
12	L1	Input	LAMP switching 1	
13	L2	Input	LAMP switching 2	
14	L3	Input	LAMP switching 3	
15	BRTWR	Input	Light intensity value writing	Writes the light intensity bit as the light intensity value (or recipe number).
16	COMINA	-	Input COM	This is the input common terminal. Each input can be turned ON by applying 5 - 24 V between the input and this common terminal. (No polarity)
17	RXD	Input	RS-232C receive data	This is the RS-232C receive data.
18	TXD	Output	RS-232C transmit data	This is the RS-232C transmission output.
19	SG	-	RS-232C signal ground	This is the RS-232C common terminal.
20	PLSWR	Input	Illumination time write	Writes the light intensity bit as the illumination time.
21	MASK	Input	Writing mask	When ON, controls the write signal (BRTWR, PLSWR) input.
22	USER1	Output	Multi-function output 1	This is a multi-function output pin. It is possible to set the output contents. It is the same as external illumination control connector USER1.
23	USER2	Output	Multi-function output 2	This is a multi-function output pin. It is possible to set the output contents. It is the same as external illumination control connector USER2.
24	USER3	Output	Multi-function output 3	This is a multi-function output pin. It is possible to set the output contents.
25	USER4	Output	Multi-function output 4	
26	USER5	Output	Multi-function output 5	
27	USER6	Output	Multi-function output 6	
28	COMOUTA	-	Output COM	This is the output common terminal. When output is ON, current flows from the output to this common terminal.
29	SYNC1	Input	External synchronization input 1	Can be used to control lighting illumination. Selecting the external synchronization input can change the corresponding lighting.
30	SYNC2	Input	External synchronization input 2	
31	SYNC3	Input	External synchronization input 3	
32	SYNC4	Input	External synchronization input 4	



Connection to external device

NPN connection (sink connection)

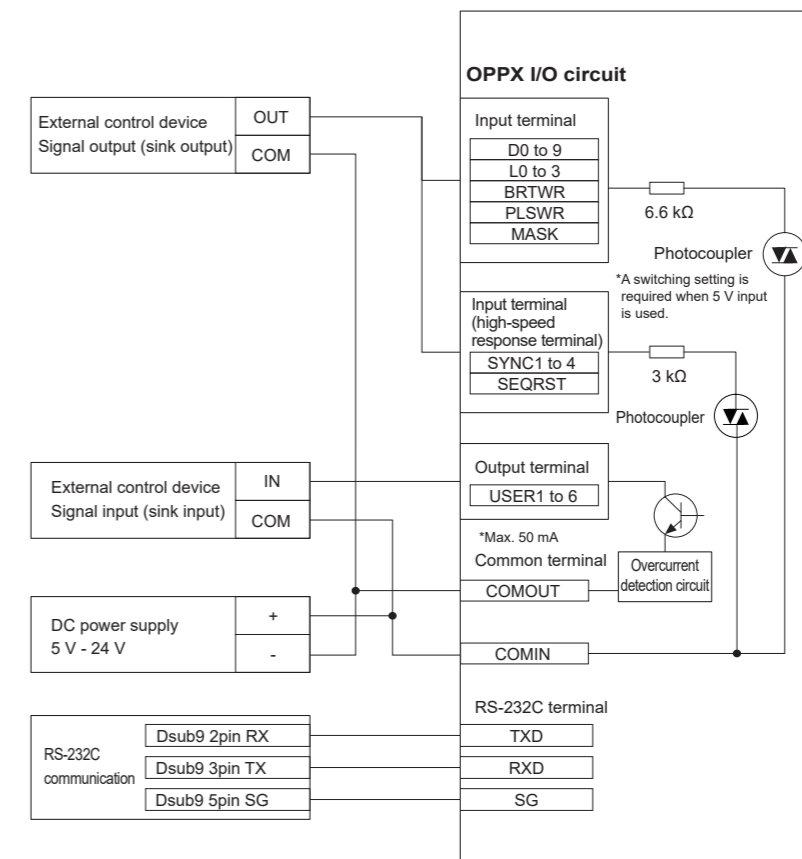

PNP connection (source connection)

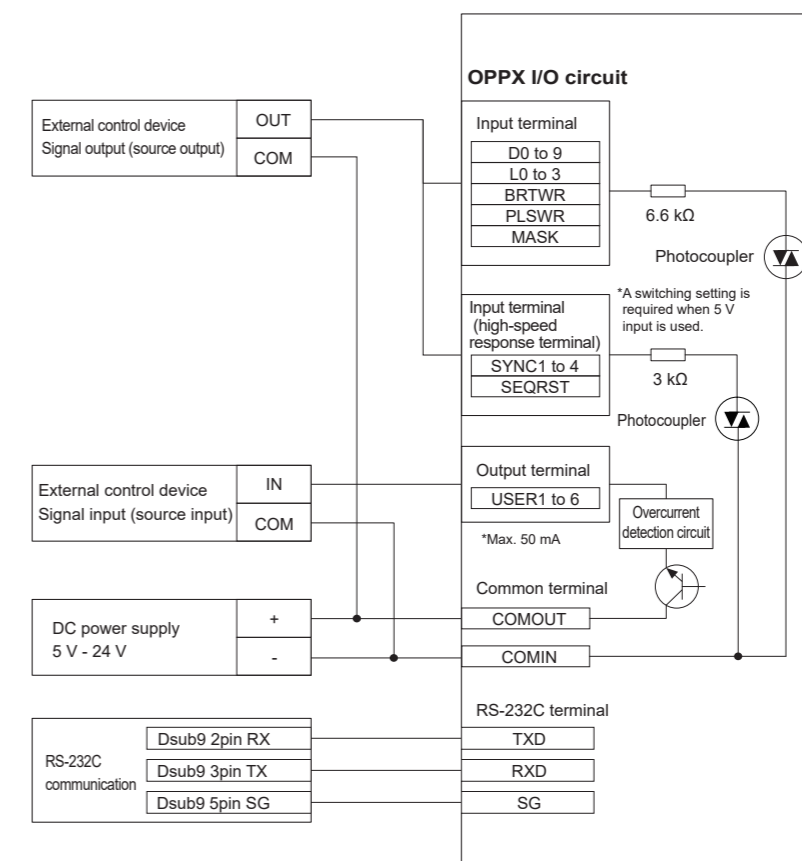



Specifications

Model	Without Ethernet	OPPX-6012P2	OPPX-12012P4	OPPX-1601224P4	OPPX-10024P2	OPPX-20024P4
	With Ethernet	OPPX-6012E2	OPPX-12012E4	OPPX-1601224E4	OPPX-10024E2	OPPX-20024E4
Supply voltage	24 VDC ±10%					
Output channels	2 ch	4 ch	2 ch (L1, L2)	2 ch (L3, L4)	2 ch	4 ch
Connectable illumination ratings	All channels max.	60 W	120 W	60 W	100 W	200 W
	Max. per channel	30 W/ch			50 W/ch	
Lighting output voltage	PWM mode	12 VDC (standard)			24 VDC (standard)	
	STB mode*1	18 VDC			48 VDC	
	DC mode	8 to 12 VDC			Low: 12 to 24 V, High: 18 to 24 V	
	L-INT mode	12 VDC			24 VDC	
	L-INT STB mode*1	18 VDC			36 VDC	
Lighting output current	PWM / DC / L-INT mode	2.5 A/ch			2.0 A/ch	
	STB / L-INT STB mode	8.0 A/ch (duty 10%)			5.0 A/ch (duty 7%)	
Light intensity	PWM intensity control, Frequency: 50 kHz, 100 kHz, 130 kHz Voltage variable mode			PWM intensity control, Frequency: 100 kHz, 130 kHz Voltage variable mode		
	Strobe	Illumination time*1	When PWM frequency 50 kHz is set: 20 μs to 19980 μs (in 20 μs steps), 1 ms to 999 ms (1 ms steps) When PWM frequency 100 kHz and 100 kHz DC are set: 10 μs to 9990 μs (in 10 μs steps), 1 ms to 999 ms (1 ms steps) When PWM frequency 130 kHz DC is set: 7.7 μs to 7684.6 μs (in 7.7 μs steps), 1 ms to 999 ms (in 1 ms steps) *When 1 ms is exceeded: Driven at 12 VDC for 12 V type, and 24 VDC for 24 V type			
Flash cycle limit			10% Duty (10 times or more than the required pulse width cycle)	7% Duty (14.3 times or more than the required pulse width cycle)		
Input	External synchronization control pin (SYNC1 to 4, SEQRST)	When 5 V SYNC is OFF	ON voltage: 12 to 24 V, OFF voltage: 1 V or less Response time: OFF → ON within 2 μs, ON → OFF within 12 μs			
		When 5 V SYNC is ON	ON voltage: 5 to 24 V, OFF voltage: 1 V or less Response time: OFF → ON within 86 μs, ON → OFF within 22 μs			
	External parallel control pin					
Output	Multi-function outputs with customizable content: 6 points Photocoupler open collector output Max. 50 mA / 30 VDC, residual voltage 1.5 V (when 10 mA)					
Communication interfaces	USB (Full-speed, Type-C connector)	Serial communication by virtual COM port				
	RS-232C	4800/9600/19200/38400/57600/115200 bps				
	Ethernet (10BASE-T/100BASE-TX) *Only installed in OPPX-□□□□E□	UDP, TCP, DHCP, and iQSS (Mitsubishi Electric iQ Sensor Solution)				
Ambient temperature/humidity	0 to 40°C / 20 to 85% RH (no condensation)					
Storage temperature/humidity	-20 to 70°C / 20 to 95% RH (no condensation)					
Vibration resistance	10 to 55 Hz, double amplitude 1.5 mm; 2 hours in each of the X, Y, and Z directions					
Shock resistance	Approx. 10 G, 3 times in each of the X, Y, and Z directions					
Material	Polycarbonate					
Weight	2 ch type: 260 g, 4 ch type: 360 g					
Degree of protection	IP20 (IEC 60529)					

Model	Without Ethernet	OPPX-6012P2	OPPX-12012P4	OPPX-1601224P4	OPPX-10024P2	OPPX-20024P4
	With Ethernet	OPPX-6012E2	OPPX-12012E4	OPPX-1601224E4	OPPX-10024E2	OPPX-20024E4
Applicable regulations	EMC*2	EU EMC directive (2014/30/EU) UK directive EMC (The Electromagnetic Compatibility Regulations 2016)				
	Environment	EU RoHS directive (2011/65/EU), China RoHS (MIIT Order No.32) UK RoHS (The Restriction of the Use of Certain Hazardous Substances in Electrical and Electronic Equipment Regulations 2012)				
Applicable standards	EN IEC 61326-1 (Group 1, Class A according to EN 55011)					
Design life	7 years (maximum load, 24 hours continuous use, 40°C environment)					
Accessories	External illumination control connector, power connector, instruction manual					

*1 If the strobe illumination time exceeds 1 ms, the 12 V type will be driven at 12 VDC, and the 24 V type will be driven at 24 VDC.
*2 If the light intensity value is set to 900 or higher, noise may increase depending on the user's cable wiring conditions.
In that case, attach a ferrite core to the end of the lighting output cable on this product side.
Recommended ferrite core: NFT-13S (Manufactured by TAKEUCHI INDUSTRY CO., LTD. Maximum cable diameter: 13.5 mm)

Dimensions

(Unit: mm)

