



*Good Thinking, Good Future*

\*FASTUS is a product brand of Optex FA.

## Megapixel Character Recognition Vision Sensor MVS-OCR2 Series (V3)

---

# User's manual



**OPTEX FA CO., LTD.**

Thank you for purchasing the MVS-OCR2 series Megapixel Character Recognition Vision Sensor.

This manual contains the information necessary for using this product.

Read this manual thoroughly before using the product to ensure correct product use with full understanding of the functions and performance of the product.

Also, after you have finished reading this manual, store it safely for future reference.



# Safety Precautions

In this manual, safety precautions are provided with the following text and symbols to ensure safe use of the MVS-OCR2 multi-camera vision sensor for character recognition.







The precautions listed here indicate important information pertaining to safety. Be sure to follow the precautions below.

## ■ Safety precaution symbols



The safety precaution symbols used and their meanings are listed below.

 <b>Warning</b>	Indicates that incorrect use may lead to light or moderate injury. In rare cases, incorrect use may lead to serious injury or death. Also indicates that incorrect use may lead to serious property damage.
 <b>Caution</b>	Indicates that incorrect use may lead to light or moderate injury or may lead to property damage.











## ■ Precautions

 <b>Warning</b>	
	Never disassemble, repair, modify, or incinerate this product or deform it through the application of pressure. Doing so may lead to personal injury or fire.
	Do not use this product underwater, in a location that is subject to water, or when the product is otherwise wet with water. Doing so may lead to fire or malfunction.
	This product does not have an explosion-proof construction. Never use this product in an environment in which flammable or explosive gas or liquid is present. Doing so may lead to explosion or fire.
	Do not use flammable gas, such as compressed air or other types of sprays, inside of or in the vicinity of this product. Doing so may lead to explosion or fire.
	Do not install this product and its cables in the following locations. Doing so may lead to fire, malfunction, or failure. <ol style="list-style-type: none"> <li>1. Locations in which dust, salt, iron powder, or steam (vapor) is present</li> <li>2. Locations in which corrosive or flammable gas is present</li> <li>3. Locations that are subject to sprayed liquids such as water, oil, and chemicals</li> <li>4. Locations that are subject to intense vibrations or impacts</li> <li>5. Locations in which the ambient temperature is not within the rated range</li> <li>6. Locations that are subject to sudden temperature changes (locations in which condensation forms)</li> <li>7. Locations in which strong electric or magnetic fields are present</li> <li>8. Outdoor locations or other locations that are subject to direct sunlight</li> </ol>
	Do not use the controller with a voltage that exceeds the rated voltage or with an AC power supply. Doing so may lead to fire or malfunction.







## ⚠ Warning

	<p><b>In case of smoke or other abnormality</b></p> <p>If you notice something abnormal such as smoke, a strange smell, a strange sound, or the main unit becoming extremely hot, stop using the product immediately and turn off the controller. Failing to do so may lead to fire.</p> <p>Never attempt to repair the product yourself, as doing so is dangerous. Instead, contact an Optex FA sales representative.</p>
	<p><b>If water enters into the product</b></p> <p>If water or another liquid enters into the product or its cables, stop using the product immediately and turn off the controller. Continuing to use the product in this situation may lead to fire.</p>

## ⚠ Caution

	Do not touch the product or its cables with wet hands. Doing so may lead to malfunction.
	When wiring this product or its controller, follow the procedures in this manual and in the specified instruction manuals. Incorrect wiring may lead to malfunction or failure of this product and of the controller.
	Use the included cable to connect this product to the controller. Using a different cable may lead to failure or malfunction.
	Install the wiring for this product separately from high-voltage or power circuits. Installing the wiring together with these circuits can cause induction interference, which may lead to failure or malfunction. If wiring separately is impossible, please shield the wires with a conductive material that is grounded, such as a conduit pipe.
	Install this product as far away as possible from machines that generate noise, such as high-voltage machines, power machines, machines that generate large switching surges, welding machines, and inverter motors.
	Install this product and its controller securely. For any items that have locking mechanisms, check that the locking mechanisms have been engaged before you start using the product. If the product and controller are not installed securely, they may fall, which may lead to injury or malfunction.
	Use the torque specified in this manual to tighten the mounting screws.
	Do not subject the cables to torsional stress. Doing so may lead to malfunction of the cables and their connectors. Also, install the cables in a manner that ensures they have at least the minimum bend radius (65 mm).
	Do not drop this product or subject it to strong impacts. Doing so may lead to malfunction.
	This product becomes hot during operation. Do not touch it for a long period while it is operating. Doing so may lead to low-temperature burns.

## Caution

	Use this product and its controller within their rated ranges.
	Do not turn the power off while image data is being saved to the internal memory. Doing so will corrupt the data that is being saved.
	There may be differences in the detection characteristics due to variations between different products, the inspection target, and the detection environment.
	Be sure to turn the power off before you connect or disconnect cables. Connecting or disconnecting cables while the power is on may lead to malfunction.
	Be sure to hold the connector when you connect or disconnect cables. Also, do not apply unnecessary force to the cables.
	When a connector is disconnected, do not touch the terminals inside the connector and be sure to prevent foreign materials from entering into the connector.
	When you remove the lens from this product, be sure to attach the included cap. Failing to attach the cap may lead to foreign materials entering into the product, which may lead to failure or malfunction.

## ■ Maintenance

Do not use thinner, benzene, acetone, or kerosene to clean the devices.

If a large piece of dirt or dust is affixed to the front panel, use a blower brush (for camera lenses) to blow off the debris. Do not blow off debris using your breath. Use a soft cloth (such as a lens cleaner cloth) to gently wipe off small pieces of dirt and dust.

Avoid vigorous wiping. If the product is damaged, the result may be a failure or malfunction (incorrect detections).

## ■ Handling precautions

- (1) Before installation, confirm the intended use, specifications, and operating conditions. Be sure to use this product within the specified range.
  - (2) The hardware, software, and system information included in this user's manual may be changed without notice due to factors such as technological improvements.
  - (3) Before using this product, be sure to implement the necessary safety designs relating to your hardware, software, and system in order to prevent loss of life, injury, or property damage that may arise from a failure or malfunction of this product.
  - (4) This product is not designed to be used in nuclear power, in rail transportation, in aviation, with medical equipment, with food- and beverage-related equipment, or in other applications that have special safety requirements. Never use this product in such environments.
  - (5) Do not use this product to directly or indirectly detect the human body for the purpose of ensuring safety.
  - (6) Do not use this product for the purpose of developing weapons of mass destruction, military use, or any other military applications. When exporting this product, strictly adhere to the applicable export-related laws, such as the Foreign Exchange and Foreign Trade Act of Japan and the Export Administration Regulations of the United States. Be sure to follow the procedures established by these laws.
  - (7) For details on this product's compliance with the RoHS directive, contact an Optex FA sales representative.
- Before you use this product, confirm all applicable environmental laws and use this product in a manner that complies with these laws. Optex FA accepts no liability for damages that arise from your failure to strictly adhere to the applicable laws.

# Contents



Safety Precautions .....	i
Terminology Used in This Manual .....	vii
Conventions Used in This Manual.....	ix

## 1 Product Overview

1-1 Features and Main Functions .....	1-2
1-2 System Configuration .....	1-3

## 2 Installation and Connection

2-1 Before Installation .....	2-2
2-2 Part Names and Functions .....	2-5
2-3 Installing the Camera Unit .....	2-11
2-4 Installing the Controller .....	2-12
2-5 Connecting the Camera Unit to the Controller .....	2-14
2-6 Connecting the LED Light .....	2-15
2-7 Attaching the Terminal Block .....	2-16
2-8 Selecting the Lens and Extension Ring .....	2-17

## 3 Basic Operation

3-1 About the Operation Screen .....	3-2
3-2 Basic Operations .....	3-10

## 4 Setup

4-1	Setup Flowchart .....	4-2
4-2	Standard Setup .....	4-3
4-3	Setup for Color Extraction .....	4-20

## 5 Operation

5-1	Select a Bank .....	5-2
5-2	Displaying NG Images .....	5-11
5-3	Analyzing NG Images .....	5-13

## 6 Settings

6-1	Settings .....	6-2
6-2	Configure Settings .....	6-5
6-3	Image Capture Settings .....	6-8
6-4	Cutout Settings .....	6-18
6-5	Character Recognition Settings .....	6-23
6-6	I/O Settings .....	6-47
6-7	The Inspection Window .....	6-57
6-8	Search Within Images .....	6-60
6-9	Teaching Settings .....	6-66
6-10	The Calendar Timer .....	6-68
6-11	Other Settings .....	6-69

## 7 Other Functions

7-1	Check the Hardware Version .....	7-2
7-2	Initialize Settings .....	7-3
7-3	Lock Settings with Passwords .....	7-5
7-4	Change the Display Language .....	7-10
7-5	Monitor the Operating Environment of the Camera Unit .....	7-11
7-6	Share the Recognized Character String of a Camera Unit .....	7-12
7-7	The Barcode Link Function .....	7-13

## 8 Configure Settings with Communication

8-1	Specifications .....	8-2
8-2	Configuring Ethernet Communication Settings (Only for Controllers with Ethernet Support) .....	8-24
8-3	I/O Specifications .....	8-40

## 9 Troubleshooting

9-1	Problems and Solutions .....	9-2
-----	------------------------------	-----

## 10 Appendix

10-1	Specifications .....	10-2
10-2	Dimensions .....	10-4

Index

# Terminology Used in This Manual

This section explains the terminology used in this manual.

## ■ Bank

The settings used for image capture and judgement are stored in memory "banks."

You can register up to 32 banks, from bank 1 to bank 32, for each camera unit (head). Easily load settings to match the inspection target by switching to another bank during changeover.

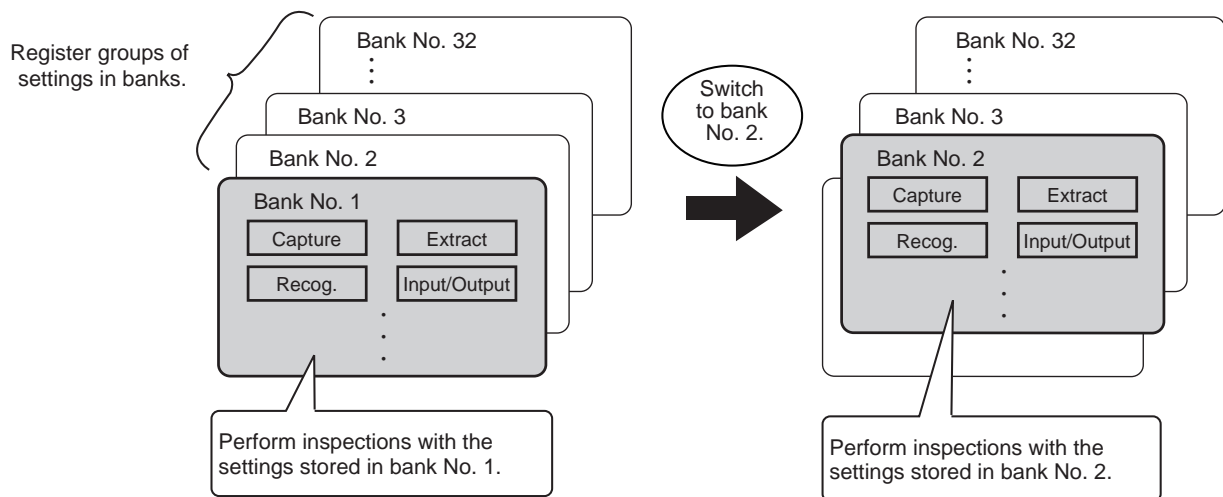

## ■ Inspection window

The area where the characters will be inspected is called the "inspection window."

You can set the inspection window to any location within the captured image. Only the alphanumeric characters within the region bounded by the inspection window are inspected.

You can set up to four inspection windows for a single bank.

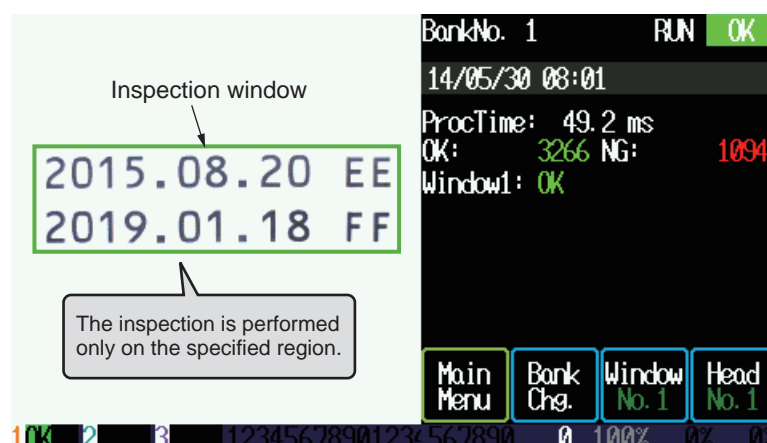

## ■ Format

The style of the target characters is called their "format."

By registering the format of information such as the date and the time and registering this format in advance, the device can automatically perform OK/NG judgment by verifying the current date and time.

You can set up to four formats for a single inspection window and select any combination of formats from those shown below.

Format	Style	Details
YYYYMD	2013.10.15	4-digit year / 2-digit month / 2-digit day
YYYYM	2013.10	4-digit year / 2-digit month
YYMD	13.10.15	2-digit year / 2-digit month / 2-digit day
YYM	13.10	2-digit year / 2-digit month
MD	10.15	2-digit month / 2-digit day
String	ABCD1234	Alphanumeric character string
Command*	—	Unique date or character string
Alph. MD*	—	Month and day encrypted as alphabet characters and numbers
Alph. M*	—	Month encrypted as alphabet characters and numbers
Alph. D*	—	Day encrypted as alphabet characters and numbers
Alph. HM*	—	Hour and minute encrypted as alphabet characters and numbers
Alph. Min*	—	Hour encrypted as alphabet characters and numbers
YYYYED	2013.OCT.15	4-digit year / 3-character month / 2-digit day
YYYYE	2013.OCT	4-digit year / 3-character month
YYED	13.OCT.15	2-digit year / 3-character month / 2-digit day
YYE	13.OCT	2-digit year / 3-character month
1Y	9 (for 2009)	1-digit or 2-digit year
HH:MM	17:30	Time with a colon between the hour and minute (24-hour clock)
HH	17 (for 17:00)	The hour
HHMM	1730 (for 17:30)	Time with no colon between the hour and minute (24-hour clock)
Alph. H+M*	—	Hour and 2-digit minute encrypted as alphabet characters and numbers

\* Use this linked with a decryption table.

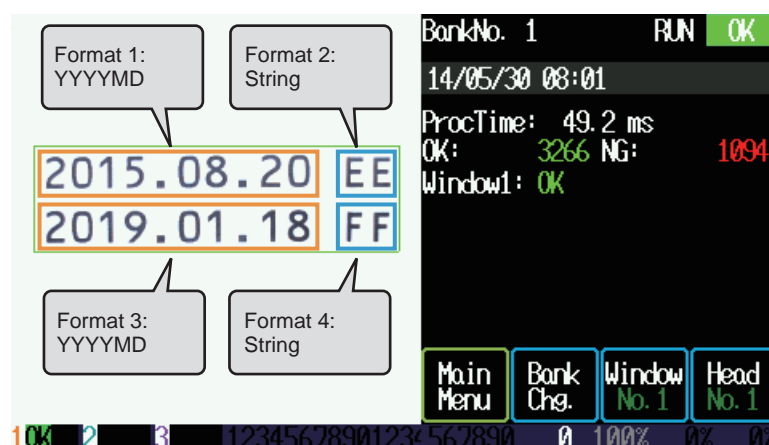

# Conventions Used in This Manual

This section explains the conventions used in this manual.

## Caution

Indicates an item that requires special attention during operation.

## MEMO

Indicates information that is useful to know during operation.

## Reference

Indicates reference information such as the operating principle of the vision sensor.

## ■ Operation keys

 : Indicates a key on the controller's numeric keypad.

[1] : Items enclosed in brackets indicate screen titles, items displayed on the touch panel, and operation buttons.

## ■ Settings

The icons below show where the device settings apply.

### ● Icons that show where settings apply

 : The settings can be configured for each bank.

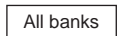
 : The settings are common to all banks.

 : The settings can be configured for each inspection window.

 : The settings apply to the controller and are included with the settings under "Etc."  
These settings do not change when settings are initialized.

## ■ Screens

Screens shown in this manual may be changed without notice for the sake of improvement.

We ask for your understanding in this matter.





---

# 1

## **Product Overview**

This chapter provides an overview of the main unit.

# 1-1 Features and Main Functions



The MVS-OCR2 is a camera vision sensor that is equipped with OCR (Optical Character Recognition) for character recognition.

The MVS-OCR2 has the following features.

- Up to four inspection windows can be created to support a variety of print formats such as dates and times of manufacture, expiration dates, and lot numbers.
- The image capture angle can be set in units of 90°, so there is no need to change the angle of the camera. Mirrored characters are also supported.
- If the character width is set in advance, characters can be recognized separately even when the space between characters is narrow.
- Up to eight consecutive images can be captured. This enables image capture when the trigger mode is not uniform or when the workpiece positions are not uniform.
- The built-in dictionary and additional extended dictionaries make it possible to accurately read a variety of symbols and lowercase alphabet letters that are difficult to recognize correctly.
- The built-in calendar timer makes it possible to automatically update inspection dates. Therefore, even if the printed date and time are updated, inspections can be automatically performed to match the updated information.

# 1-2 System Configuration

The main unit and the peripheral devices as well as the functions of each device are shown below.

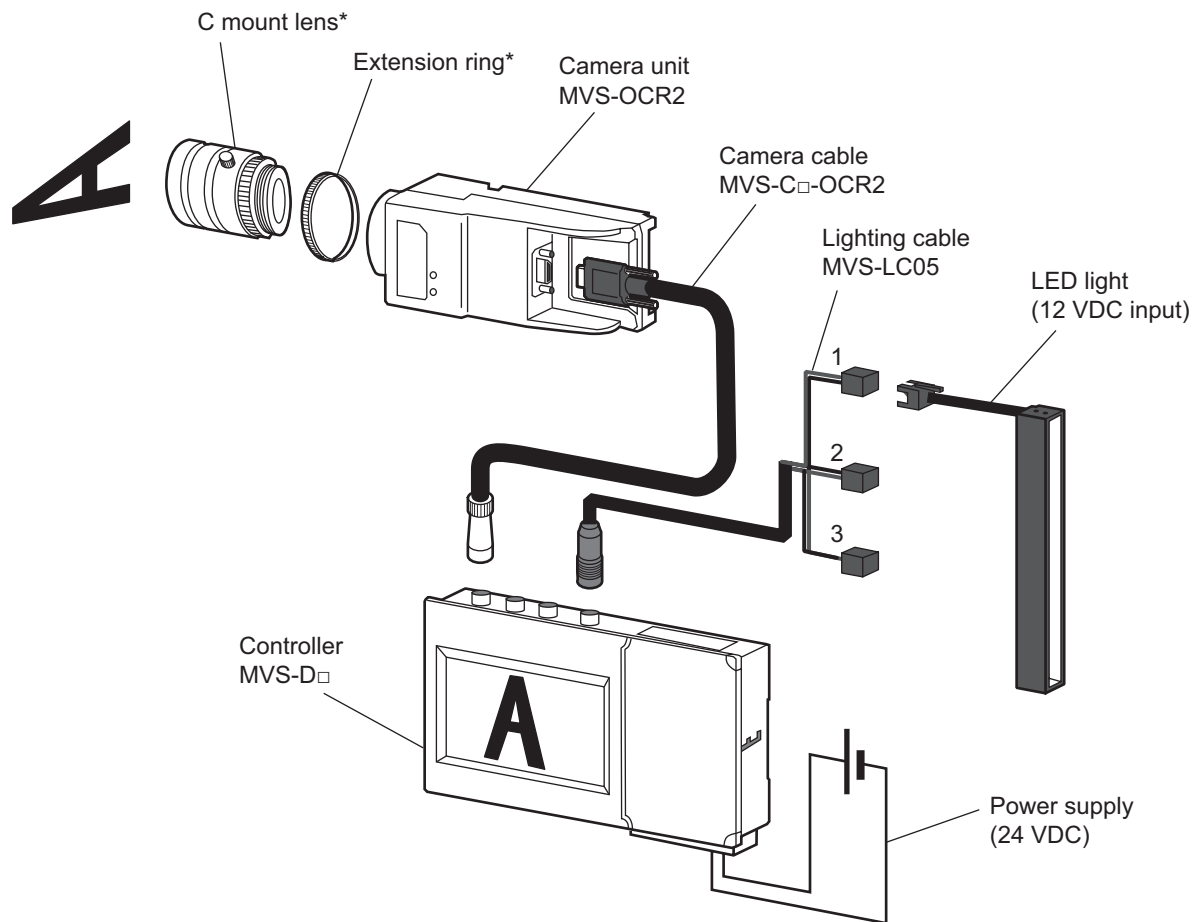

\* These items are optional. See "■ Optional items" (page 2-3), and use as required based on the environment and conditions.

Name	Function
Camera unit	The camera captures and processes the images.
Controller	The controller displays the images captured and processed by the camera unit. It is also used to view the settings and detailed information. Up to 3 camera units can be connected to the controller.
Camera cable	This cable connects the camera unit and the controller. Select a cable to match the distance between the camera unit and the controller.
LED light	The LED light emits a light to the target to stabilize the imaging state. The controller settings can be used to switch the light between always on and pulsating and to adjust the brightness.
Lighting cable	This cable connects the LED light and the controller. Up to 3 LED lights (24 W total) can be connected.
Power supply (24 VDC)	This is the power supply that drives the system. Connect the power supply to the controller's terminal block.

## ■ Options

Name	Function
C mount lens	Attaches to the camera unit to enhance image capture. See the optics charts to select a lens that matches your imaging environment. ("2-8 Selecting the Lens and Extension Ring" (page 2-17))
Extension ring	Use this ring when you want to perform close-up imaging. See the optics charts to select a ring that matches your imaging environment. ("2-8 Selecting the Lens and Extension Ring" (page 2-17))

## ■ About the controller

The following controller models are available.

Select the controller to match your operating environment and application.

Model	Details
MVS-DN	NPN output type (discontinued product)
MVS-DP	PNP output type (discontinued product)
MVS-DN-E	Standard specifications(Ethernet-compatible): NPN output type
MVS-DP-E	Standard specifications(Ethernet-compatible): PNP output type
MVS-DN-V *	Model with video output: NPN output type
MVS-DP-V *	Model with video output: PNP output type

\* This product is built to order. An Ethernet-compatible model is not available.



---

# 2

## **Installation and Connection**

This chapter gives the names of the parts and explains how to install and connect the main unit.

# 2-1 Before Installation

## ■ Package Contents

Confirm that the following items are contained in the package.

### ● Camera unit

- Camera unit ... 1

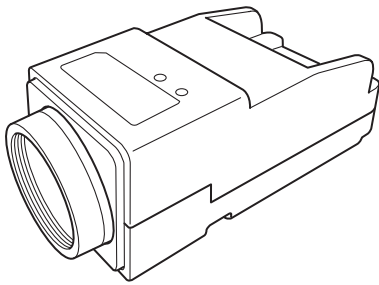

- Mounting bracket ... 1

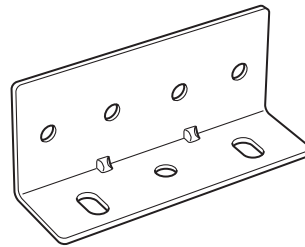

- Fixing screws ... 2

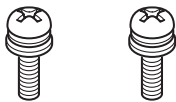

- Instruction manual ... 1

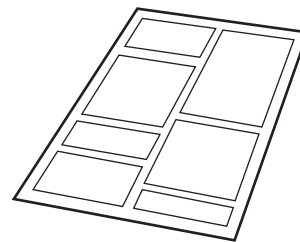

### ● Controller

- Controller ... 1

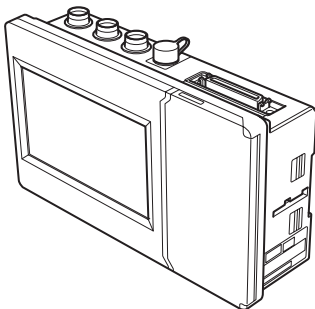

- Panel mount attachments ... 2

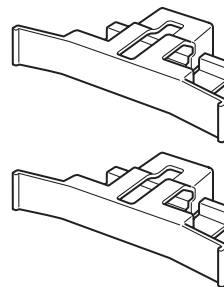

- Terminal block ... 1

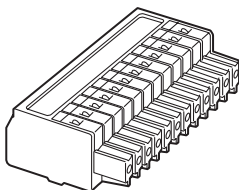

- Instruction manual ... 1

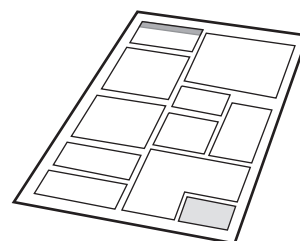

## Optional items

The following items are available depending on your operating environment and conditions.

Product name	Model	Specifications
Camera cable	MVS-C2S-OCR2	Cable length: 2 m, connector shape: straight
	MVS-C5S-OCR2	Cable length: 5 m, connector shape: straight
	MVS-C10S-OCR2*	Cable length: 10 m, connector shape: straight
	MVS-C5L-OCR2*	Cable length: 5 m, connector shape: right angle
CCTV lens (C mount)	FASV-03514V	Focal distance: 3.5 mm Brightness: F1.4
	FASV-0813V	Focal distance: 8 mm Brightness: F1.3 Filter size: M25.5 P0.5
	FASV-1214V	Focal distance: 12 mm Brightness: F1.4 Filter size: M27 P0.5
	FASV-1614V	Focal distance: 16 mm Brightness: F1.4 Filter size: M27 P0.5
	FASV-2514V	Focal distance: 25 mm Brightness: F1.4 Filter size: M27 P0.5
	FASV-5018V	Focal distance: 50 mm Brightness: F1.8 Filter size: M30.5 P0.5
Macro lens with mega-pixel support (C mount)	FASV-LDA4	Focal distance: 4 mm Brightness: F4.16 Filter size: M27 P0.5
	FASV-LDA6.5	Focal distance: 6.5 mm Brightness: F6.51 Filter size: M27 P0.5
	FASV-LDA10	Focal distance: 10 mm Brightness: F10.27 Filter size: M27 P0.5
	FASV-LDA20	Focal distance: 20 mm Brightness: F20.74 Filter size: M27 P0.5
	FASV-LDA30	Focal distance: 30 mm Brightness: F30.01 Filter size: M27 P0.5
	FASV-LDA50	Focal distance: 50 mm Brightness: F48.46 Filter size: M27 P0.5
Polarization filter	FASV-PL255-RS	Filter size: M25.5 P0.5
	FASV-PL270-RS	Filter size: M27 P0.5
	FASV-PL305-RS	Filter size: M30.5 P0.5

\* This product is built to order.

Product name		Model	Specifications
Extension ring	Extension ring set	FASV-EXR-LT2	Thickness: 0.5 mm, 1 mm, 5 mm, 10 mm, and 20 mm (set of 5 rings)
	Extension ring	FASV-EXR05	Thickness: 0.5 mm
		FASV-EXR1	Thickness: 1 mm
		FASV-EXR2	Thickness: 2 mm
LED light cable	Cable for light	MVS-LC05	Cable length: 500 mm Number of lighting units that can be connected: 3
	Extension cable for light	OP-CB1-2	Cable length: 2 m
		OP-CB1-3	Cable length: 3 m
		OP-CB1-5	Cable length: 5 m
I/O Connector cable		MVS-C3IO	Cable length: 3 m, IEEE1284 50-pin connector Discrete wires on one side

# 2-2 Part Names and Functions

This section describes the part names and functions of the camera unit and controller.

## ■ Camera unit

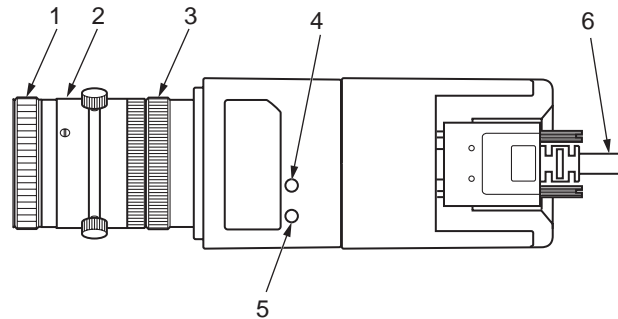

Number	Name	Function
1	Filter	Filters include polarizing filters to removal luster, light reducing filters, and glass covers for lens protection. Attach a filter to match the application.
2	C mount lens	Select a lens from the optics charts (page 2-19).
3	Extension ring	Use this ring depending on the distance to the inspection target and the field of view.
4	Power indicator	This indicator shows the camera unit's on/off status. Green light: The camera unit is on. Off: The camera unit is off.
5	Communication status indicator	This indicator shows the status of communication with the controller. Green light: The device is operating normally. Red light, blinking red light, orange light, blinking orange light, or blinking green light: Contact Optex FA.
6	Camera cable	This cable connects the camera unit and the controller.

## ■ Controller

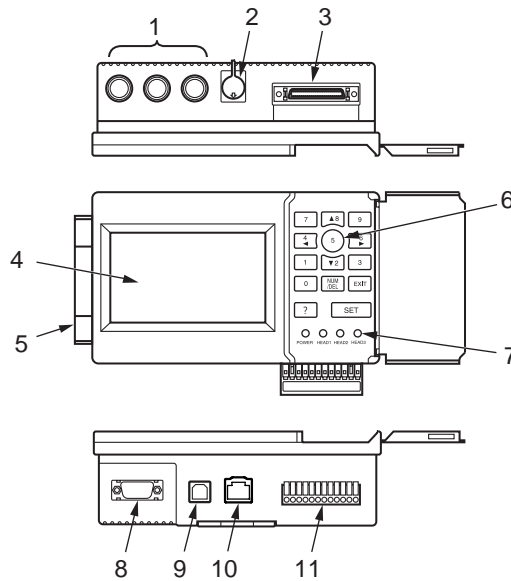

Number	Name	Function
1	Camera unit connectors	Connect the camera cables to these connectors. You can connect up to three camera units (heads).
2	LED light connector	Connect the LED light cable to this connector. The controller will supply up to 24 W of power.
3	Expansion I/O connector	This is a 50-pin expansion connector. Connect the MVS-C3IO I/O connector cable to this connector to expand functionality. For details on the function of each pin, see "• Expansion I/O connector (50-pin)" (page 2-8).
4	Touch panel	Touch the keys and items displayed on the screen to perform operations.
5	Panel mount attachment	This is a dedicated attachment for mounting the controller on a panel.
6	Numeric keypad	Use this keypad to configure settings. During configuration, the keys that can be operated are lit green.
7	Power and head connection status indicators	These indicators show the power status and the status of connections to the camera units (heads). POWER: This indicator lights green when the power is on. HEAD1 to HEAD3: These indicators light red when heads are connected.
8	RS-232C terminal	This is a D-sub 9-pin RS-232C connector. Connect an RS-232C cable to this connector to communicate with an external device. This terminal is also used to connect a barcode reader.
9	USB port	This is a USB 1.1 (type B) connector.
10	LAN port (MVS-DN-E/MVS-DP-E only)	Connect a LAN cable to this port in order to establish a LAN connection.
11	Terminal block	This is a 12-pin terminal block. It has the following functions. <ul style="list-style-type: none"> <li>• Supplies operating power</li> <li>• OK/NG judgment output</li> <li>• Capture timing (trigger) input</li> <li>• Other input</li> </ul> For details on pin functions, see "• Terminal block (12-pin)" (page 2-7).

## ● Terminal block (12-pin)

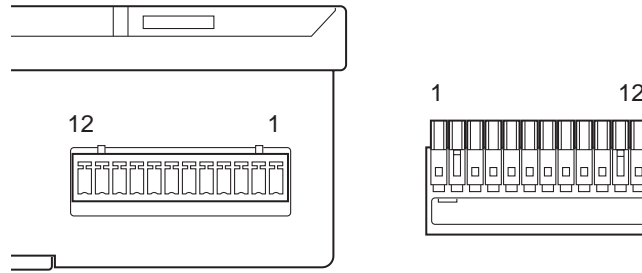

Pin number	Terminal name	I/O	Function
1	12-24V	—	Connects to the power supply. When you are using the lighting output, provide a 24 VDC power supply.
2	0V	—	Connects to the 0 V side (GND) of the power supply.
3	OK1	Output	Turns on when head 1 receives an OK judgment.
4	NG1	Output	Turns on when head 1 receives an NG judgment.
5	T11	Input	Receives the head 1 capture timing and other types of input.*
6	OK2	Output	Turns on when head 2 receives an OK judgment.
7	NG2	Output	Turns on when head 2 receives an NG judgment.
8	T12	Input	Receives the head 2 capture timing and other types of input.*
9	OK3	Output	Turns on when head 3 receives an OK judgment.
10	NG3	Output	Turns on when head 3 receives an NG judgment.
11	T13	Input	Receives the head 3 capture timing and other types of input.*
12	0V	—	This pin is connected internally to pin 2.

\* For details on the signals that can be received, see "6-6-1 Input Settings" (page 6-47).

Available wiring range

Single wire:  $\varnothing 0.4$  mm to  $\varnothing 1.2$  mm (26 AWG to 16 AWG)

Twisted wire:  $0.2$  mm<sup>2</sup> to  $1.25$  mm<sup>2</sup> (24 AWG to 16 AWG), wire diameter: 0.18 mm or more

## ● Expansion I/O connector (50-pin)

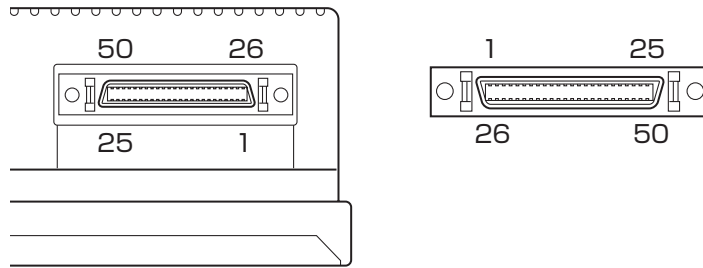

Pin number	Terminal name	Wire color*	Dot color*	Number of dots*	I/O	Function
1	OK1	Orange	Black	1	Output	Turns on when head 1 receives an OK judgment. (Same function as pin 3 of the terminal block.)
2	NG1	Gray	Black	1	Output	Turns on when head 1 receives an NG judgment. (Same function as pin 4 of the terminal block.)
3	T11	White	Black	1	Input	Receives head 1 capture timing and other types of input. (Same function as pin 5 of the terminal block.) *When using the barcode link function, the verification result and other similar values can be set to this terminal.
4	OK2	Yellow	Black	1	Output	Turns on when head 2 receives an OK judgment. (Same function as pin 6 of the terminal block.) *When using the barcode link function, the verification result and other similar values can be set to this terminal.
5	NG2	Pink	Black	1	Output	Turns on when head 2 receives an NG judgment. (Same function as pin 7 of the terminal block.)
6	T12	Orange	Black	2	Input	Receives head 2 capture timing, external teaching input, and other types of input. (Same function as pin 8 of the terminal block.) *When using the barcode link function, the verification result and other similar values can be set to this terminal.
7	OK3	Gray	Black	2	Output	Turns on when head 3 receives an OK judgment. (Same function as pin 9 of the terminal block.) *When using the barcode link function, the verification result and other similar values can be set to this terminal.
8	NG3	White	Black	2	Output	Turns on when head 3 receives an NG judgment. (Same function as pin 10 of the terminal block.)
9	T13	Yellow	Black	2	Input	Receives head 3 capture timing, external teaching input, and other types of input. (Same function as pin 11 of the terminal block.) *When using the barcode link function, the verification result and other similar values can be set to this terminal.
10	GND1	Pink	Black	2	—	Common terminal (connected internally to the 0 V terminal) for NPN input and PNP output. *When using the barcode link function, the verification result and other similar values can be set to this terminal.
11	AV1	Orange	Black	3	—	Used for NTSC/PAL video output (signal).
12	AI1	Gray	Black	3	—	Used for NTSC/PAL video output (GND).
13	AV2	White	Black	3	Reserved	Do not connect anything to these terminals.
14	AI2	Yellow	Black	3		
15	GND2	Pink	Black	3	—	Common terminal (connected internally to the 0 V terminal) for NPN input and PNP output.

Pin number	Terminal name	Wire color*	Dot color*	Number of dots*	I/O	Function
16	EX1	Orange	Black	4	Input	Used for the input of bank switching, external teaching, and forced image capturing. Select the input terminal numbers and the number of terminals used depending on the head settings.
17	EX2	Gray	Black	4		
18	EX3	White	Black	4		
19	EX4	Yellow	Black	4		
20	EX5	Pink	Black	4		
21	EX6	Orange	Black	Continuous		
22	EX7	Gray	Black	Continuous		
23	EX8	White	Black	Continuous		
24	EX9	Yellow	Black	Continuous		
25	EX10	Pink	Black	Continuous		
26	EY1	Orange	Red	1	Output	Used for the output of values such as the ready output, the coordinates, and the judgment results for each window. Select the output terminal numbers and the number of terminals used depending on the head settings.
27	EY2	Gray	Red	1		
28	EY3	White	Red	1		
29	EY4	Yellow	Red	1		
30	EY5	Pink	Red	1		
31	EY6	Orange	Red	2		
32	EY7	Gray	Red	2		
33	EY8	White	Red	2		
34	EY9	Yellow	Red	2		
35	EY10	Pink	Red	2		
36	EY11	Orange	Red	3		
37	EY12	Gray	Red	3		
38	EY13	White	Red	3		
39	EY14	Yellow	Red	3		
40	EY15	Pink	Red	3		
41	EY16	Orange	Red	4		
42	EY17	Gray	Red	4		
43	EY18	White	Red	4		
44	EY19	Yellow	Red	4		
45	EY20	Pink	Red	4		
46	GND3	Orange	Red	Continuous	—	Common terminals (connected internally to the 0 V terminal) for NPN input and PNP output.
47	GND4	Gray	Red	Continuous		
48	VCC1	White	Red	Continuous	—	Common terminals (connected internally to the 24 V terminal) for PNP input and NPN output.
49	VCC2	Yellow	Red	Continuous		
50	VCC3	Pink	Red	Continuous		

\* This is a specification of the I/O connector cable connected to the connector. For details, see "5-1-2 Select a Bank Using External Input" (page 5-8).

## ● Wiring example

- MVS-DN (NPN type)

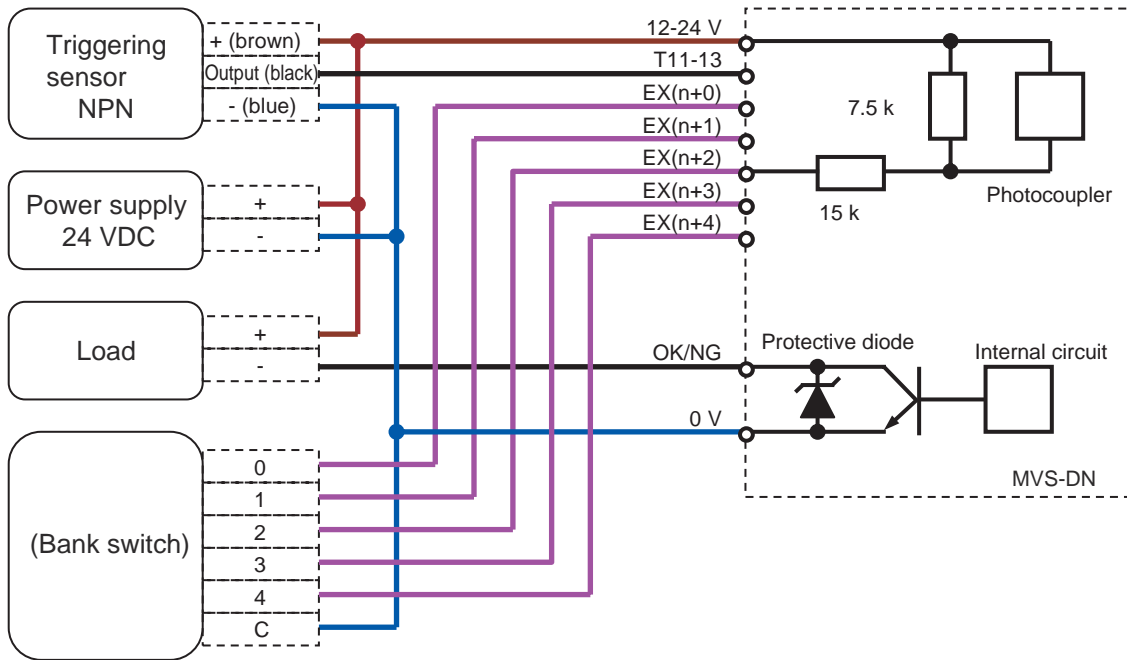

- MVS-DP (PNP type)

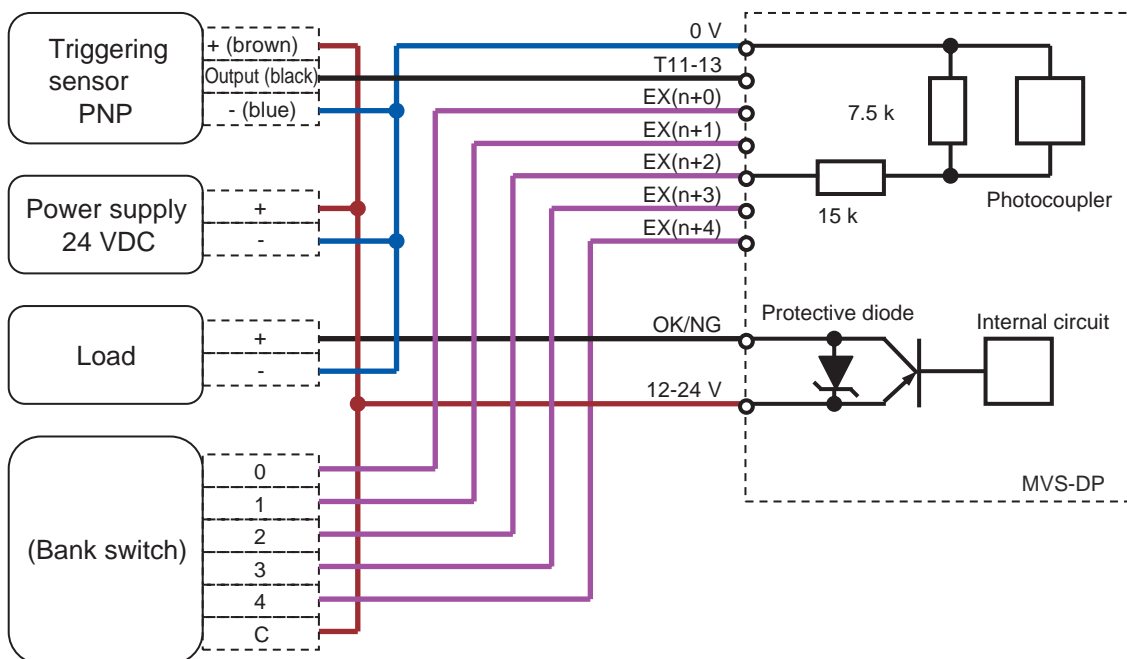

# 2-3 Installing the Camera Unit

Install the camera unit in the required location.

- 1** Line up the holes on the included mounting bracket with the positioning pins of the camera unit. Use the fixing screws to secure the mounting bracket in place.  
Tightening torque: 0.5 N•m

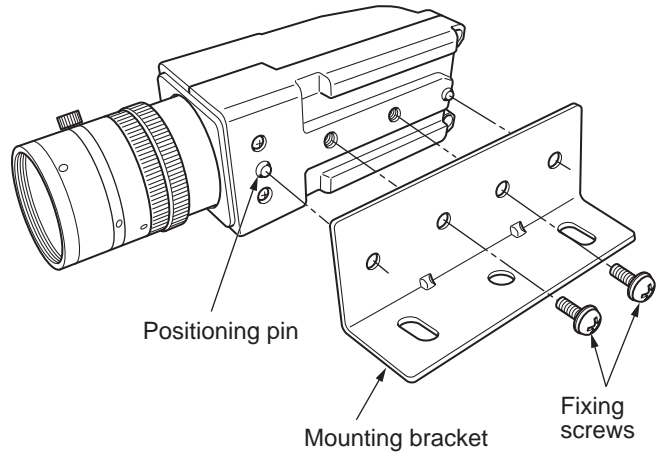

- 2** Use screws to install the camera unit in the required location.

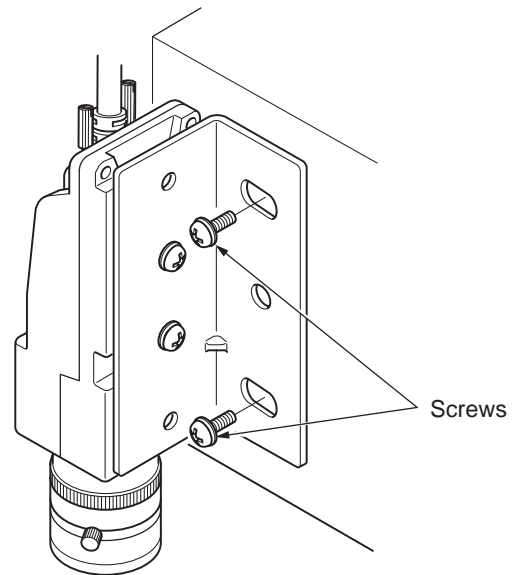

## 2-4 Installing the Controller

There are two ways to install the controller: install it in a panel or attach it to a DIN rail.

### ■ Installing the controller in a panel

- 1** Insert the controller through the front of the panel.

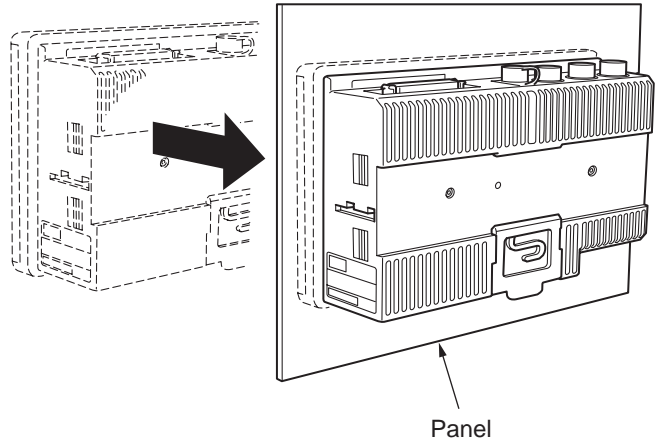

- 2** Attach the included panel mount attachments to both sides of the controller.

- 3** Press the panel mount attachments against the back of the panel to secure the controller in place.

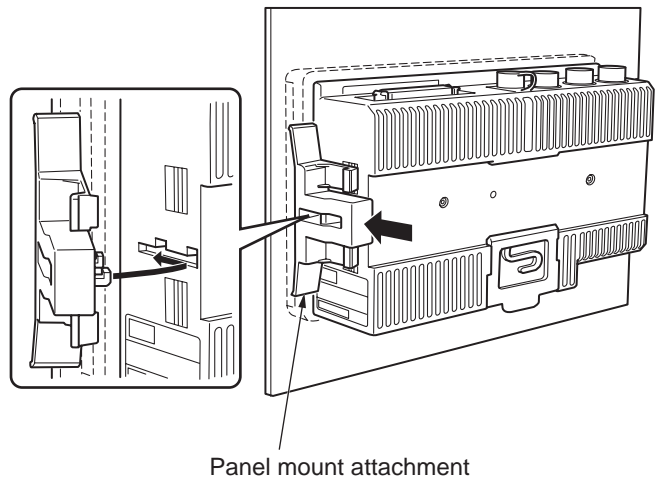

## ■ Attaching the controller to a DIN rail

- 1** Hook the tab of the top groove on the back of the controller over the top of the DIN rail.

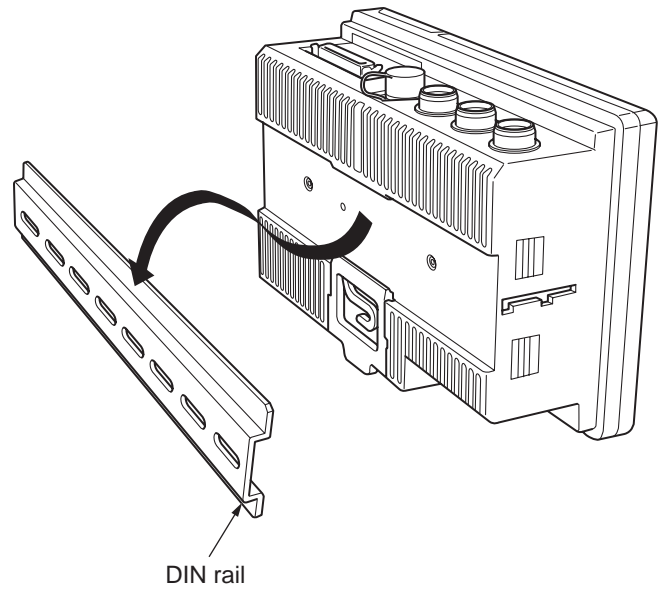

- 2** Press on the front of the controller to fit the bottom of the DIN rail into the groove on the bottom of the controller.

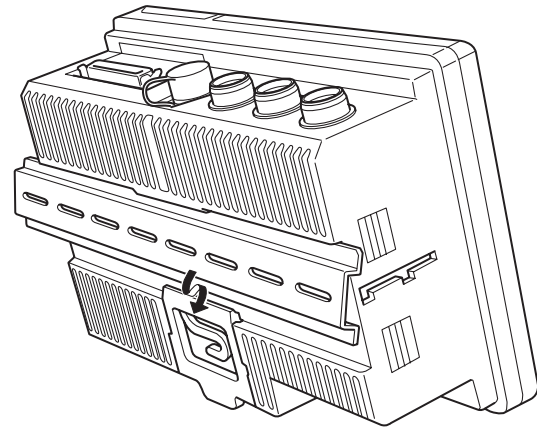

## 2-5 Connecting the Camera Unit to the Controller

Use the camera cable to connect the camera unit and the controller.

- 1 **Connect the camera cable to the controller connector on the camera unit. Turn the screw locks to lock the connector in place.**

Tightening torque: 0.2 N·m

\* When using a screwdriver or a similar tool to tighten the screw locks, keep the above tightening torque in mind.

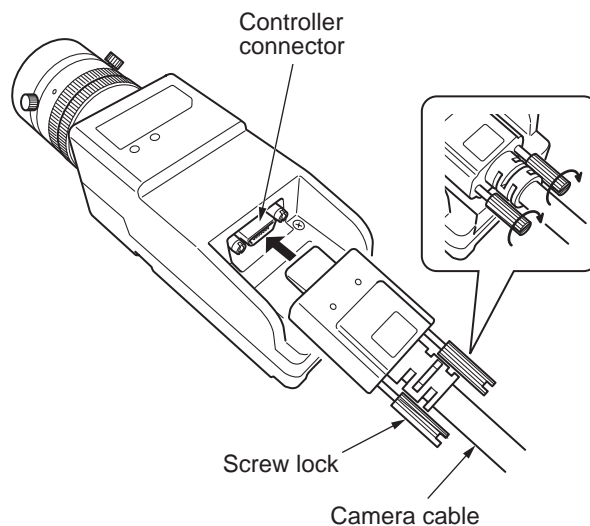

- 2 **Align the fitting guide on the camera unit connector of the controller with the groove on the connector of the camera cable. Insert the cable connector and turn the lock ring to lock the cable connector in place.**

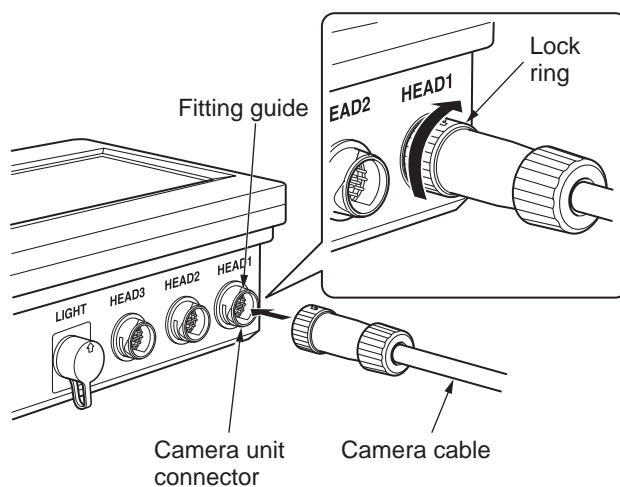

### MEMO

The minimum bend radius of the camera cable is 65 mm.

During installation, wire the devices in a manner that guarantees the minimum bend radius.

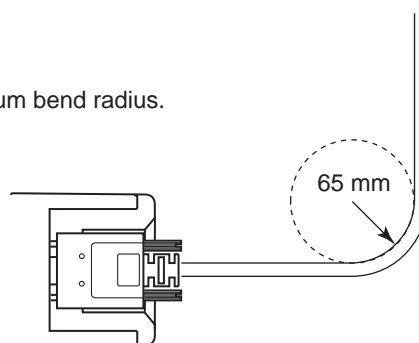

# 2-6 Connecting the LED Light

Use the LED light cable to connect the LED light to the controller.

- 1** Connect the LED light to the LED light cable.  
You can connect up to 3 LED lights (24 W total).

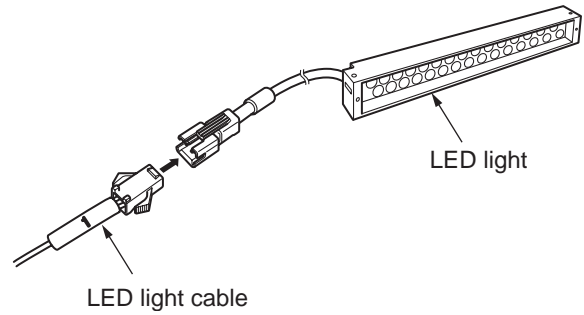

- 2** Connect the LED light cable to the LED light connector on the controller.

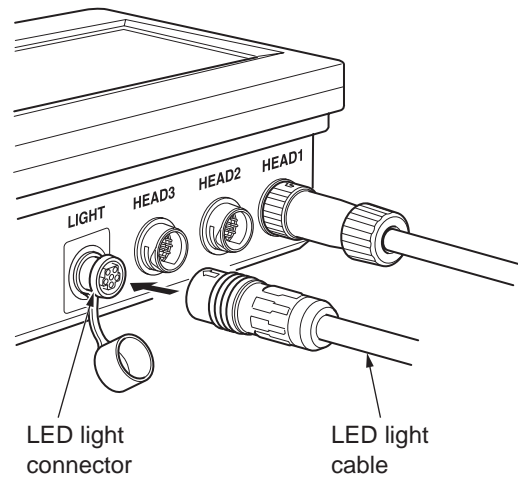

## 2-7 Attaching the Terminal Block

Connect the power supply to the terminal block (pins 1 & 2). Attach the terminal block to the controller.

- 1** While pressing the terminal block pin buttons, connect the positive wire of the DC power supply to pin 1 and the negative wire of the DC power supply to pin 2.

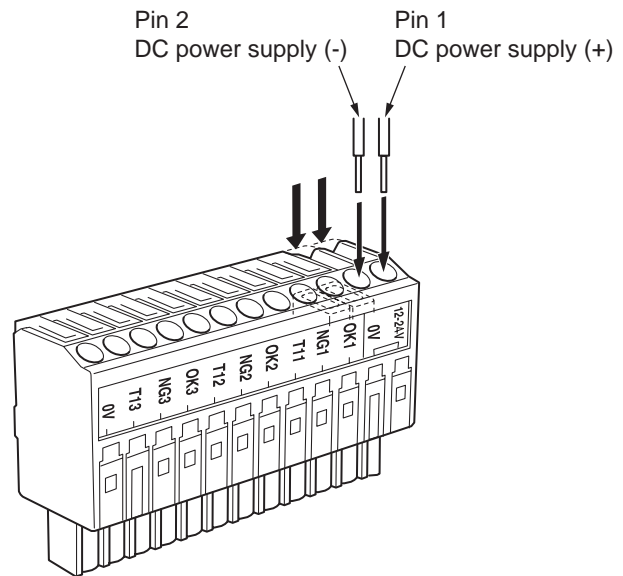

- 2** Attach the terminal block to the controller.

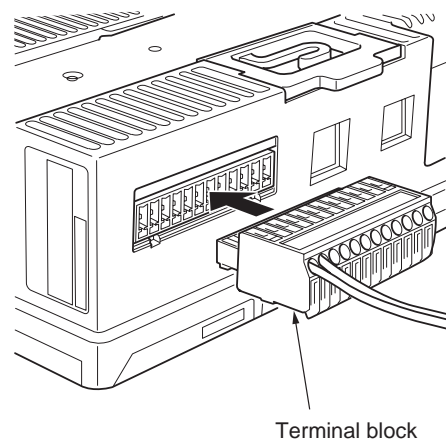

### MEMO

To connect to an external device and perform operations such as judgment output and teaching input, connect the signal wires to the appropriate terminals. For details, see "8-3 I/O Specifications" (page 8-40).

## 2-8 Selecting the Lens and Extension Ring

### Ring

Select the appropriate lens and Extension ring to match the operating environment such as the character size and the camera unit's distance from the target.

Use the following information as a reference when making a selection.

#### (1) Determining the field of view

First, determine the field of view (FOV) to match the range over which characters will be read and the size of characters.

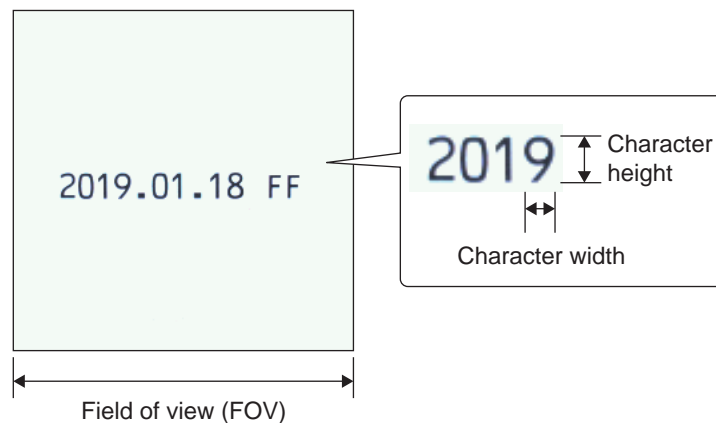

The minimum character width and height that can be read are shown below.

Field of view	30 mm	50 mm	100 mm	200 mm
Minimum character width	0.3 mm	0.9 mm	1.5 mm	3.0 mm
Minimum character height	0.6 mm	1.8 mm	3.0 mm	6.0 mm

\*There will be differences due to the font that is used.

If the character height is smaller than the minimum character height, the characters cannot be read.

A schematic diagram including the field of view (FOV), working distance (WD), and extension ring is shown below.

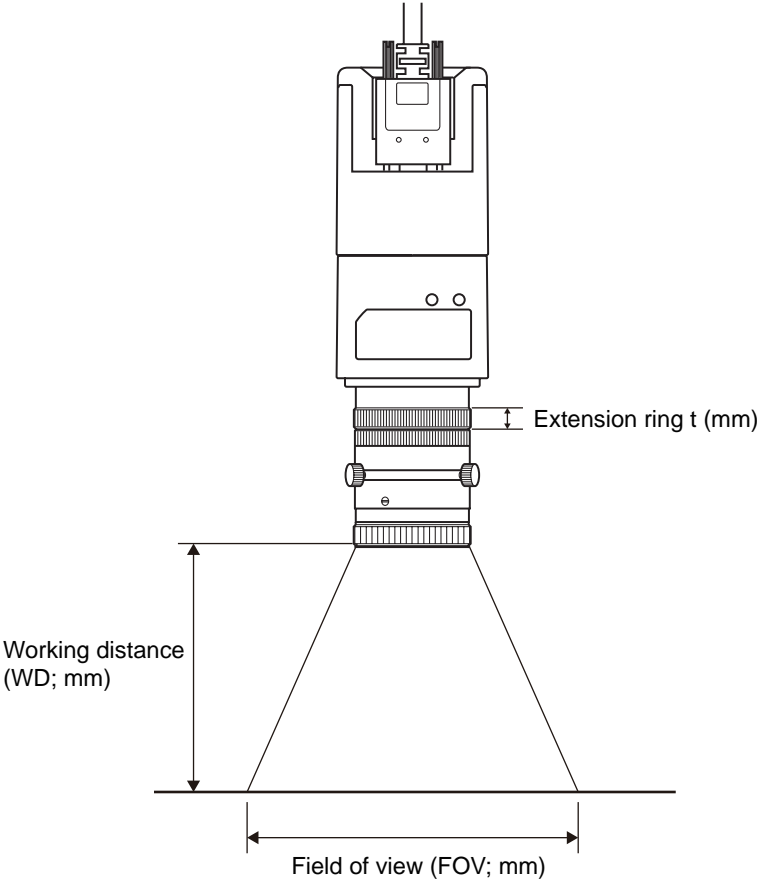

**(2) Selecting the lens and extension ring**

After you determine the field of view, select the lens and extension ring from the following optics charts.

In the chart, the horizontal axis indicates the field of view (FOV), and the vertical axis indicates the working distance (WD) of the camera unit.

- CCTV lens

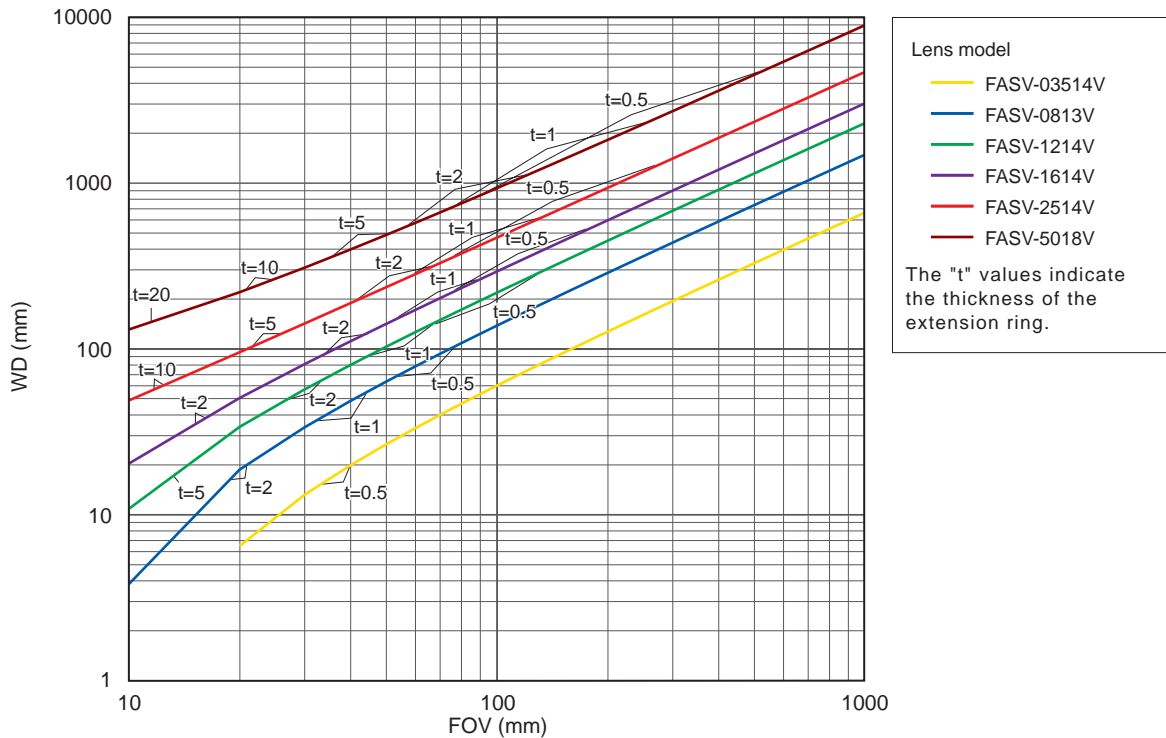

\*This optics chart contains data that corresponds to the cases in which the various lenses are attached to the camera unit.

- Macro lens with mega-pixel support

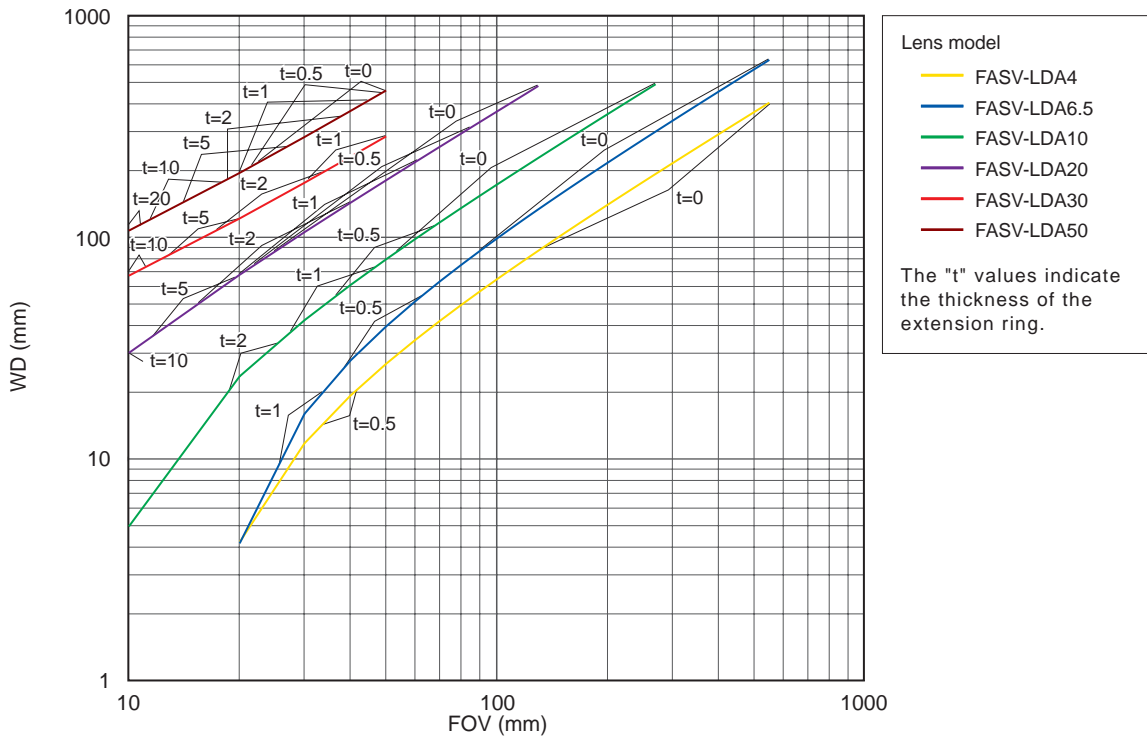

\*This optics chart contains data that corresponds to the cases in which the various lenses are attached to the camera unit.

**(Selection example)**

The field of view (FOV) is 100 mm and the working distance of the camera unit is 200 to 300 mm.

Select the lens that corresponds to the graph line at the point where the field of view (horizontal axis) value of 100 meets the working distance (vertical axis) values of 200 to 300 in the optics chart.

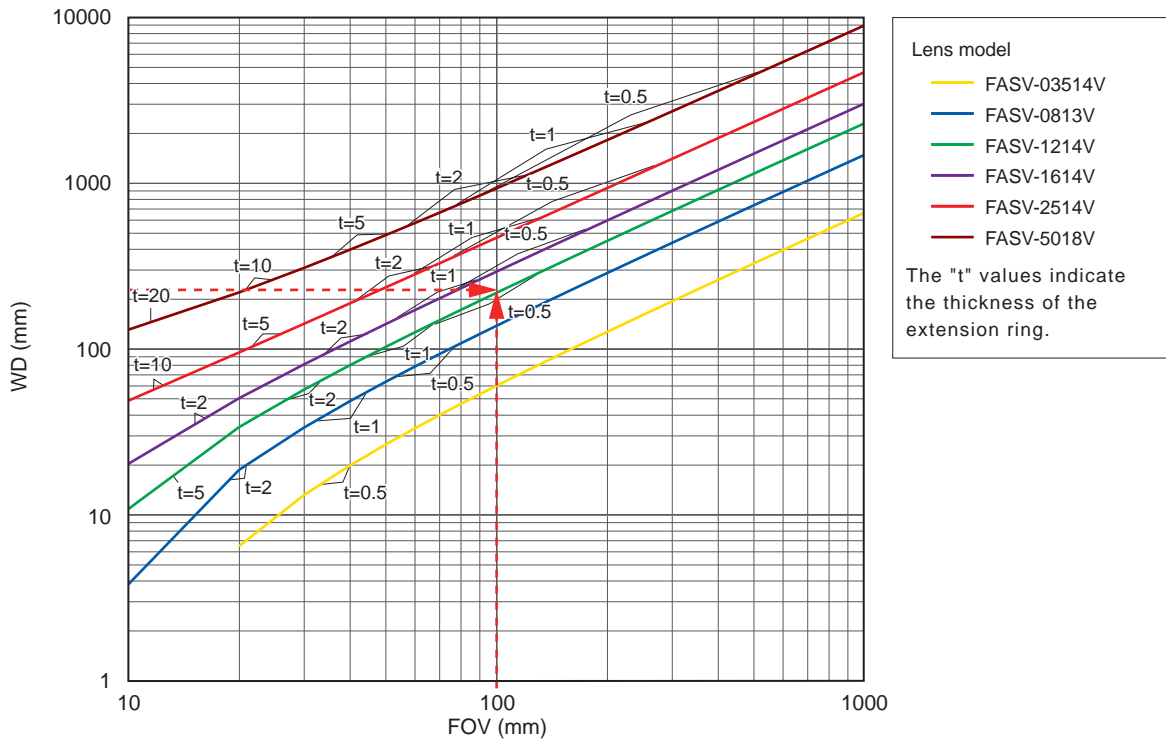

\*This optics chart contains data that corresponds to the cases in which the various lenses are attached to the camera unit.

If you use the selected lens with field of view and working distance values lower than the determined values, you will have to use an extension ring.

Select the extension ring whose thickness matches the "t" value shown in the optics charts at the intersection of the field of view and working distance values.

**Reference** .....

**About the iris**

By adjusting the iris, you can adjust the brightness and the range in which the image is in focus (the depth-of-field). See the information below, and make the required adjustments to match the line status.

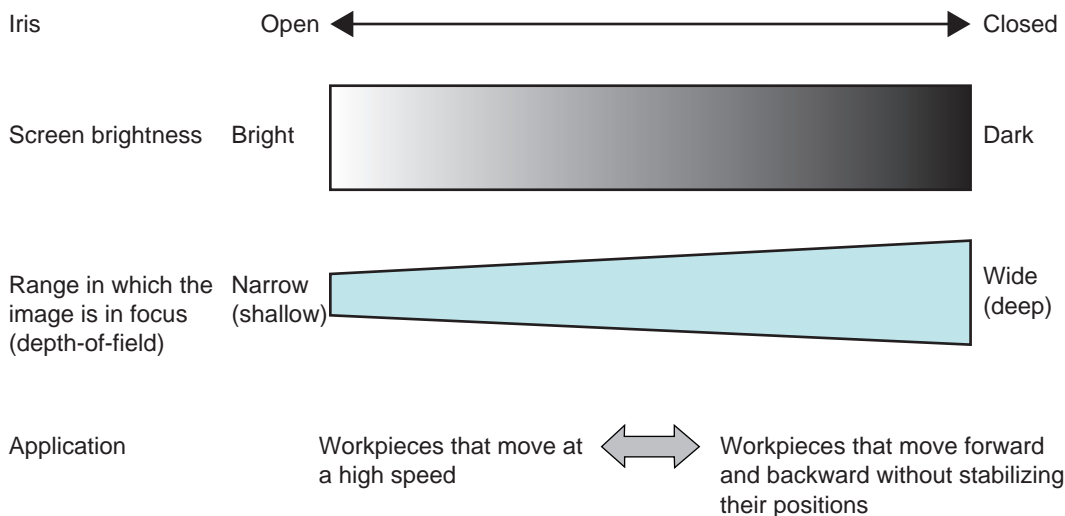

.....



---

# 3

## **Basic Operation**

This chapter explains the controller's operation screens and basic operations.

# 3-1 About the Operation Screen

When you turn on the device, the following operation screen is displayed on the controller.



Number	Name	Function
1	Camera image display	Displays images captured and processed by the camera unit.
2	Menu and details display	Displays the menu and information such as setting items and judgment results.
3	I/O status display	Displays information such as the controller's I/O status and communication status.

## MEMO

- After purchase, the first time you start the controller, a screen for setting the display language is displayed. ("7-4 Change the Display Language" (page 7-10))
- When you restart the device, the initial screen is the last screen displayed before the controller was turned off.
- If [Start-up String]—accessed by touching [Settings] and then [Etc.]—is set to "On" and you are using character string addition input, the [3-3 Edit String] screen (page 6-31) is displayed when the device starts.

## 3-1-1 Camera Image Display

The camera image display shows the judgment image, raw image, and processed image.

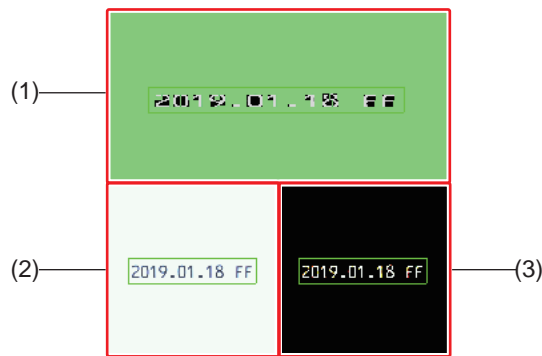

Number	Name	Function
1	Judgment image	Displays the character recognition status and the judgment result. Judgment results are displayed with the background color. When the judgment is "OK", the background is green. When the judgment is "NG", the background is red.
2	Raw image	The current captured image is displayed here.
3	Processed image	Displays the image processed based on the settings.

### ■ To zoom in on an image

Touch one of the images to display only this image on the screen.

Touch the image again to zoom in on the area around the point that you touched. Touching the image once will magnify the image by 2x. Touching the image again will magnify the image by 4x. Touch the image again to return to the three-image display.

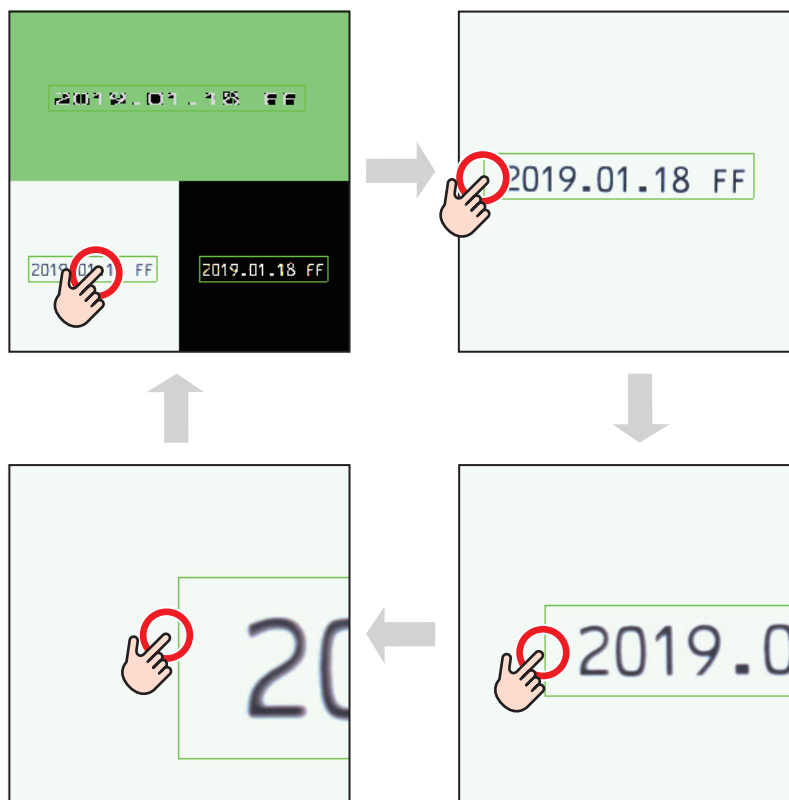

## 3-1-2 Menu and Details Display

The menu and details screen displays the menu and details such as setting items and judgment results.

### ■ Menu

Displays keys for the menu items.

Touch a key to execute the menu item.

### ● Main menu

Touch [Main Menu] on any screen to display the main menu of the device.



Key name	Function
Setup	Touch to configure the inspection settings.
Teach	Touch to re-register the image. Then, configure settings such as character cutout adjustment, format settings, and date adjustment.
Settings	Touch to switch to the [Settings] menu.
2 View	Touch to switch to a split screen showing the current inspection image and the image saved when a failure judgment occurred.
Analyze	Touch to analyze the image saved in the camera unit.
Edit String	Touch to edit the string matching characters.
System	Touch to switch to the [System] menu.
Trigger Delay	Touch to set the delay time from the detection of the trigger signal to the capture of the image.
Run View	Touch to display the operation screen.
Head number display	The number of the head whose image is currently displayed is shown here.

### ● [Settings] menu

On the main menu, touch [Settings] to display the [Settings] menu.



Touch the key for the settings that you want to configure.

### ● [System] menu

On the main menu, touch [System] to display the [System] menu.

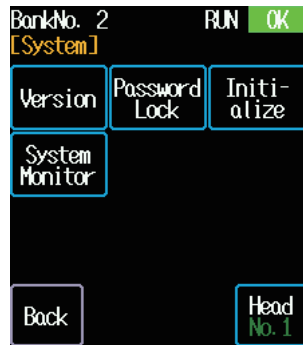

Touch the key for the system settings that you want to configure or view.

## ■ Operation screen

Each time that you touch the screen, the screen will switch to the display the following screens in order.

- (1) Judgment results
- (2) Character division and match rates
- (3) Formats 1 to 4 (when format settings exist)
- (4) Upper and lower limits on the number of characters

The contents of each screen are explained below.

### ● Items that are displayed on each screen

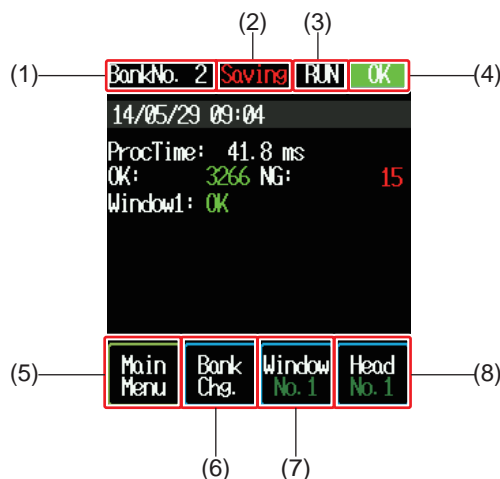

Number	Name	Details
1	Bank number	Shows the currently selected bank number. Touch [Bank Chg.] to display the [Bank Select] screen.
2	Status display	Displays "Saving" when an image is being saved. While "Saving" is displayed, you cannot save other images. *Turning the power off while "Saving" is displayed will corrupt the image being saved.
3	Operation status display	Displays "RUN" when the device is operating. Displays "STOP" when the device is stopped.
4	Judgment result display	Displays the judgment result for the captured image. Displays "OK" with a green background when the the judgment is "OK". Displays "NG" with a red background when the the judgment is "NG".
5	[Main Menu] key	Touch this key to switch to the main menu.
6	[Bank Chg.] key	Touch this key to switch to the [Bank Select] screen.
7	Inspection window number display	Displays the number of the currently displayed inspection window. When multiple inspection windows have been set, touch here to switch to the display of the inspection window with the next number.
8	Head number display	Displays the number of the head whose image is currently displayed. When multiple camera units are connected, touch here to switch the display to the camera unit with the next number. When the barcode link function is on, the device will also switch to the operation screen for barcode verification.



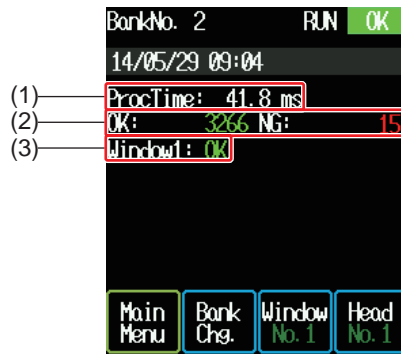

## ● Display of judgment results

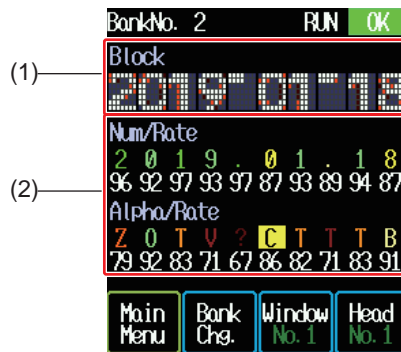

Number	Name	Details
1	ProcTime	Displays the time to perform trigger input, image capture, and judgment.
2	Pass and failure counts	Displays the total count of "OK" and "NG" judgments. The maximum display value is 99,999,999. These counts are cleared when you hold down the  key or turn the power off.
3	Inspection window judgment result	Displays the judgment result for the selected inspection window.



## ● Display of character division and match rates

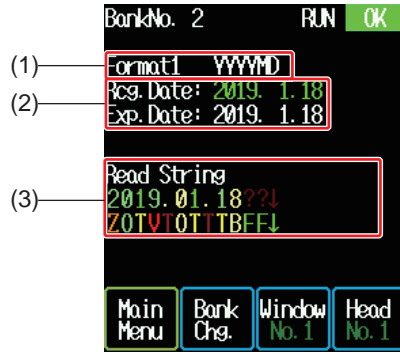

Number	Name	Details														
1	7 × 7 dot character display (block monitor)	Displays each characters read in a 7 × 7 dot grid. When there are many characters, press the  and  keys to scroll through the characters.														
2	Recognition results and match rates	Displays the reading result and the match rate with the device's built-in dictionary (00 to 99%) for each alphanumeric character. Use these match rates to determine the characters that are causing pass or failure judgments. The reading results are displayed with different colors as shown below based on the match rates. <table border="1" data-bbox="711 1688 1375 1778"> <thead> <tr> <th>Green</th> <th>Light green</th> <th>White</th> <th>Yellow</th> <th>Orange</th> <th>Red</th> <th>Brown</th> </tr> </thead> <tbody> <tr> <td>96</td> <td>92</td> <td>88</td> <td>84</td> <td>80</td> <td>76</td> <td>76 &gt;</td> </tr> </tbody> </table> Highlighted characters indicate that there is a second candidate character that also has a close match rate. For example, in the above screen, the character "T" shown in the third position from the right under [Alpha/Rate] is highlighted. When there are many characters, press the  and  keys to scroll through the characters.	Green	Light green	White	Yellow	Orange	Red	Brown	96	92	88	84	80	76	76 >
Green	Light green	White	Yellow	Orange	Red	Brown										
96	92	88	84	80	76	76 >										

● Display of formats 1 to 4 (when formats have been set)



Number	Name	Details
1	Format display	Displays the style of the set format. When multiple formats have been set, touch the screen to switch between formats.
2	Rcg. Date or character Exp. Date or character	Displays the date or characters read by the device and the date or characters used for judgment. Upper row: The read details Lower row: The details that received an "OK" judgment
3	Read Strings	Displays a list of the read character strings. Read characters are colored based on the "Recognition results and match rates" on the previous page. When there are many characters, press the  and  keys to scroll through the characters.

● Display of upper and lower limits on the number of characters

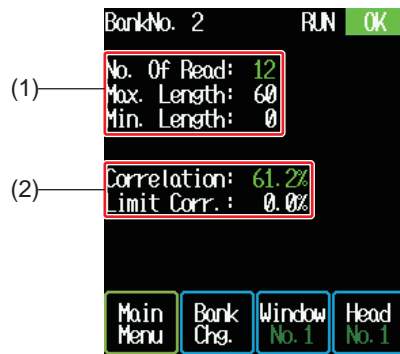

Number	Name	Details
1	No. Of Read Max. Length Min. Length	Displays the number of read characters and the upper and lower limits for "OK" judgment.
2	Correlation Limit Corr.	Displays the value of correlation with the registered pattern and the correlation lower limit. These values only display after you have perform a search (Page 6-60).

## 3-1-3 I/O Status Display

The I/O status display shows the head connection status and the communication status for monitoring.

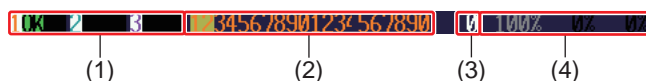

Number	Name	Function
1	Head output status monitor	Displays "OK" when the output of heads 1 to 3 are normal and "NG" when there are problems.
2	Expansion output terminal status monitor (only displayed when the I/O connector cable is connected)	Displays the status of the expansion output terminals (EY1 to EY20) of the expansion I/O connector. The leftmost number "0" represents EY1, and the rightmost number "0" represents EY20. Displays the output terminals with the following colors. Orange: Output from head 1 Blue: Output from head 2 Purple: Output from head 3 Red: Output from multiple heads
3	Serial communication status	Displays "0" during serial communication.
4	Head communication status monitor	Displays the communication success rates for each head from left to right starting with head 1 then head 2 then head 3. Displays a value between 90 and 100% (depending on the communication status) when the communication status is normal. A displayed value of less than 90% may be caused by a device error or interference from noise caused by other devices or wires. In this case, contact Optex FA.

## 3-2 Basic Operations

This section explains basic operations.

### 3-2-1 Operations Using the Touch Screen

You can perform the following operations using the touch screen.

The main operations in the image display area are shown below.

#### ■ Executing touch key functions

The items displayed as buttons are referred to as "touch keys."

When you touch a key, the color of the key changes and the key operation is performed.

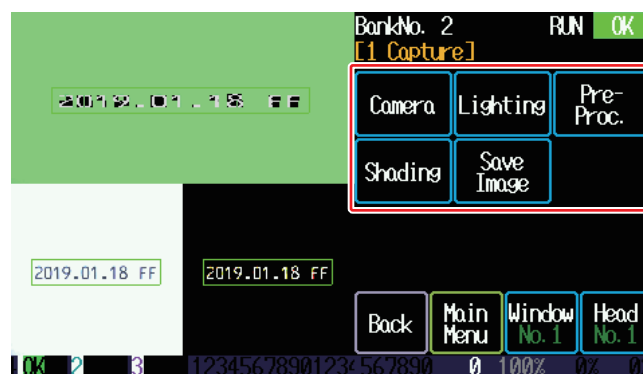

#### ■ Specifying setting values

When you touch a setting displayed on the screen, the cursor moves to the setting, allowing you to change the value.



## Switching the displayed information

Each time that you touch the screen, the device switches the displayed information.

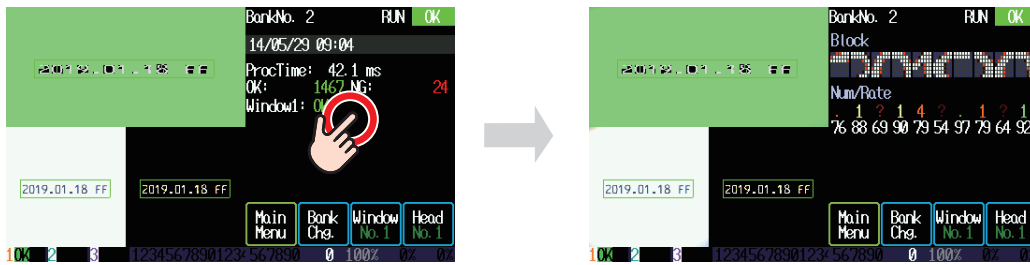

## Specifying points when setting the range

When configuring inspection window settings or other settings, touch the point on the screen that you want to specify.



## 3-2-2 Numeric Keypad Operations



Depending on the operation, keys on the numeric keypad that can be used are lit in green.



The main numeric keypad operations are shown below.

### ■ Moving the cursor

Use the , , , and  keys to move the cursor.

For example, press the  and  keys to move the cursor to select the setting value.



## ■ Configuring and changing settings

### ● Configuring settings in edit mode

Select a setting and press the **SET** key to switch to edit mode.

Follow the procedure below to configure or change the setting.

- 1 When you press the **SET** key, the color of the selected setting value changes to red. You can now change the setting value.



- 2 Use the **↑** and **↓** keys to change a setting value.



If you press and hold down a key, the value will change more quickly.



- 3 Press the **SET** key again to confirm the setting value.





## ● Configuring settings in numeric value edit mode

When you select a setting, if the  key lights, you can press the  key to switch to numeric value edit mode. In this mode, you can directly enter numeric values for each digit. Follow the procedure below to configure or change a setting.

- 1** When you press the  key, the color of the selected setting value changes to red. You can now change the setting value.



- 2** Press a key from  to  to add the digit as the least-significant digit of the displayed value.

If the added digit causes the value to exceed the upper limit of the setting range, the upper limit value will automatically display.



Press the  key to set the value to "0."



Each time you press the  key, the value switches between "0" and "-0." You can directly edit negative values by entering values when "-0" is displayed.



---

### ●●● MEMO ●●●

Only settings that have negative minimum setting values can display or be set to negative numeric values.

---

- 3** Press the **SET** key to confirm the setting value.



### MEMO

- Press the **EXIT** key during edit mode or numeric value edit mode to return the setting value to its original value and exit edit mode.
- Press the **?** key to display help information on the screen.

### Setting example

Changing a setting's default value from "16" to "50"

- 1** Select the setting.



- 2** Press the **NUM/DEL** key.  
You can now change the setting value.



- 3** Press the **NUM/DEL** key again.  
The setting value changes to "0."



**4** Press the  key and then the  key.



**5** Press the  key.  
The setting value changes to "50."



---

# 4

## Setup

This chapter explains how to set up the device.

# 4-1 Setup Flowchart

This device is equipped with a setup menu and a wizard that can be used to easily configure basic settings.

The procedure for configuring the settings through the setup menu is shown below.

The procedure differs depending on whether a colored pattern is present in the background of the inspection target. See the corresponding section listed below.

- If the background of the inspection target does not have color or a colored pattern → "4-2 Standard Setup" (page 4-3)
- If the background of the inspection target has color or a colored pattern → "4-3 Setup for Color Extraction" (page 4-20)

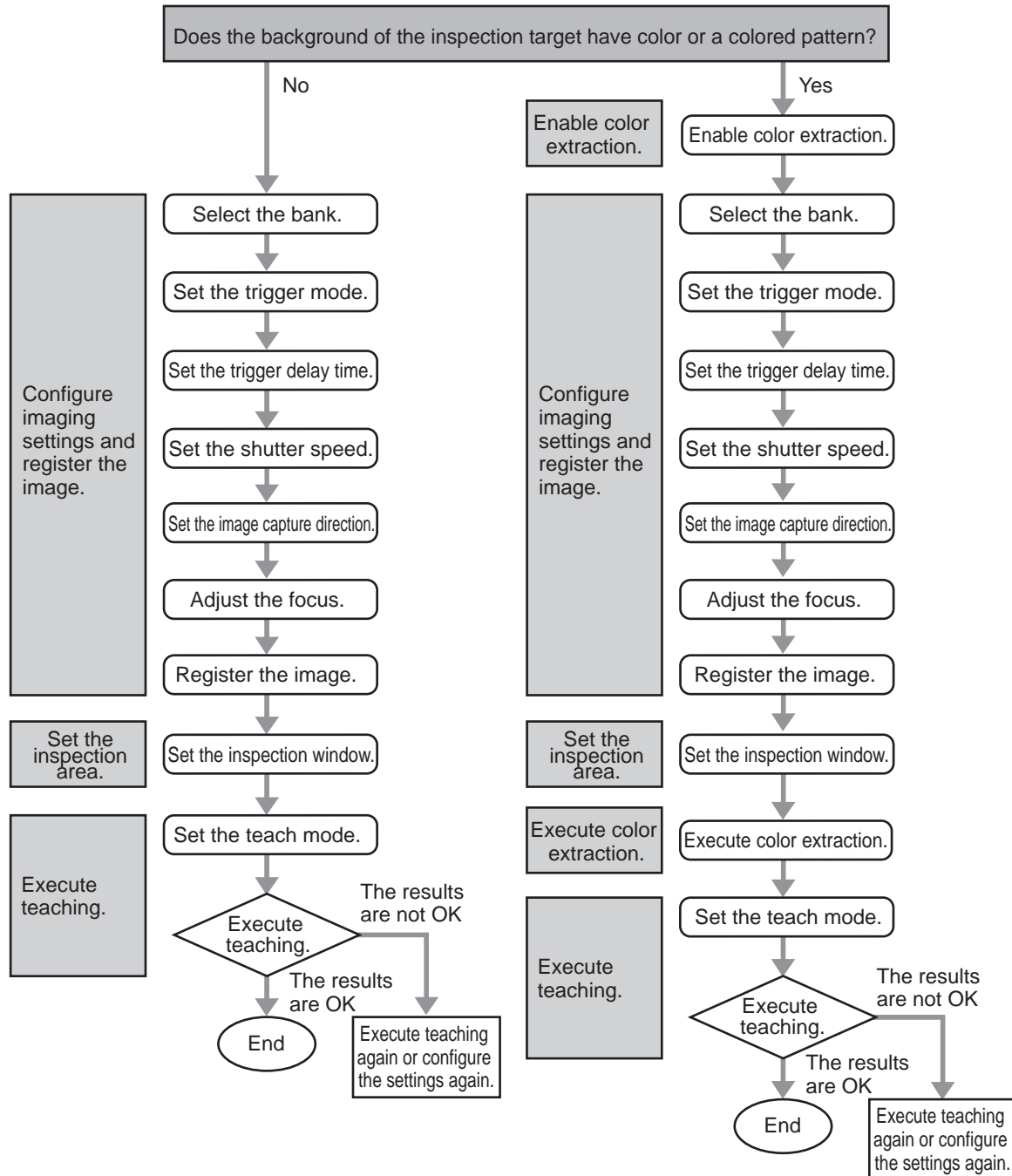

## MEMO

- During setup, the device stops operating.
- When you are using an encoder to control the timing with which the camera captures images, after you finish setup, set "Sync Pulse Port" from the main menu. ("6-6-1 Input Settings" (page 6-47))

# 4-2 Standard Setup

If the background of the inspection target does not have color or a colored pattern, perform the standard setup explained below.

## 4-2-1 Starting the Setup Menu

Start the setup menu.

- 1 Turn on the device.**  
The operation screen displays.



- 2 Touch [Main Menu].**

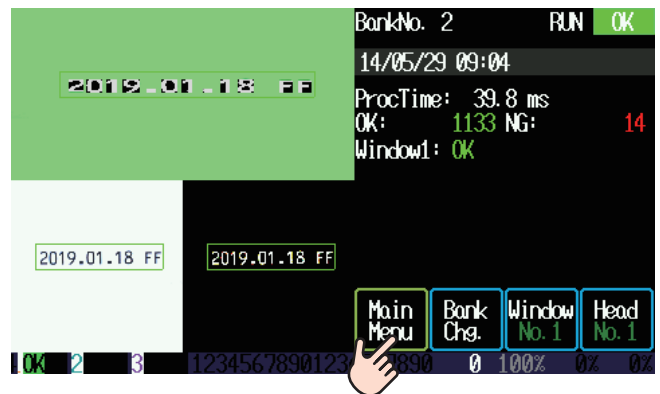

- 3 Touch [Setup].**



- 4 Touch [OK].  
The device stops operating and the setup menu displays.

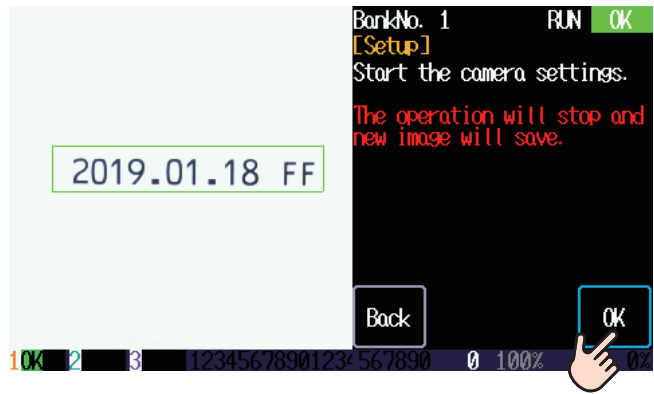

### MEMO

To return to the previous screen, touch [Back].

## 4-2-2 Selecting the Bank

Register the new settings to a new bank or overwrite the settings of an existing bank.

- 1 On the [Bank Select] screen, touch the screen or press the and keys to select the bank that you want to set.  
To register the new settings to a new bank, select an empty bank (displayed as a string of dashes). To register the new settings to an existing bank, select the bank that you want to overwrite.



### MEMO

- To select a bank that is not displayed on the screen, swipe up or down on the screen (with your finger touching the screen in a swiping motion) to move through the pages.
- When you register the new settings to a new bank, the bank name is automatically set to a time stamp (year/month/day hour:minute).
- You can assign any bank name and comment to a bank after it has been set. For details on how to set bank comments, see "■ Add a comment to a bank" (page 5-5).

- 2 Touch [OK].

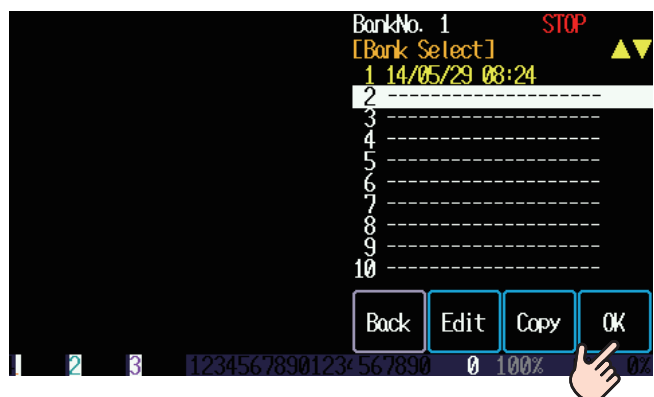

### MEMO

You can also copy the contents of an existing bank to a different bank. For details on how to copy banks, see "■ Copy a bank" (page 5-3).

## 4-2-3 Configuring Settings for Capturing Images

Configure the settings for capturing images.

### ■ Configuring the trigger mode setting

Set the image capture timing.

#### Reference

##### What is trigger mode?

Trigger mode is used in systems where a trigger sensor or similar device is connected to the trigger mode terminals (T11 to T13) of the terminal block or the expansion I/O connector and trigger signals are being detected. When the image target object arrives in front of the camera unit, the controller receives a trigger signal and the image is captured.



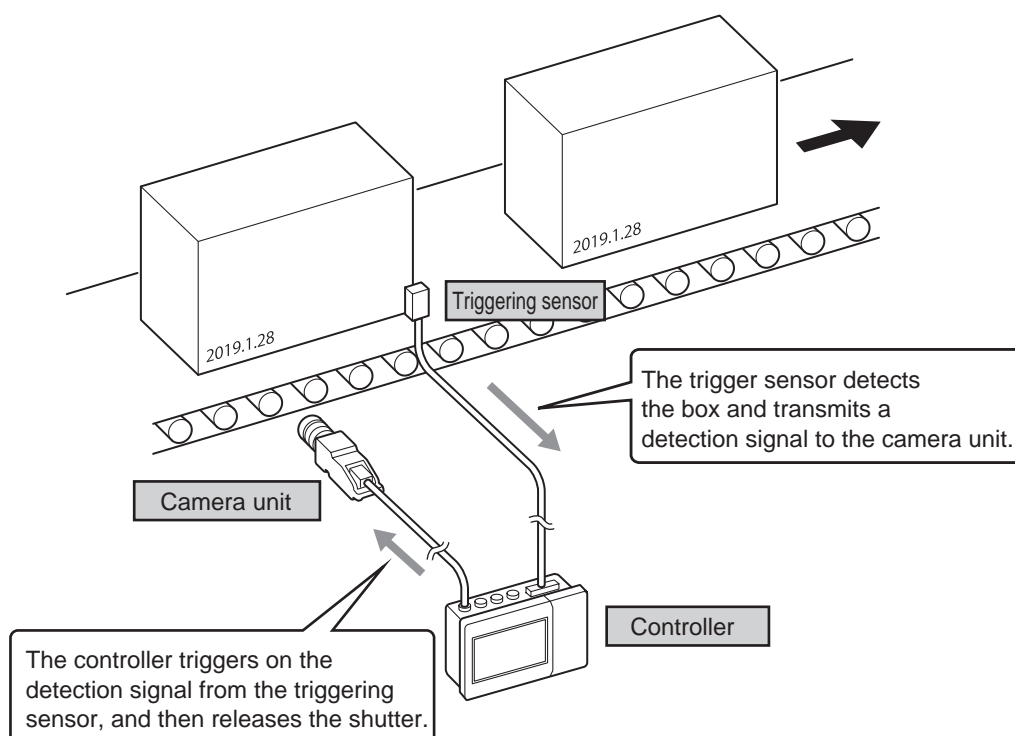

Be sure to set the timing of the trigger mode signal to capture the image.

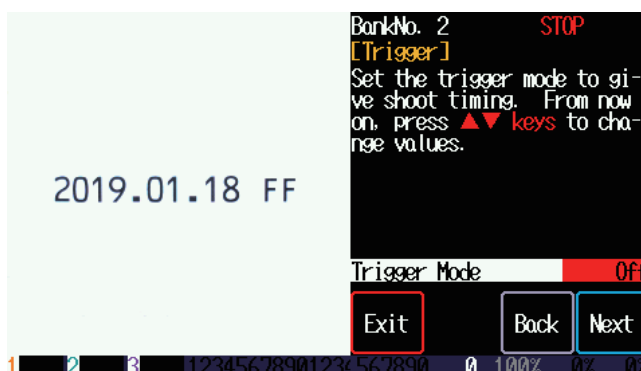

- 1 On the [Trigger] screen, press the and keys to set the trigger mode.



You can select one of the following values.

Setting	Details
Off	Regardless of the status of the trigger mode terminal, images will be captured automatically.
Rise	Images will be captured when the trigger mode terminal switches from OFF to ON. 
High	While the trigger mode terminal is ON, the device will repeat the following procedure: capture the image, perform an inspection and then perform the judgment. 
Fall	Images will be captured when the trigger mode terminal switches from ON to OFF. 
Low	While the trigger mode terminal is OFF, the device will repeat the following procedure: capture the image, perform an inspection and then perform the judgment. 

## 2 Touch [Next].

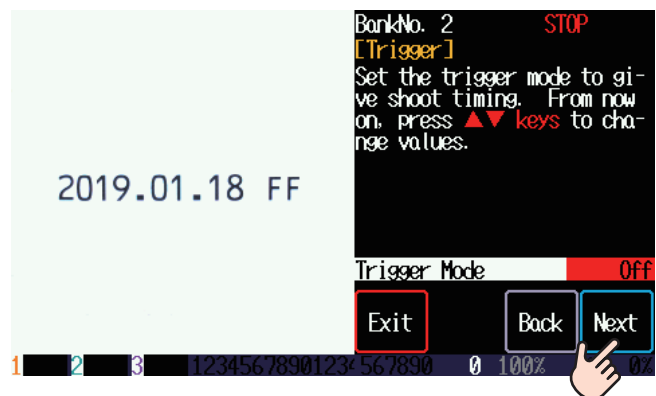

## ■ Configuring the trigger delay time setting

If required, set the delay time from the detection of the trigger signal to the capture of the image.

### Reference

#### What is the trigger delay time?

When you use the trigger mode to capture images, you may not be able to set the correct timing due to differences between the time the trigger mode signal is received and the camera's installation position. This can arise from the installation space and the previous and subsequent processes.

The "trigger delay time" enables you to insert a delay before the camera captures an image.

You can set the trigger delay time to a value up to 6000 ms (6 seconds).

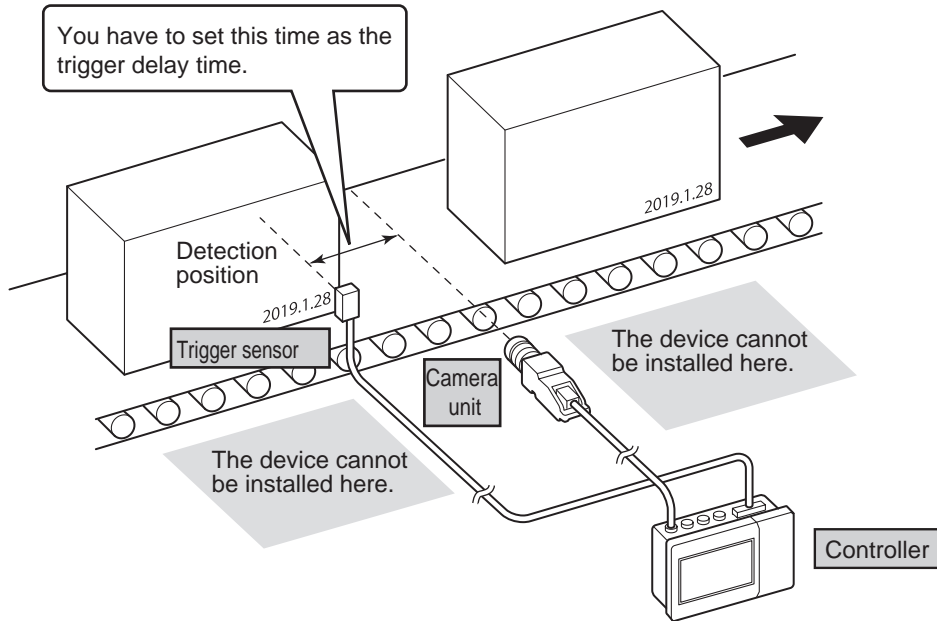

- 1 On the [Trigger Delay] screen, press the **▼2**, **▲8**, **3**, and **9** keys to set the trigger delay time in units of 0.1 ms (100 μs).

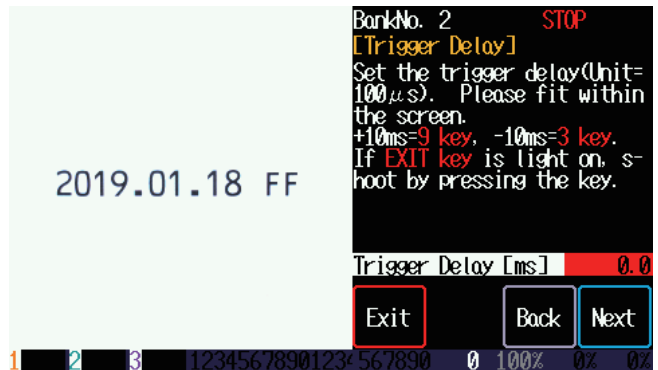

### MEMO

- Press the **3** and **9** keys to increase or decrease the value by 10 ms. Press the **▼2** and **▲8** keys to increase or decrease the value by 0.1 ms.
- You can press the **EXIT** key to capture the current image.

## 2 Touch [Next].

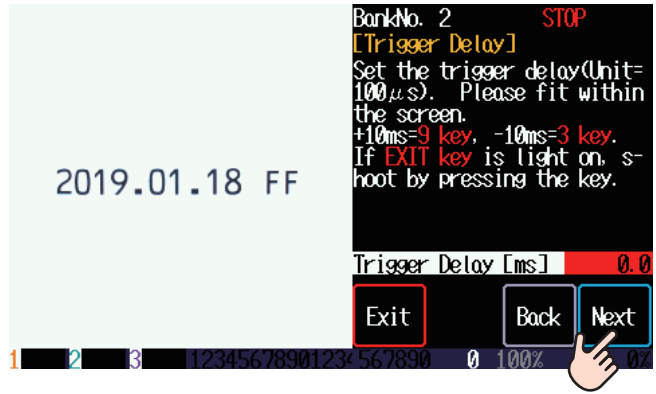



## ■ Setting the shutter speed

Set the camera shutter speed.

The faster the shutter speed (the smaller the setting value), the easier it is for the device to track fast moving inspection target objects. However, the captured images may be dark.

In this case, you can adjust the brightness of the LED light or the lens iris to improve the image.

- 1 On the [Shutter] screen, press the  and  keys to set the shutter speed (fractions of a second).

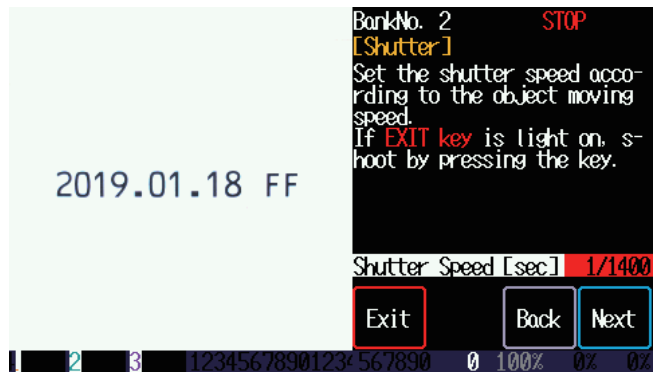

You can select one of the following values.

The larger the denominator, the faster the shutter speed.

Setting
1/7, 1/10, 1/15, 1/21, 1/30, 1/42, 1/60, 1/85, 1/120, 1/170, 1/240, 1/350, 1/500, 1/700, 1/1000, 1/1400, 1/2000, 1/2800, 1/5500, 1/7000, 1/9200, 1/13800, 1/27500 (of a second)

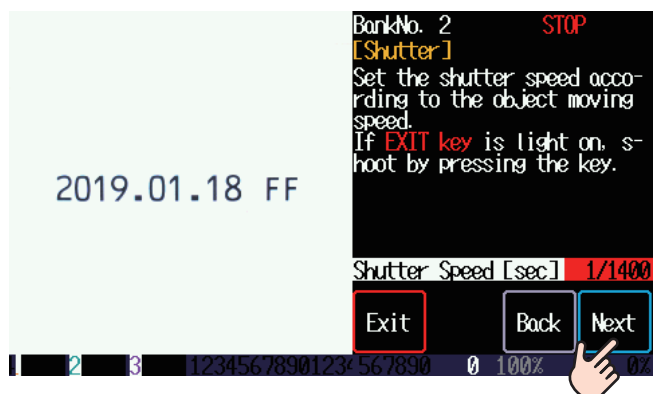

## 2 Touch [Next].







## ■ Setting the image capture direction



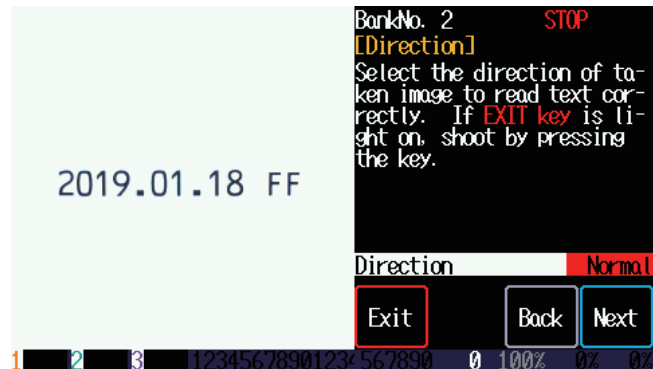

When the characters of the inspection target are not upright or are mirrored, you can rotate or invert the captured image to orient the characters within the image so that they are at the correct angle and are facing the correct direction.

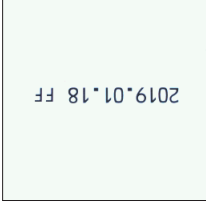
Characters are rotated in units of 90°. Use mirrored characters when characters printed on transparent packages are being captured from behind.

- 1 On the [Direction] screen, press the  and  keys to set the image capture direction.

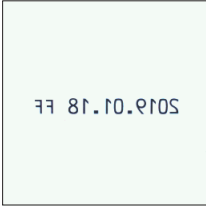

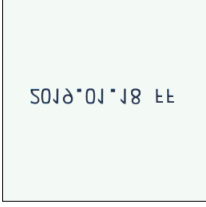
Setting	Details
Normal	The image will not be rotated or inverted. 
RTT. 90	The image will be rotated 90° to the left. 
RTT. 180	The image will be rotated 180°. 
RTT. 270	The image will be rotated 90° to the right. 

Setting	Details
MIRR.	The image will be inverted to its mirror image. 
MIRR. 90	The image will be inverted to its mirror image and rotated 90° to the left. 
MIRR. 180	The image will be inverted to its mirror image and rotated 180°. 
MIRR. 270	The image will be inverted to its mirror image and rotated 90° to the right. 

## 2 Touch [Next].



## ■ Adjusting the focus

Adjust the focus.

- 1 Turn the focus ring so that the green gauge on the [Focus] screen is at the farthest point to the right as possible. The farthest possible point to the right is the point at which the image is in focus. The white line indicates the peak position.

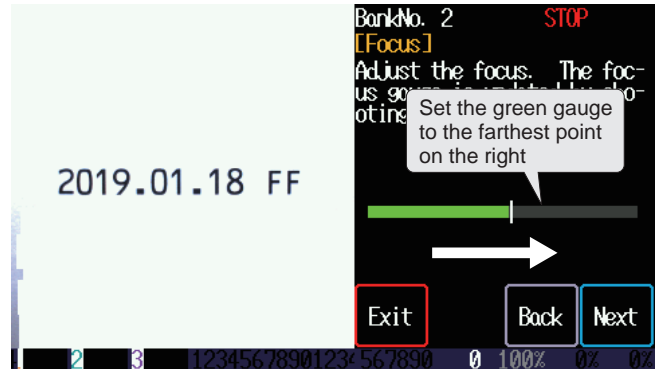

### Caution

Ensure that the inspection target is stationary so that the state of the captured image does not change. Also, do not change the lens iris.

- 2 Touch [Next].

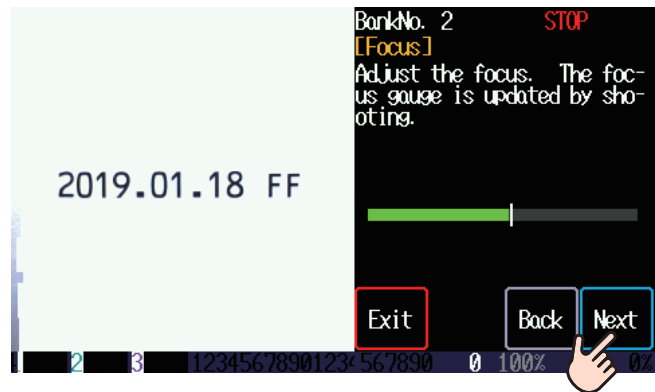

## ■ Registering the image

Register the current image to the device.

The image registered here will be the reference image used in judgments.

- 1 On the [Save Image] screen, touch [Save Image].

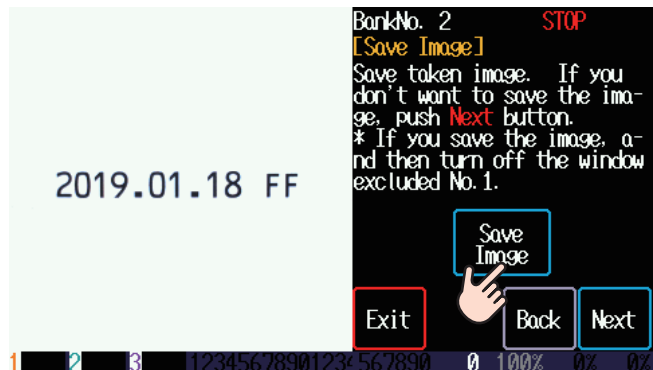

While the image is being saved, the message "Saving image..." and a progress bar are displayed.



### Caution

Never turn the power off while an image is being saved. Doing so will corrupt the image being saved.

After the data is successfully saved, the message "Saving image is completed." displays, and the image is registered to the device's memory.



## 4-2-4 Setting the Inspection Window

Before you perform inspection of printed characters, set the region of the image that will be used as the inspection target.

This area is called the "inspection window."



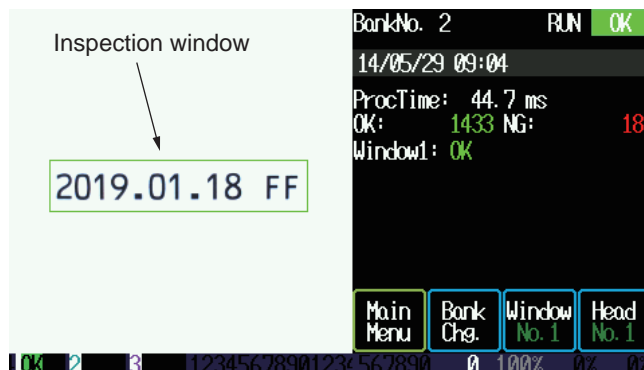

When selecting the inspection window, select just the area with the printed characters.

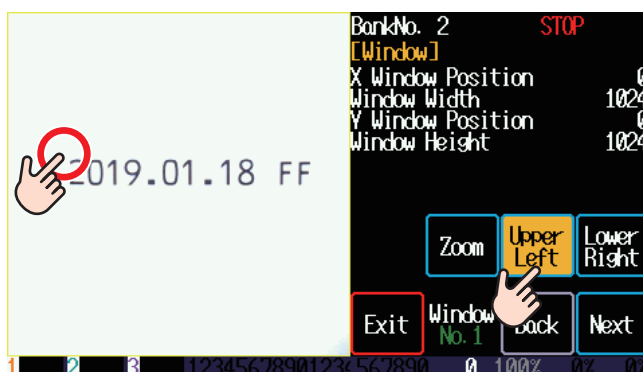

- 1 On the [Window] screen, touch [Upper Left]. Then, touch the point on the image that you want to specify as the upper-left corner of the inspection window.



The intersection of the horizontal and vertical lines is the specified point.

After you specify this point, press the  and  keys to make fine adjustments to the position in the vertical direction and the  and  keys to make fine adjustments to the position in the horizontal direction.

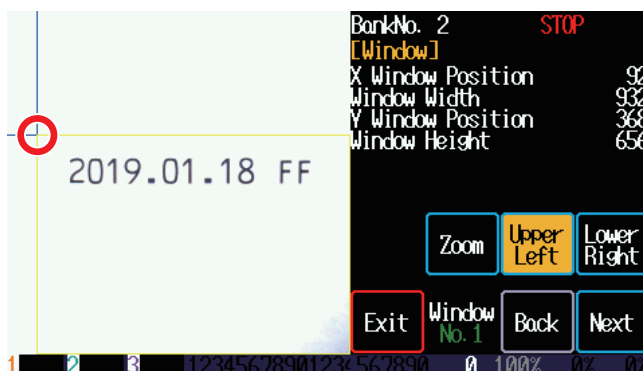

### MEMO

- Touch [Zoom], and then touch somewhere on the image to zoom in around the spot that you touched. The image displays at a magnification of 2×. Touch again to increase the magnification to 4×. Touch [Upper Left] or [Lower Right] to enable the adjustment of the region of the inspection window.

- Touch [Lower Right]. Then—with the same operations that you performed in step 1—specify the point on the image to use as the lower-right corner of the inspection window.

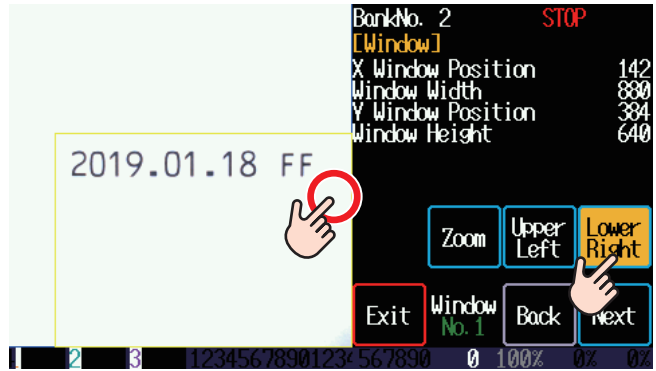

The inspection window setting is complete.

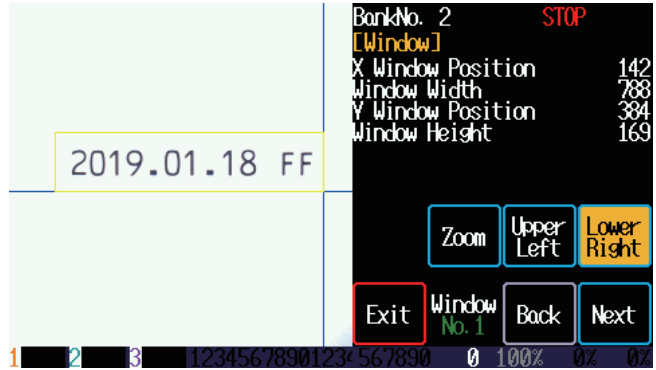

- Touch [Next].



### MEMO



You can adjust the inspection window again as one of the final setting items during setup.

Also, you can adjust the inspection window again even after setup is finished by touching [Settings] on the main menu, and then touching [Window].

("6-7 The Inspection Window" (page 6-57))

## 4-2-5 Performing Teaching

Teaching stores the characters in the inspection window on the device.

- 1 With the [Teach] screen displayed, press the  and  keys to set the teaching mode.



Select one of the following values to match the inspection details.

Setting item	Details
DateStr	Inspection of the date and character string.
Date	Inspection of the date.
String	Inspection of the character string.
No. OfStr	Inspection of a number of characters.

- 2 Touch [Next].



- 3 Touch [Teaching].

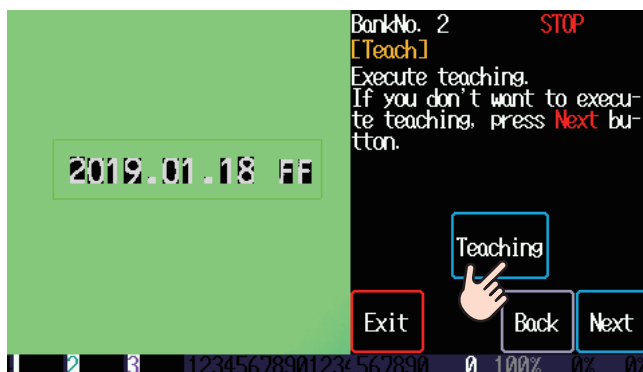

The teaching operation begins.  
 The time required for teaching to finish will vary depending on conditions such as the details of the printed characters.



When teaching is finished, the results are displayed for the different formats on the [Result] screen.



Check the results and judge whether the teaching results are OK.

**When the teaching results are OK**

Touch [Exit] to finish setup.

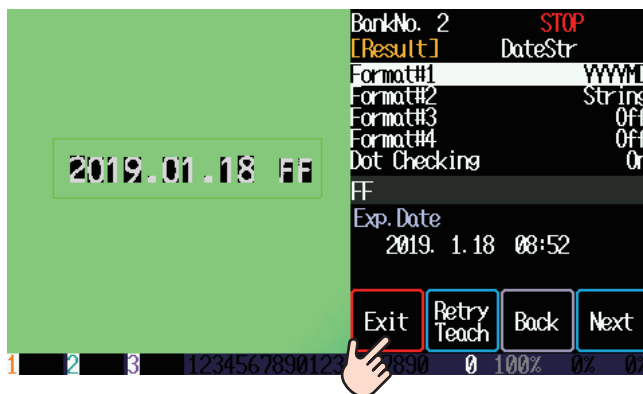

**When you want to perform teaching again**

Touch [Retry Teach].  
 The teaching operation will be performed again with the same conditions.

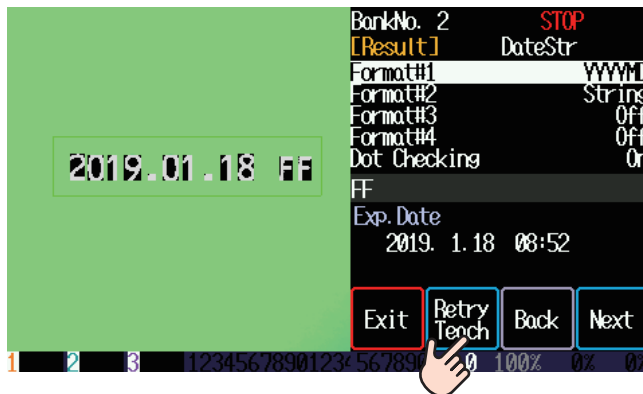

**When you want to adjust the inspection window again**

Touch [Next], and then touch [Window] on the [Select] screen to display the [Window] screen. Then, adjust the inspection window again.

When you perform "Retry Teach" on the [Result] screen after manually changing the settings, the manually set details are compared against the values automatically adjusted by the device, and those items with the higher internal score are selected for the following items on the [Extract] menu.

- Char. Width
- Char. Height
- Min. Width
- Min. Height
- Height Limit
- Rotation Correction
- Slant Offset
- Slant Correction
- X Dot Period
- Y Dot Period

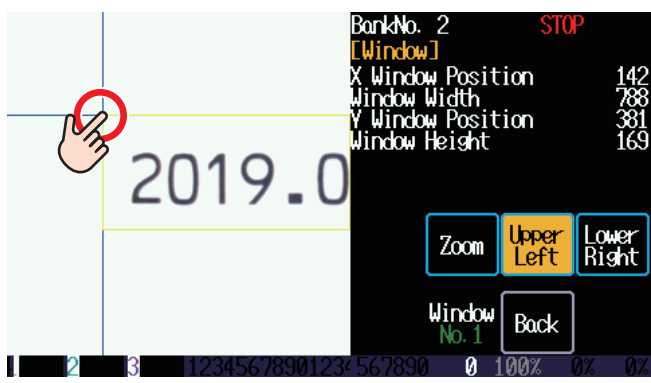
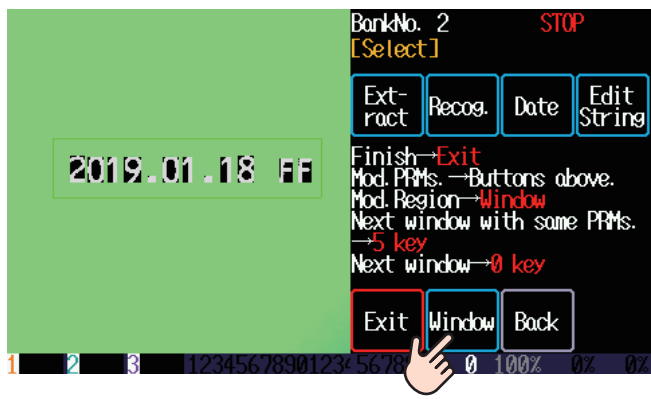
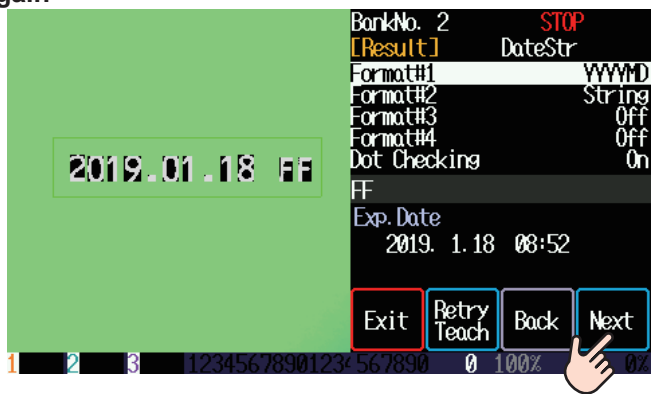

**When you want to specify multiple inspection windows**

After teaching and the various adjustments are finished, use the [Select] screen to specify the inspection windows.

Press the **5** key to copy the inspection window that you set this time and set the next inspection window. The same settings will be copied to the next inspection window.

Press the **0** key to set the next inspection window as a new inspection window.

The [Window] screen is displayed. Set the inspection window by following the procedure listed in "4-2-4 Setting the Inspection Window" (page 4-13).



## MEMO

Depending on the details of the printed characters, the format may not be correctly recognized during the teaching operation.

If the format has not been recognized correctly after the teaching operation, manually correct the format setting, and then perform the teaching operation again.

### Setting example

Printed characters including the date, the time, and characters

- (1) Date (YYYYMD)      (2) Factory symbol (String)

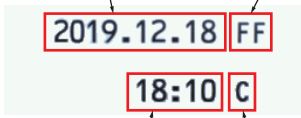

- (3) Time (HH:MM)      (4) Line symbol (String)

Status after the teaching operation is executed

(Format 3 is recognized as "String" and format 4 is recognized as "Off.")

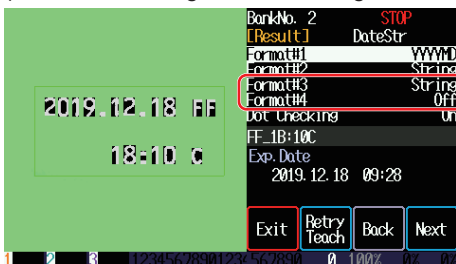

Set format 3 to "HH:MM" and format 4 to "String," and then touch [Retry Teach].

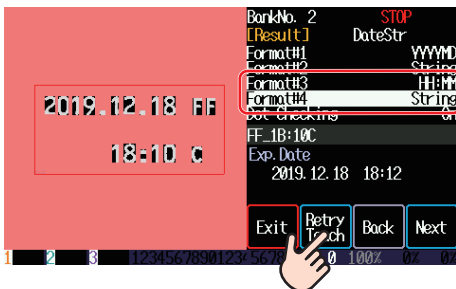

The values are reset to the correct formats.



\*The matching character string is "FF\_C," but the "\_" (underscore character) is a symbol that indicates the format change. In this case, the characters will be recognized as separately as "FF" and "C."

**When the teaching results are not OK**

Touch [Next], and then touch the keys, explained below, on the [Select] screen to adjust or set the various items.

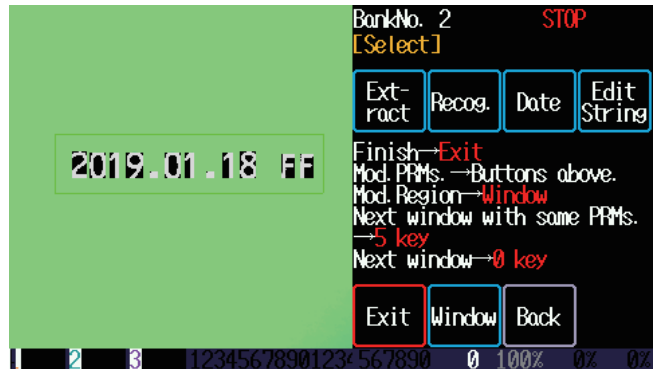
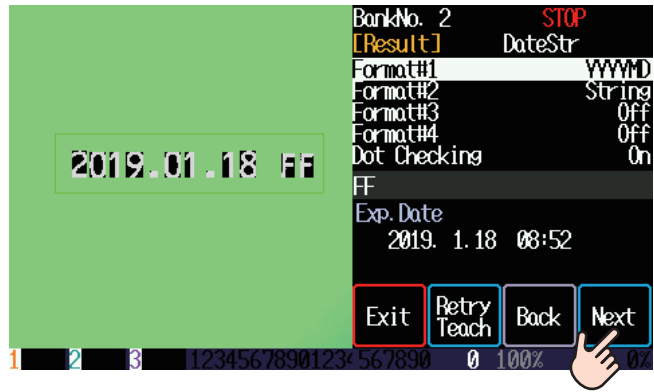

Setting item	Setting details	Reference page
Extract	Touch to configure detailed settings related to the character cutout.	6-18
Recog.	Touch to configure detailed settings related to the character recognition.	6-23
Date	Touch to configure detailed settings related to the date to be inspected.	6-28
Edit String	Touch to configure detailed settings related to the character string to be inspected.	6-31

# 4-3 Setup for Color Extraction

If the background of the inspection target has color or a colored pattern, perform an operation known as "color extraction" to separate and cut out the characters from the background color.

In this situation, enable color extraction prior to performing the setup, and then use the [Color] screen in the setup menu to extract the characters.

## 4-3-1 Enabling Color Extraction

1 On the operation screen, touch [Main Menu].

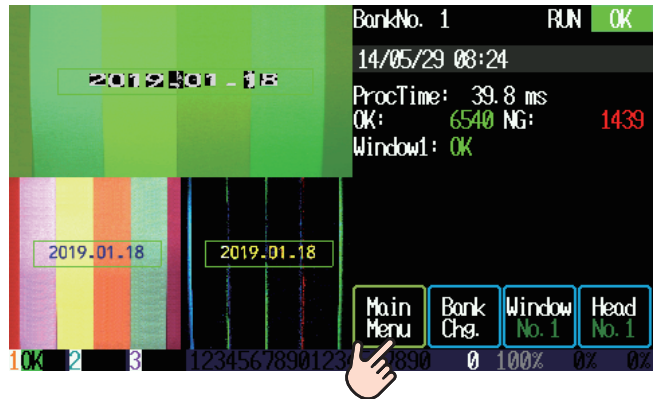

2 Touch [Settings].

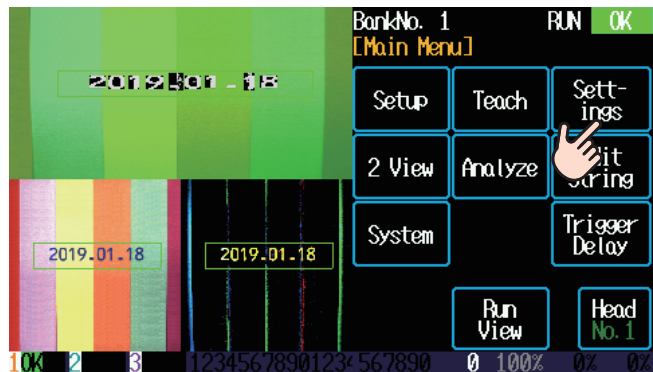

3 Touch [Extract].

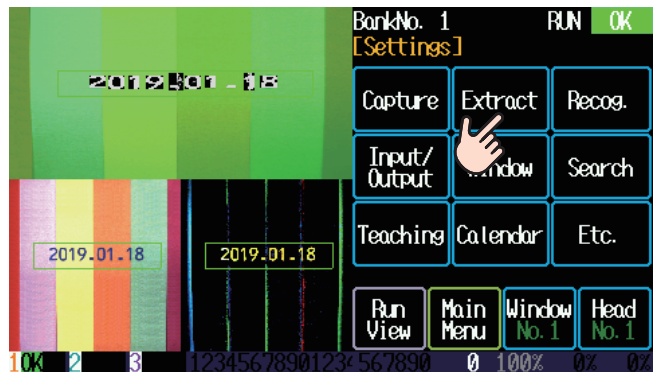

4 Touch [Color].

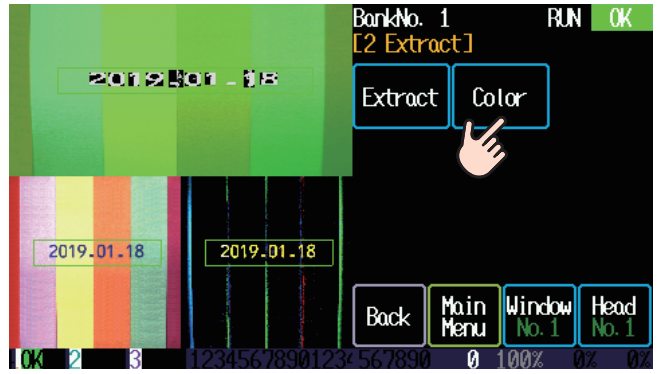

5 Touch [Color Off] to change the text on the key to [Color On].

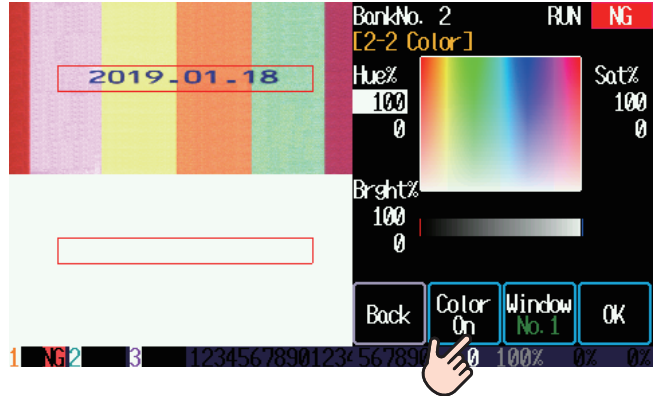

6 Touch [OK].

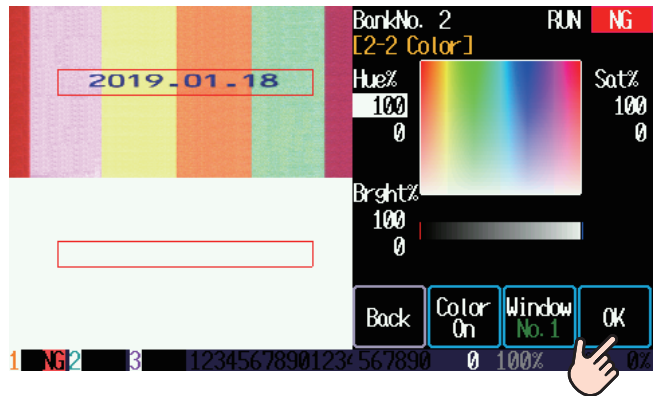

7 Touch [Back].



## 8

### Touch [Run View].

The device returns to the operation screen.

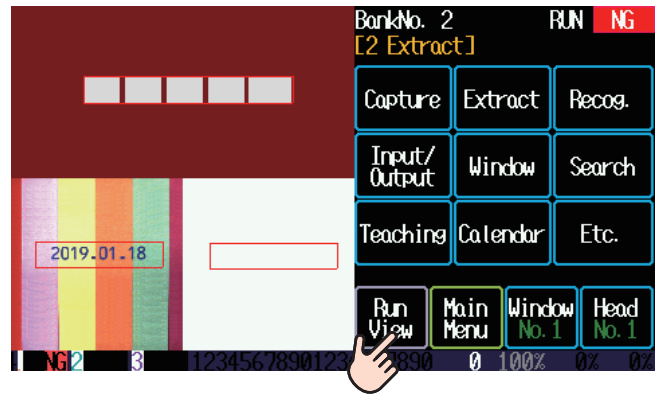

## 4-3-2 Starting the Setup Menu

This procedure is the same as in the standard setup.  
See "4-2-1 Starting the Setup Menu" (page 4-3).

## 4-3-3 Selecting the Bank

This procedure is the same as in the standard setup.  
See "4-2-2 Selecting the Bank" (page 4-4).

## 4-3-4 Configuring Settings for Capturing Images



This procedure is the same as in the standard setup.  
See "4-2-3 Configuring Settings for Capturing Images" (page 4-5).

## 4-3-5 Setting the Inspection Window

This procedure is the same as in the standard setup.  
See "4-2-4 Setting the Inspection Window" (page 4-13).

## 4-3-6 Performing Color Extraction

Perform color extraction to cut out the characters from the background.

- 1 On the [Color] screen, press the  and  keys to set the color extraction precision.

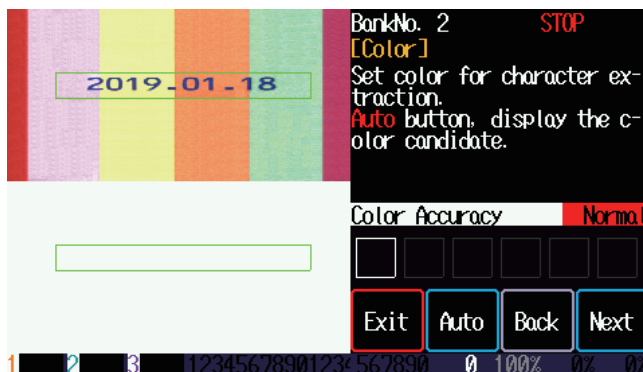

You can select one of the following values.

Setting	Details
Normal	Characters will be cut out with the standard recognition level.
Coarse	Characters will be cut out with a slightly rough recognition level.
Rough	Characters will be cut out with a rough recognition level.
Fineness	Characters will be cut out with a fine recognition level.
Detail	Characters will be cut out with a very fine recognition level.

- 2 Touch [Auto].

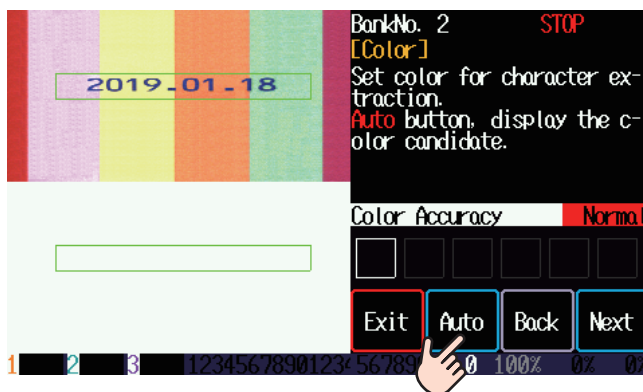

The colors that exist in the inspection target are displayed as candidate colors.

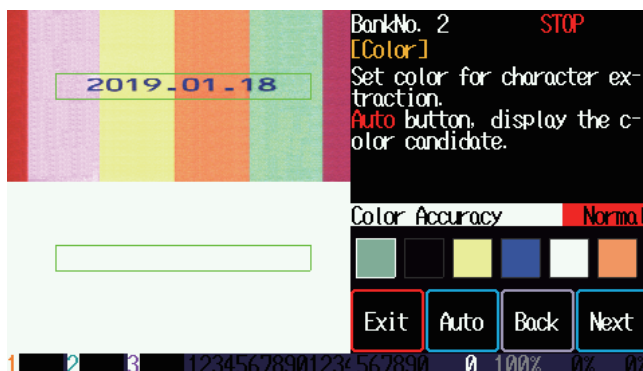

Change the color extraction precision and then touch [Auto] to display candidate colors that match the selected precision.

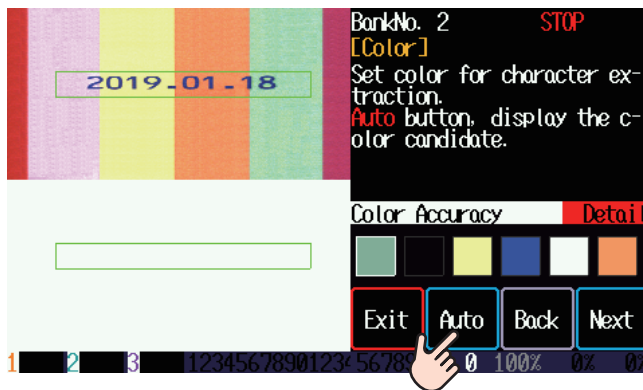

### MEMO

When you change the color extraction precision, be sure to execute the auto adjustment. If you do not execute the auto adjustment, the candidate colors will not be updated.

- 3 Touch the color in the candidate colors that corresponds to the color of the characters in the inspection target.



Select the color that makes the target characters appear in the lower screen of the camera image display.

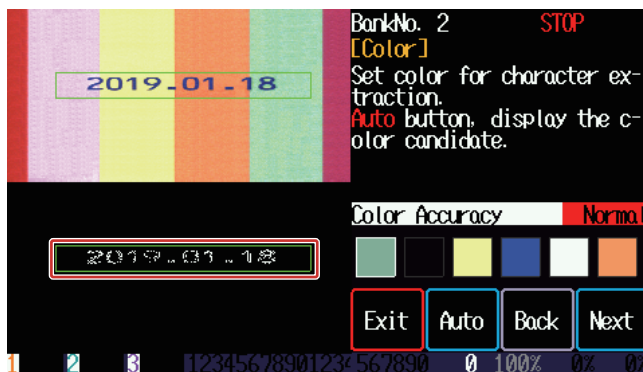

- 4 Touch [Next].



## 4-3-7 Performing Teaching

The procedure is the same as that for standard setup.  
See "4-2-5 Performing Teaching" (page 4-15).





---

# 5

## **Operation**

This chapter explains the operations that are performed while the device is running.

# 5-1 Select a Bank

Select the bank that you want to use.

Use one of the following four methods to select a bank.

- (1) Use the controller.
- (2) Use an external input
- (3) Use the communication port
- (4) Read a barcode

## 5-1-1 Select a Bank With the Controller

### Caution

To use this method, [Bank Select] must be set to "SEL." To confirm the [Bank Select] setting, touch [Settings], [Input/Output], and then touch [Input]. ("6-6-1 Input Settings" (page 6-47)).

### 1 Touch [Bank Chg.].

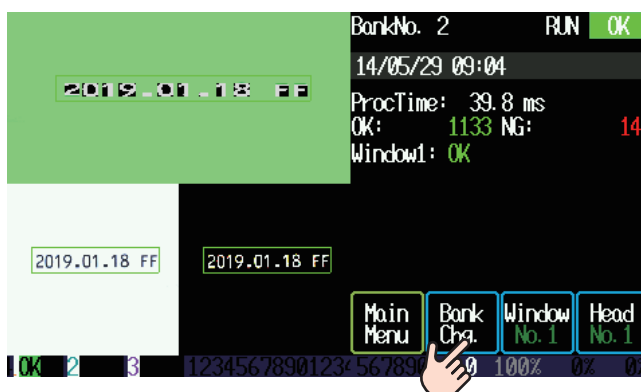

### 2 On the [Bank Select] screen, touch the bank or press the and keys to select the bank that you want to use.

The display will switch to the registered image of the selected bank.

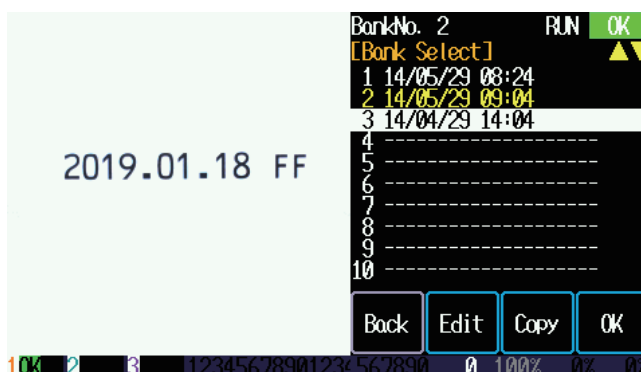

### MEMO

The currently selected bank is displayed in yellow.

### 3 Touch [OK].

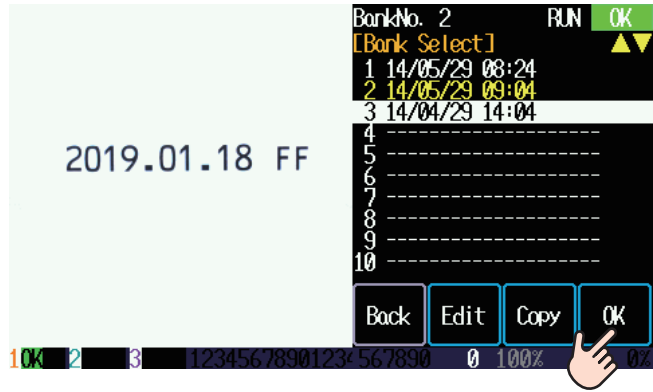

The selected bank is now active.



## Copy a bank

You can copy the settings in an existing bank to a different bank.

- 1 On the [Bank Select] screen, touch [Copy].

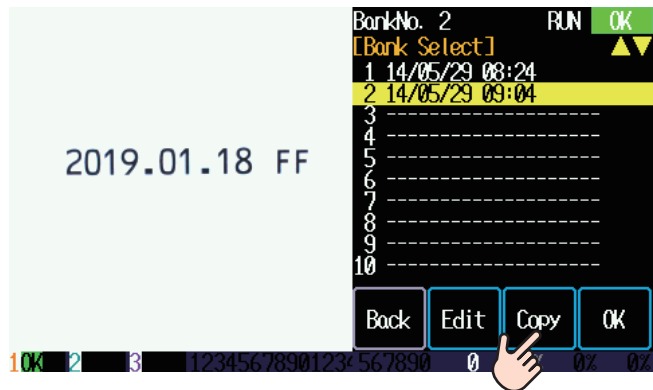

- 2 On the [Bank Copy] screen, press the **SET** key.



- 3** Use the **▼2** and **▲8** keys to select the bank to copy from, and then press the **SET** key.



- 4** Touch the screen or press the **▼2** key to move the cursor to [Destination]. Select the destination bank using the same procedure as step 3.  
If you select an existing bank, its settings will be overwritten.

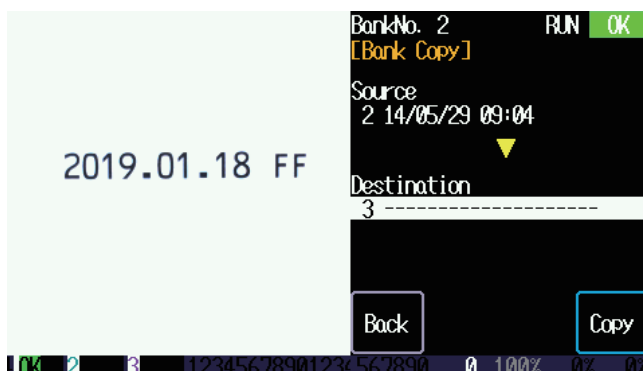

- 5** Touch [Copy].



The image is saved, and the setting details of the copy source bank are copied to the copy destination.

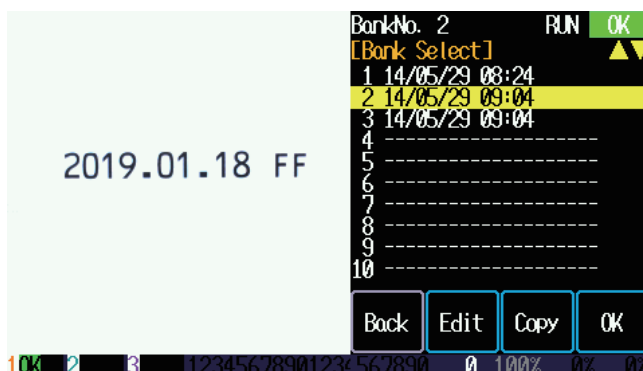

## ■ Add a comment to a bank

You can assign an arbitrary bank name and comment to a bank.

Use alphanumeric characters to enter comments.

- 1 On the [Bank Select] screen, select the bank that you want to add a comment to and touch [Edit].

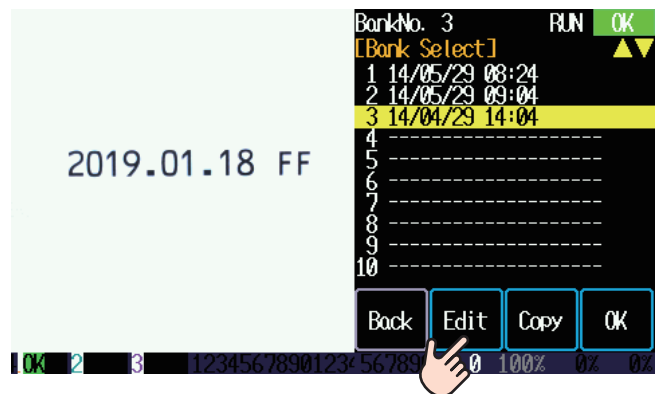

The [Bank Comment] screen displays with the current bank comment.

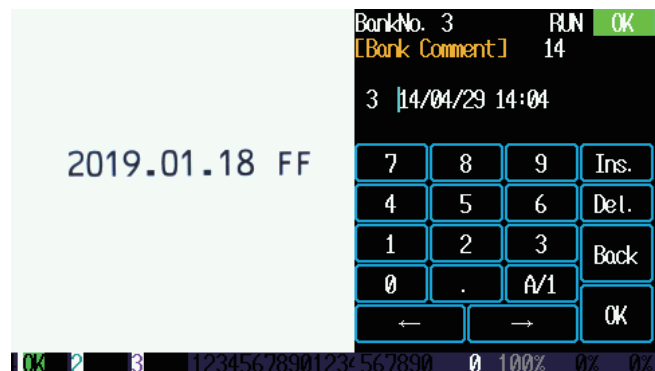

- 2 Touch [A/1] or [Aa] to switch the key display. Enter the comment.



### Switching the key display

Each time that you touch [A/1], the key display switches between numeric values and uppercase letters. To switch to lowercase letters, touch [Aa] while uppercase letters are displayed.

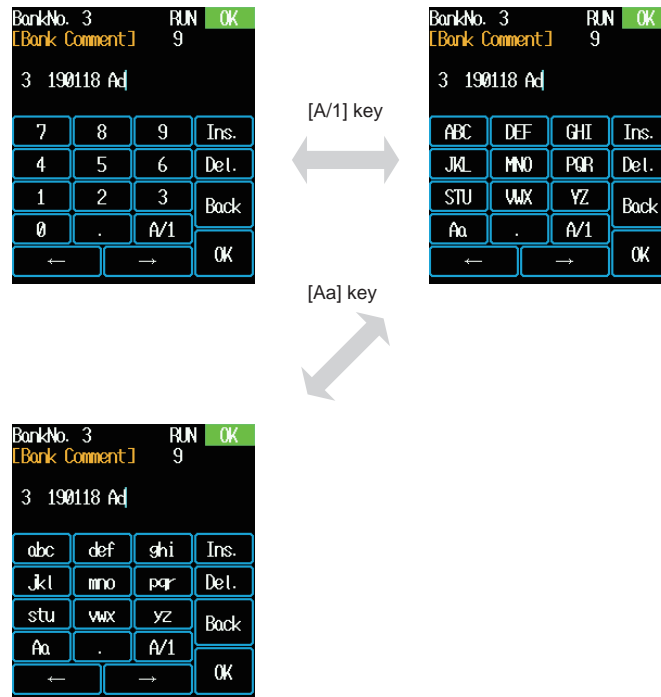

### Input method

When you touch a numeric or letter key once, the first character listed on the key is entered. If you touch the same key multiple times, each touch changes the character that is entered as shown below.

- If you touch [ABC]: A, B, C, A, etc.

The functions of the other keys are shown below.

Key	Function
.	Enters a symbol at the cursor position. Touch this key once and a period ("."), which is the first symbol, is entered. Touch the key multiple times and the symbol will change in the order shown below. ., /, :, _, ^, ?, ↓, ;, \, !, #, \$, %, &, (, ), *, +, -, <, =, >, @, [, ], "
Ins./Ovwt	Ins.: Inserts the entered character at the cursor position. Ovwt: Overwrites the character at the cursor position with the entered character.
Del.	Deletes the character in front of the cursor if the cursor is at the end of the string. Deletes the character at the cursor position if the cursor is in any other position.
Back	Discards the changes made to the comment and returns to the previous screen.
OK	Applies the changes made to the comment and returns to the previous screen.
←	Moves the cursor position one character to the left.
→	Move the cursor position one character to the right.

### 3 Touch [OK].

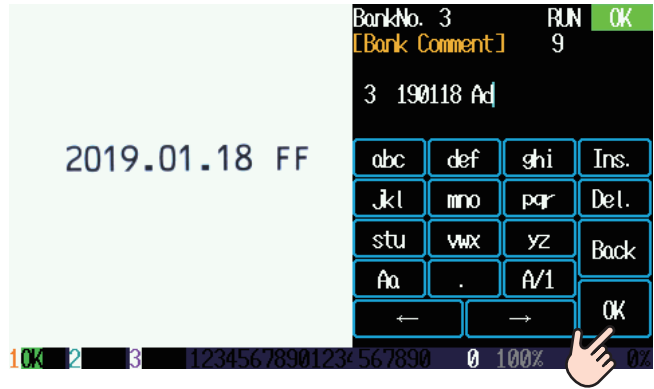

The comment is assigned to the bank.

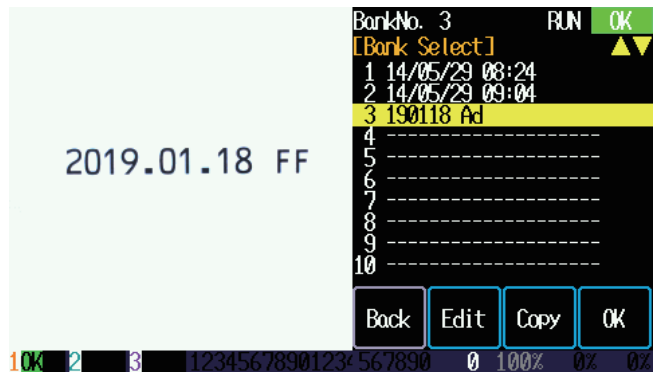

### MEMO

#### Add bank comments from a computer

You can use "Ocr2Capture," a software tool for use with the MVS-OCR2, to add bank comments.

For details, see the user's manual included with "Ocr2Capture."

## 5-1-2 Select a Bank Using External Input

### Caution

To use this method, [Bank Select] must be set to "PORT." To confirm the [Bank Select] setting, touch [Settings], [Input/Output], and then touch [Input]. ("6-6-1 Input Settings" (page 6-47))

- 1 Connect the I/O connector cable to the expansion I/O connector on the controller.

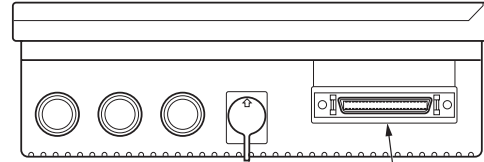

Expansion I/O connector

- 2 Identify the leads of each terminal using the following figure and table. Connect the external device to the target terminals.

(Example)



Expansion I/O terminal	Lead		
	Coating color	Dot color	Number of dots
EX1	Orange	Black	4
EX2	Gray		
EX3	White		
EX4	Yellow		
EX5	Pink		
EX6	Orange		Continuous
EX7	Gray		
EX8	White		
EX9	Yellow		
EX10	Pink		
T11	White		1
T12	Orange		2
T13	Yellow		2

### 3

To select a bank, set the ON/OFF input signals using the following table.

Bank number	Expansion I/O input EX					Parity
	n	n + 1	n + 2	n + 3	n + 4	
1	OFF	OFF	OFF	OFF	OFF	ON
2	ON	OFF	OFF	OFF	OFF	OFF
3	OFF	ON	OFF	OFF	OFF	OFF
4	ON	ON	OFF	OFF	OFF	ON
5	OFF	OFF	ON	OFF	OFF	OFF
6	ON	OFF	ON	OFF	OFF	ON
7	OFF	ON	ON	OFF	OFF	ON
8	ON	ON	ON	OFF	OFF	OFF
9	OFF	OFF	OFF	ON	OFF	OFF
10	ON	OFF	OFF	ON	OFF	ON
11	OFF	ON	OFF	ON	OFF	ON
12	ON	ON	OFF	ON	OFF	OFF
13	OFF	OFF	ON	ON	OFF	ON
14	ON	OFF	ON	ON	OFF	OFF
15	OFF	ON	ON	ON	OFF	OFF
16	ON	ON	ON	ON	OFF	ON
17	OFF	OFF	OFF	OFF	ON	OFF
18	ON	OFF	OFF	OFF	ON	ON
19	OFF	ON	OFF	OFF	ON	ON
20	ON	ON	OFF	OFF	ON	OFF
21	OFF	OFF	ON	OFF	ON	ON
22	ON	OFF	ON	OFF	ON	OFF
23	OFF	ON	ON	OFF	ON	OFF
24	ON	ON	ON	OFF	ON	ON
25	OFF	OFF	OFF	ON	ON	ON
26	ON	OFF	OFF	ON	ON	OFF
27	OFF	ON	OFF	ON	ON	OFF
28	ON	ON	OFF	ON	ON	ON
29	OFF	OFF	ON	ON	ON	OFF
30	ON	OFF	ON	ON	ON	ON
31	OFF	ON	ON	ON	ON	ON
32	ON	ON	ON	ON	ON	OFF

## 5-1-3 Other Bank Selection Methods

You can use the following methods to select the bank.

<b>Selecting the bank using communication</b>	See "■ Switching the bank" in "8-1-3 Communication Commands" (page 8-4).
<b>Selecting the bank by reading a barcode</b>	See "■ Selecting the bank by reading a barcode" in "7-7-12 Barcode Link Function Setting Example" (page 7-33).

# 5-2 Displaying NG Images

This section explains how to load NG images that have been saved to the controller's memory. You can display up to 10 screens of NG images in order from the most recent image.

- 1 On the [Main Menu] screen, touch [2 View].

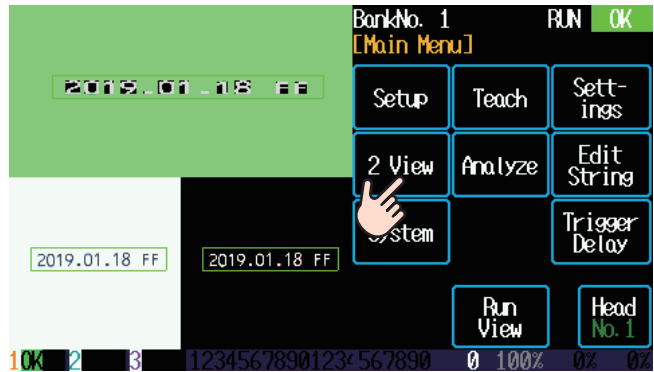

Images are displayed on two screens (the current judgment image on the upper screen and the NG image on the lower screen).



## MEMO

You can also display NG images while the device is operating.

Touch [Result Image] or [RAW Image] to switch the lower image to the judgment image or the raw image.

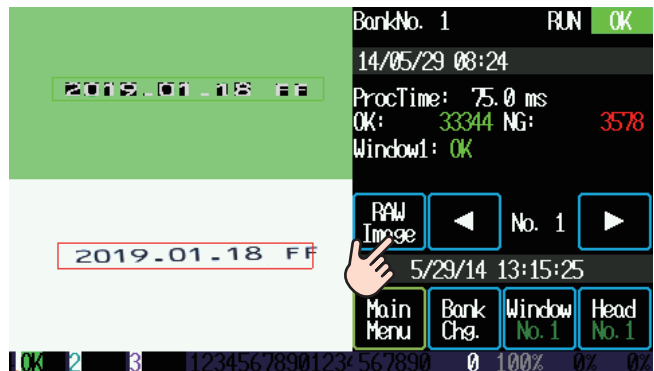

Touch [◀] and [▶] to switch the image.



## MEMO

- This procedure displays NG images that have been temporarily saved to memory. When you turn off the controller, the images are deleted.

### NG images when using the "Multi Judge" setting

- The "Multi Judge" setting (see "6-3-1 Camera Unit Settings" (page 6-8)) can be used to judge whether a batch of continuous images receives an overall judgment of OK according to the number of individual images in the batch that are OK. An image is saved when the "Multi Judge" setting is specified, but the saved image is only the final image in the batch of captured images. Therefore, images that are NG may not be saved.

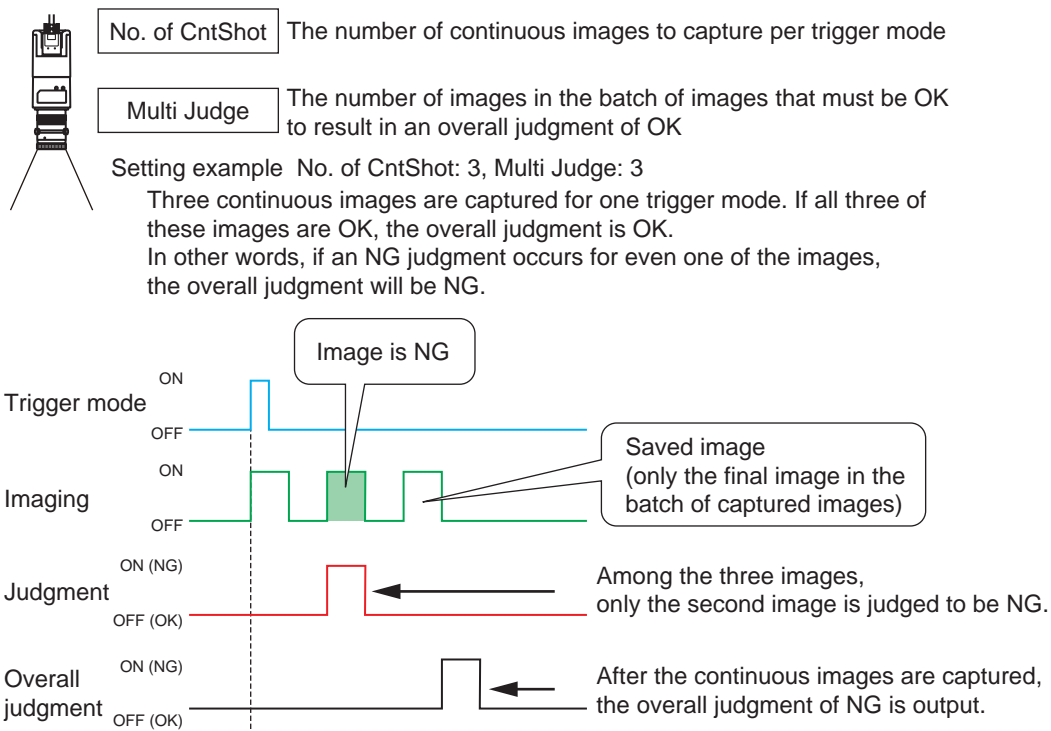

As shown above, when the "Multi Judge" setting is specified, the image saved when an NG judgment occurs may not be the image that was judged to be NG.

# 5-3 Analyzing NG Images

This section explains how to load an NG image that has been saved to the camera's nonvolatile memory and how to display the failure analysis screen.

You can change the setting values for the displayed NG image and then immediately apply the result to the current judgment conditions.

## MEMO

If [Save Image] is set to "Off," images will not be saved. To confirm the [Save Image] setting, touch [Settings] and then [Etc.]. You can save the following types of images: all images, all failed images, and all images that switch from OK to NG. For details, see "6-11 Other Settings" (page 6-69).

1 On the [Main Menu] screen, touch [Analyze].

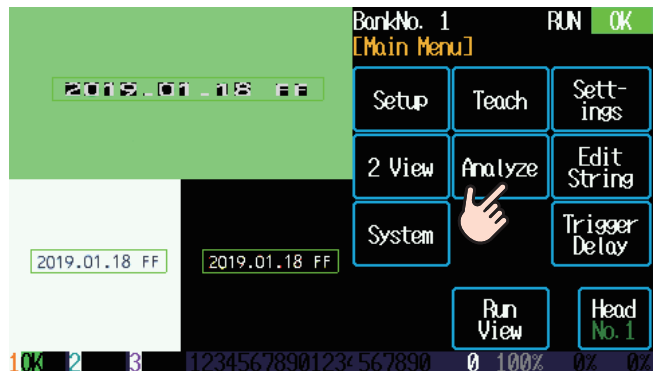

2 Touch [OK].



## MEMO

During failure analysis, the device stops operating.

3 Select the image for analysis.

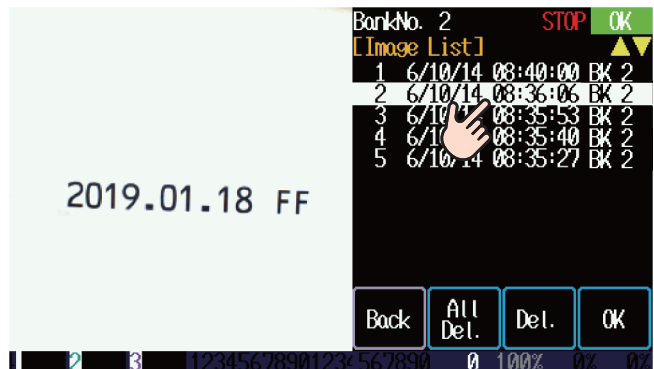

## 4 Touch [OK].



The selected NG image is displayed.

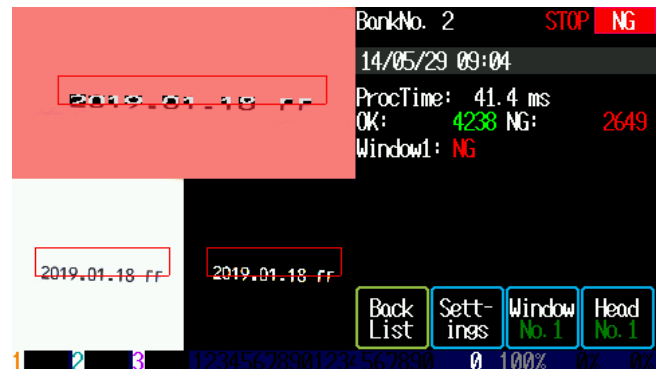

## 5 To change the settings, touch [Settings] and then change the values.

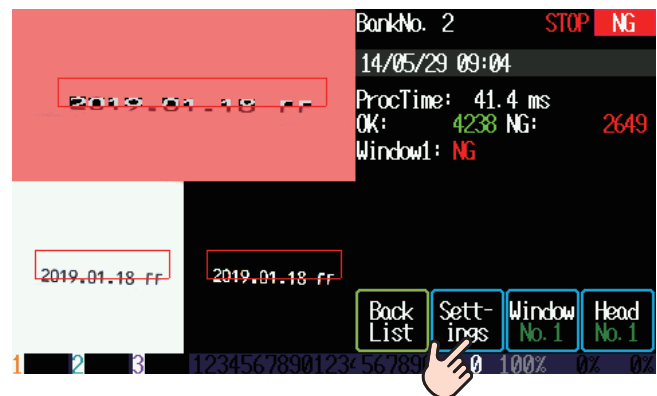

(Example) Expanding the inspection window range

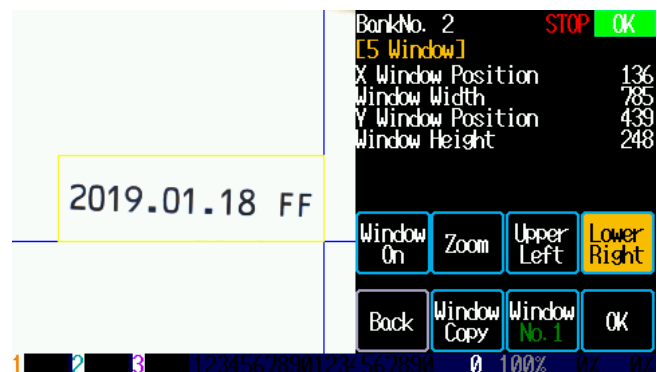

## MEMO

Touch [Back List] to select a different image.

## 6 Touch [OK].

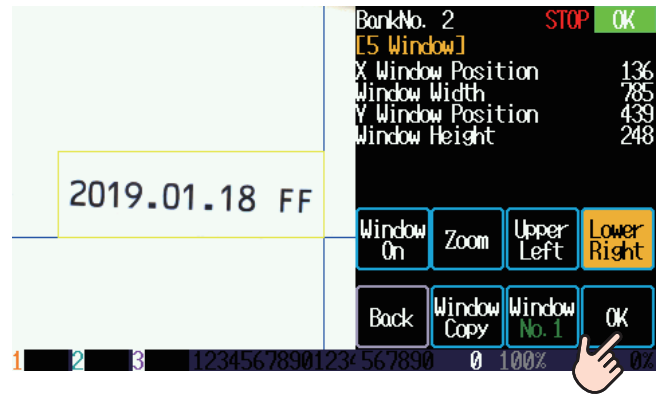

The changed settings are applied to the current judgment conditions.

## 7 After you finish performing the failure analysis, touch [Back List], and then touch [Back].

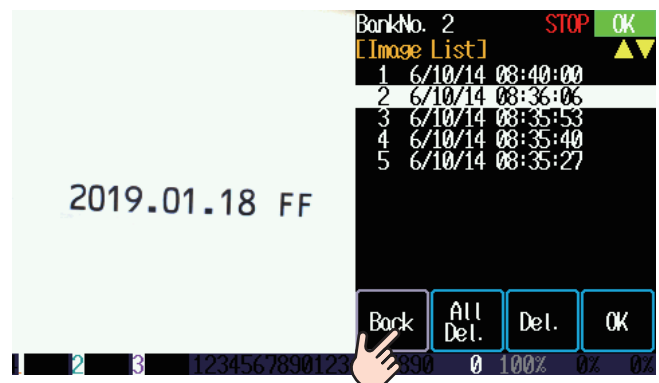
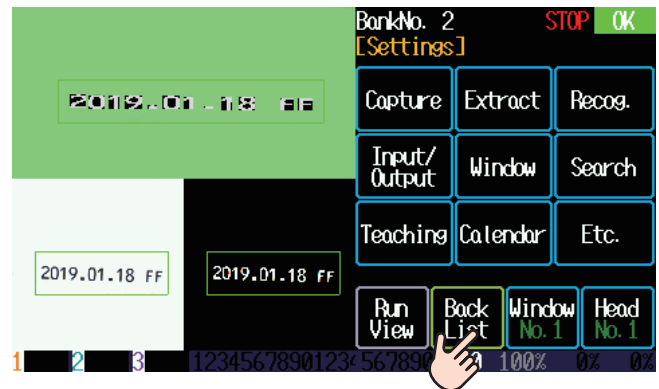
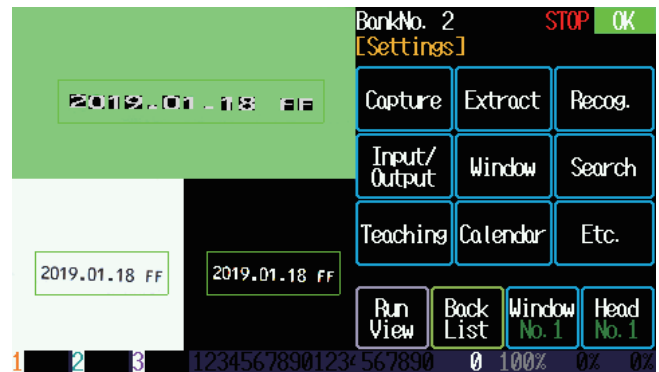





---

# 6

## **Settings**

This chapter explains the settings of each parameter.

# 6-1 Settings

The settings on this device are classified into the groups shown below.

Major item	Medium item	Minor item	Settings	Reference page
Capture	Camera		Image capture	6-8
	Lighting		Lighting	6-11
	Pre-Proc.		Character extraction preprocessing	6-13
	Shading		Illuminance correction	6-15
	Save Image		Registering the reference image	6-16
Extract	Extract		Character cutout	6-18
	Color		Color extraction	6-21
Recog.	Recog.		Character recognition	6-23
	Date		Date	6-28
	Edit String		Editing the read character string	6-31
	Tables	Year Month Day Hour Minute	The replacement table used to convert character strings to normal numeric values when the date has been encrypted as a character string	6-36
		Severe	The strictness table that determines the strictness for each character	
	Dictionary		The extended dictionary	6-43
Input/Output	Input		Input	6-47
	Input Test		Testing the continuity of the input terminals	6-54
	Output		Output	6-51
	Output Test		Testing the continuity of the output terminals	6-55
Window			The inspection window	6-57
Search	Search Window		The search region	6-60
	Search Setting		Searching	
Teaching			Teaching	6-66
Calendar			The calendar timer	6-68
Etc.			Other items	6-69

## ■ Setting item index function

When the main menu is displayed, press the **[?]** key to display the alphabetic index of the setting item. You can use the index to switch the screen to the necessary setting item.

### 1 Display the main menu, and then press the **[?]** key.

The alphabetic index of the setting item is displayed.



### 2 Use the **[4]** and **[5]** keys to select the heading.

The displayed headings switch in the order of [symbols and numbers] → [A to Z].



### 3 Use the **[2]** and **[8]** keys to find the target setting item.



## 4 Touch [OK].

The display switches to the screen of the selected setting item.



## MEMO

With the index function settings, the cursor highlight color changes as you move the cursor between different setting items. This indicates the applicable range of the setting.

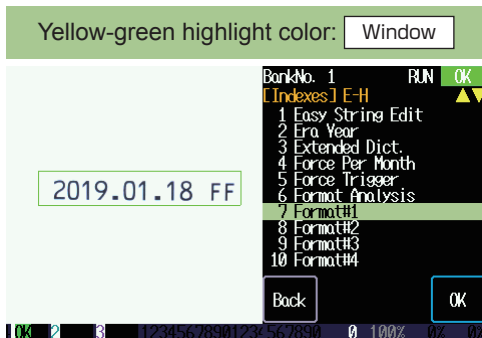
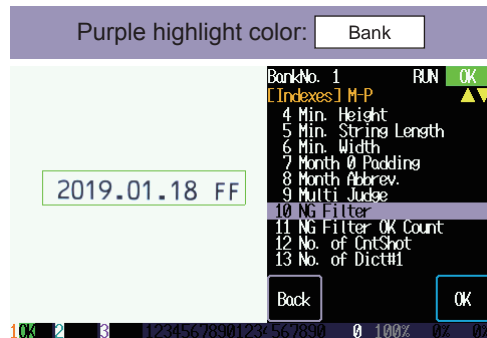
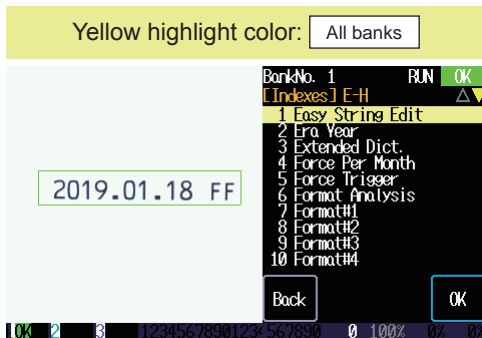

# 6-2 Configure Settings

Follow the procedure shown below to configure settings.

- 1 On the operation screen, touch [Main Menu].

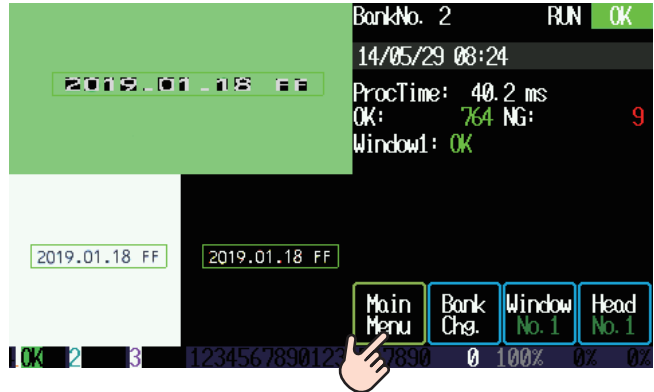

- 2 On the [Main Menu] screen, touch [Settings].

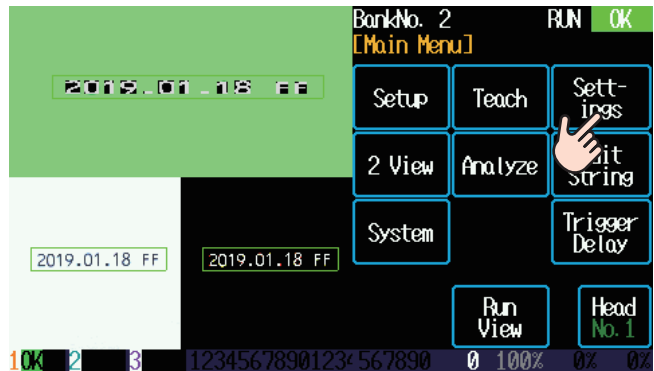

- 3 Touch the key for the item that includes the setting that you want to configure.

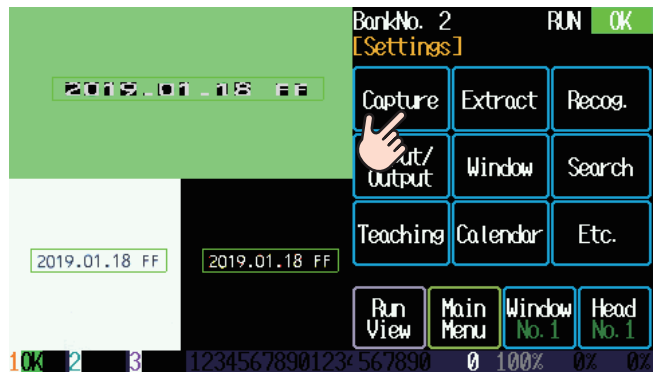

- 4** Touch the key for the item that includes the setting that you want to configure.

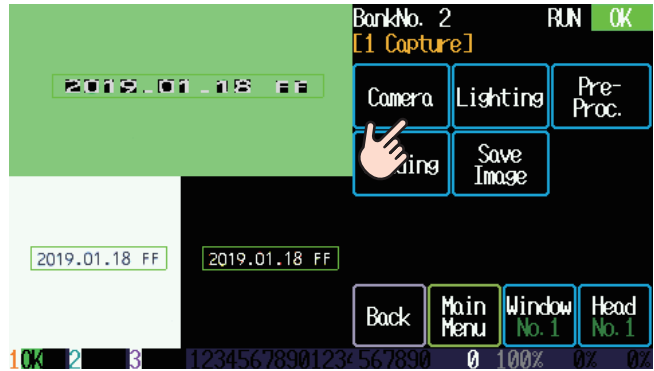

**MEMO**

- Touch [Back] to display the previous item.
- Touch [Main Menu] to return to the main menu.

- 5** Touch the item that you want to set or use the **▼** and **▲** keys to specify the item, and then press the **SET** key.

The selected item is displayed in red.

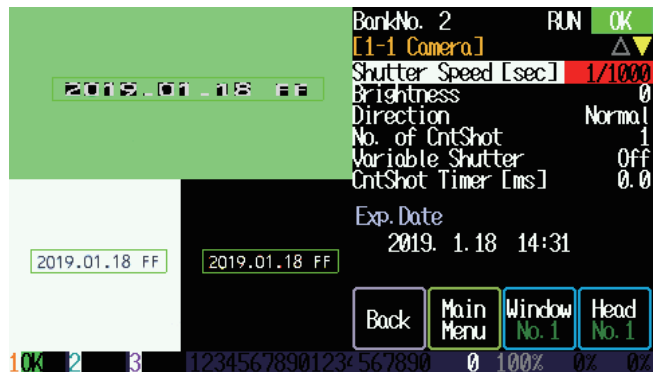

**MEMO**

Touch the display below the setting item to switch between the display of details such as the 7 × 7 dot character display and the match rate.

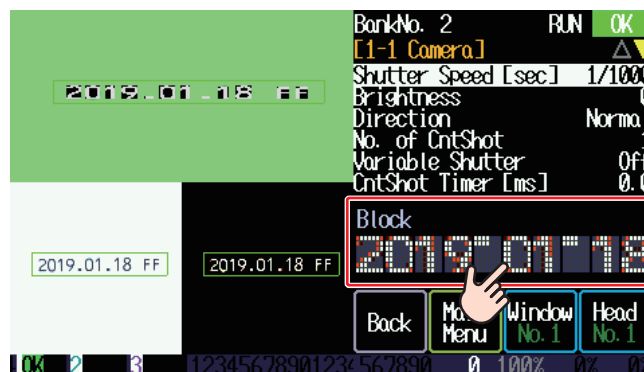

- 6** Use the numeric keypad to set the value and then press the **SET** key. The setting value is confirmed.

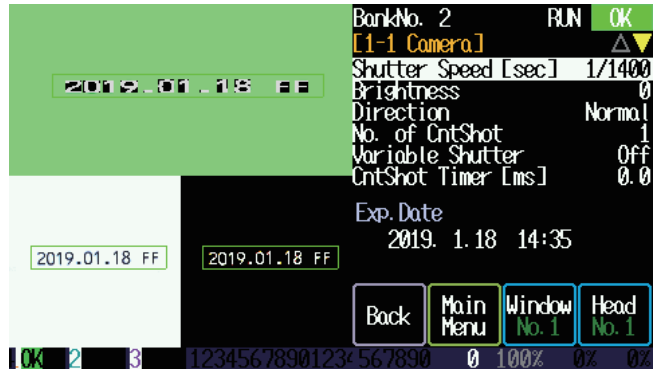

**MEMO**

For details on this setting method, see "3-2-2 Numeric Keypad Operations" (page 3-12).

# 6-3 Image Capture Settings

This section explains how to configure the image capture settings.

- 1 On the [Settings] screen, touch [Capture].

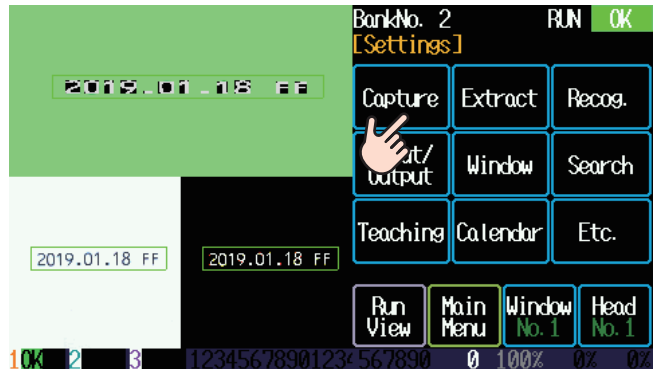

## 6-3-1 Camera Unit Settings

The section explains how to configure the camera unit settings for image capture.

- 1 On the [1 Capture] screen, touch [Camera].

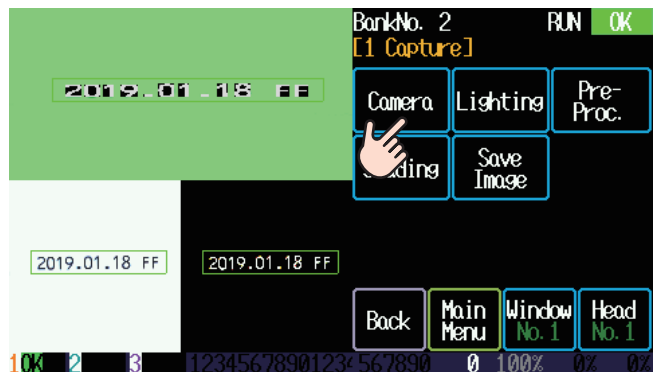

- 2 Select an item.

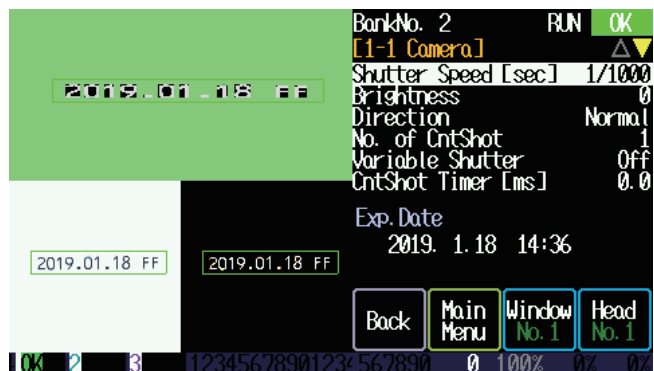

### MEMO

Press the  or  key to display the setting details of the previous or next group, respectively.

The setting items and their corresponding details are shown below.

Setting	Details	Setting value (Default values in bold)	Applies to
Shutter Speed [sec]	Set the shutter time (speed). Smaller values are better for fast-moving workpieces.	1/7, 1/10, 1/15, 1/21, 1/30, 1/42, 1/60, 1/85, 1/120, 1/170, 1/240, 1/350, 1/500, 1/700, <b>1/1000</b> , 1/1400, 1/2000, 1/2800, 1/5500, 1/7000, 1/9200, 1/13800, 1/27500 (seconds)	<input type="text" value="Bank"/>
Brightness	Set the brightness of the captured image. The larger the value, the brighter the image. However, increasing the value also increases the image noise.	<b>0</b> to 255	<input type="text" value="Bank"/>
Direction	Set the direction of the captured image. Configure this setting so that the characters on the screen are displayed in an upright manner. The direction that you set here will also be applied to the registered image.	<b>Normal</b> ; RTT. 90; RTT. 180; RTT. 270; MIRR.; MIRR. 90; MIRR. 180; MIRR. 270	<input type="text" value="Bank"/>
No. of CntShot	Set the number of images to capture with a single trigger. Captured images are judged in order. Image capture stops when the judgement result is OK. Use this setting when character recognition is unstable. Set this to "1" to return to single image capture.	<b>1</b> to 8 (images)	<input type="text" value="Bank"/>
Variable Shutter	Set the shutter speed for continuous image capture. This setting is enabled when [No. of CntShot] is set to a value other than "1." Use this setting when the ambient light is fluctuating.	<b>Off</b> , ±4%, ±8%, ±12%	<input type="text" value="Bank"/>
CntShot Timer [ms]	Set the interval between captured images. When [No. of CntShot] is set to a value other than "1," set the interval time between captured images. The value is set in units of 0.1 ms (100 μs).	<b>0.0</b> to 1000.0 (ms)	<input type="text" value="Bank"/>
Multi Judge	Set the number of images among a batch of continuous captured images that must have an OK judgment in order for the overall judgment to be OK. This setting is enabled when [No. of CntShot] is set to a value other than "1."	<b>1</b> , All, 2 to 8	<input type="text" value="Bank"/>
Region of Interest	Set whether to read the background outside of the inspection window. "All:" All of the background will be read. "No Bg.:" The background will be cut out. The time required to read images will be shorter.	<b>All</b> , No Bg.	<input type="text" value="Bank"/>
X Sensor Position	Set the horizontal position of the captured image.	6 to <b>134</b> to 262	<input type="text" value="All banks"/>
Y angle	Correct the keystone distortion of the image (toward the top or bottom of the screen) when the camera must be installed at an angle to the workpiece.	-15 to <b>0</b> to 15	<input type="text" value="Bank"/>

### MEMO

When [Multi Judge] is set to a value other than "1," the image saved when the NG judgment occurs is the last image in the batch of continuous images captured. For details, see "NG images when using the "Multi Judge" setting" (page 5-12).

## 6-3-2 Correcting the Camera Installation Angle

When you have to install the camera at an angle due to the equipment and devices, correct the angled captured image so that character cutout can be performed normally.

- 1 On the [1 Capture] screen, touch [Camera].



- 2 Touch [Y angle].

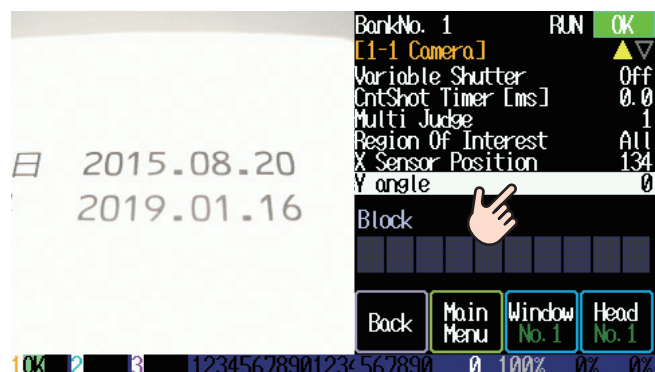

- 3 Adjust the value until the characters on the screen are straight.

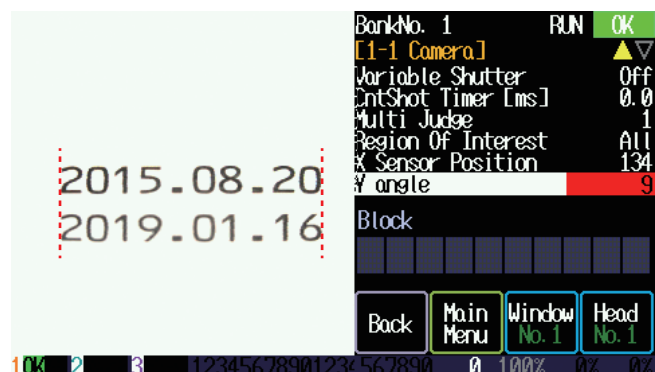

### MEMO

When you correct the captured image with [Y angle], the imaging field of view will be narrowed and the aspect ratio of the characters will differ from that of the actual printed characters.

## 6-3-3 Lighting Settings

This section explains how to configure the settings for lighting.

- 1 On the [1 Capture] screen, touch [Lighting].

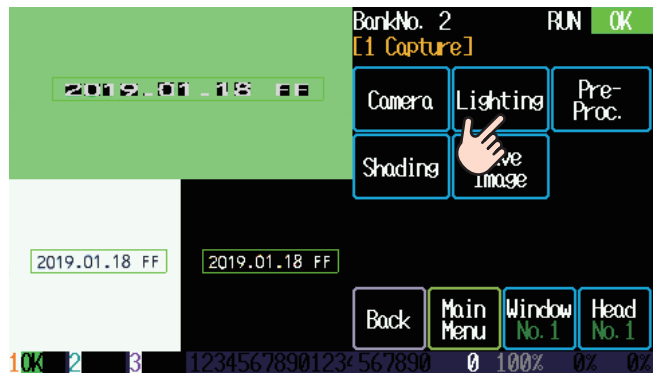

- 2 Select an item.

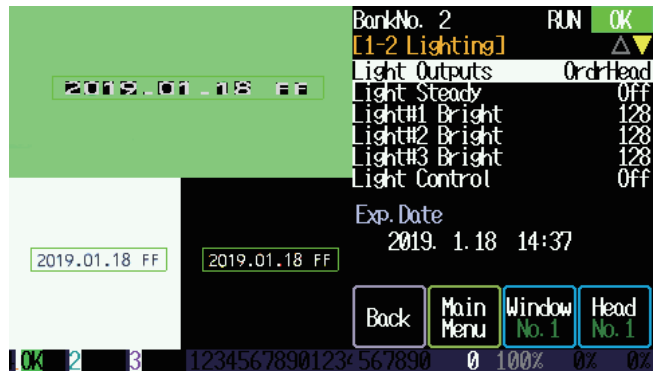

The setting items and their corresponding details are shown below.

Setting item	Setting details	Setting value (Values in bold are default values.)	Applies to
Light Outputs	Set the light output to use. To assign lighting cables 1 to 3, in order, to the head numbers, set the value to "OrdrHead." To use multiple lights with a single head, set a combination of values, such as "No. 1+2."	Off, <b>OrdrHead</b> , No. 1, No. 2, No. 1+2, No. 3, No. 1+3, No. 2+3, No. 1+2+3	<input type="text" value="Bank"/>
Light Steady	Set the light to be always on or flashing in sync with the shutter speed. "On:" The light will be always on. "Off:" The light will be flashing.	On, <b>Off</b>	<input type="text" value="All banks"/>
Light#1 Bright	Set the brightness of the light connected to lighting cable connector 1. Over time, the brightness decreases, so set a high value to compensate when the image becomes dark.	0 to <b>128</b> to 255	<input type="text" value="Bank"/>
Light#2 Bright	Set the brightness of the light connected to lighting cable connector 2. Over time, the brightness decreases, so set a high value to compensate when the image becomes dark.		<input type="text" value="Bank"/>
Light#3 Bright	Set the brightness of the light connected to lighting cable connector 3. Over time, the brightness decreases, so set a high value to compensate when the image becomes dark.		<input type="text" value="Bank"/>
Light Control	Set to generate light control signals from the OK output terminals (OK1 to OK3) and from the NG output terminals (NG1 to NG3) of the terminal block. Set this value when you are using an external power supply with the LED light.	<b>Off</b> , OK1, NG1, OK2, NG2, OK3, NG3	<input type="text" value="All banks"/>
Light Polarity	Set whether the light turns on or off when the light control signal is set to ON or OFF. "Normal:" When the light control signal is set to ON, the light turns on, when the signal is set to OFF, the light turns off. "Invert:" When the light control signal is set to ON, the light turns off, when the signal is set to OFF, the light turns on. Set this value to match the input specifications when you are using an external power supply with the light.	<b>Normal</b> , RTT. 180	<input type="text" value="All banks"/>

## 6-3-4 Preprocessing Settings

This section explains how to configure the settings for character extraction preprocessing.

- 1 On the [1 Capture] screen, touch [Pre-Proc.].

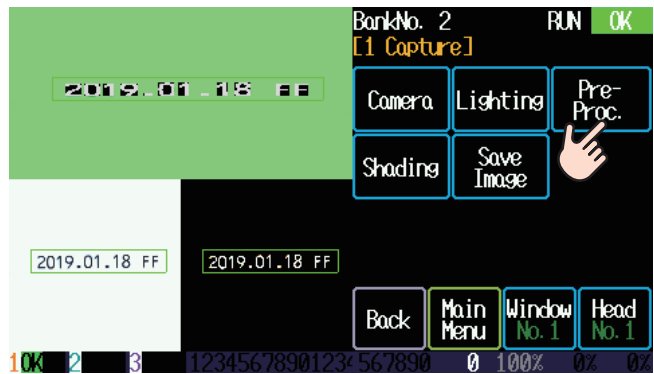

- 2 Select an item.

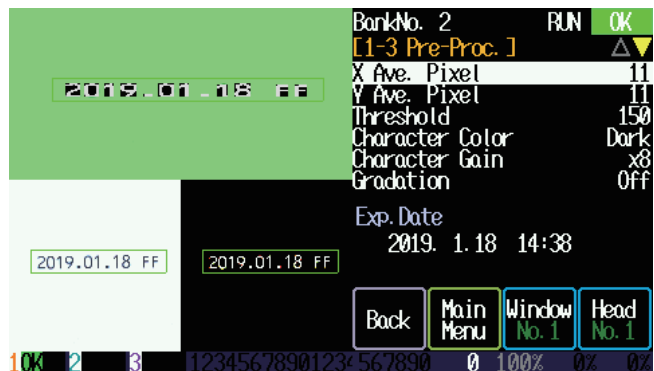

The setting items and their corresponding details are shown below.

Setting item	Setting details	Setting value (Values in bold are default values.)	Applies to
X Ave. Pixel	Set the horizontal range to reference during character extraction. When a dense background is present to the left or right of the characters, enter a small value so that only the characters are extracted.	0 to <b>11</b> to 15	<input type="text" value="Bank"/>
Y Ave. Pixel	Set the vertical range to reference during character extraction. When a dense background is present above or below the characters, enter a small value so that only the characters are extracted.	0 to <b>11</b> to 15	<input type="text" value="Bank"/>
Threshold	Set to extract characters from locations where the difference in density compared to the background is greater than or equal to this value.	0 to <b>150</b> to 255	<input type="text" value="Bank"/>
Character Color	Set to search for dark-colored characters on a bright-colored background or search for bright-colored characters on a dark-colored background. "Dark:" The inspection will search for dark-colored characters on a bright-colored background. "Bright:" The inspection will search for bright-colored characters on a dark-colored background.	<b>Dark</b> , Bright	<input type="text" value="Bank"/>
Character Gain	Set when you want to improve the accuracy of character cutouts by emphasizing the character extraction result. However, specifying a setting value that is too high will result in poor image quality.	×1, ×2, ×4, <b>×8</b> , ×16, ×32	<input type="text" value="Bank"/>
Gradation	Zoom in on the image to the set gradation in order to stabilize the extraction of light characters and of characters on dark backgrounds.	<b>Off</b> , 16, 32, 64, 128, 256	<input type="text" value="Bank"/>
Grad. Low Limit	Set the lower gradation limit that was set with [Gradation].	<b>0</b> to 255	<input type="text" value="Bank"/>





## 6-3-5 Illuminance Correction Settings

This section explains how to configure the settings for illuminance correction.

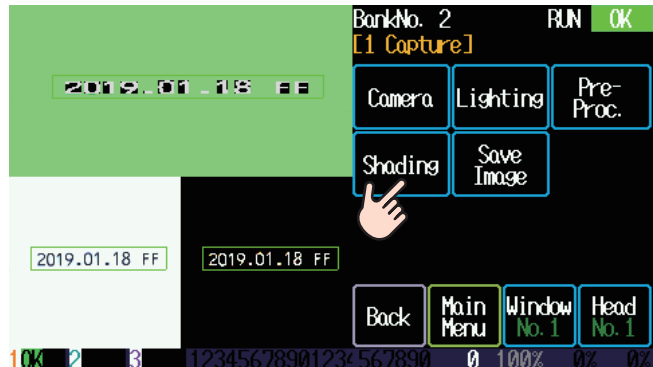

Configure these settings when there are gaps in the brightness of the light, such as when only certain parts of the image are dark.

- 1 On the [1 Capture] screen, touch [Shading].

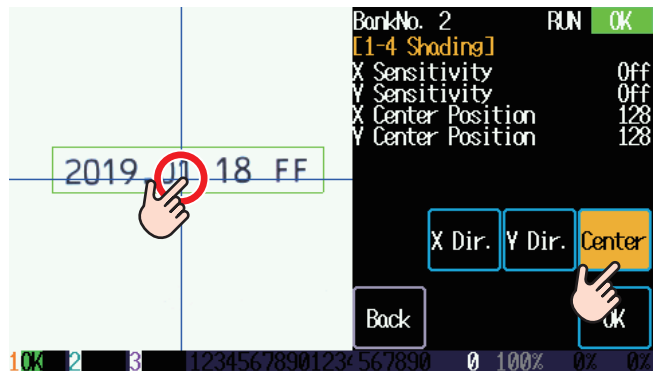

- 2 Touch [Center], and then touch the point to use as the center of the correction. You can also use the , , , and  keys to set this point.



- 3 Touch [X Dir.] or [Y Dir.], and then use the  and  keys to set the sensitivity.

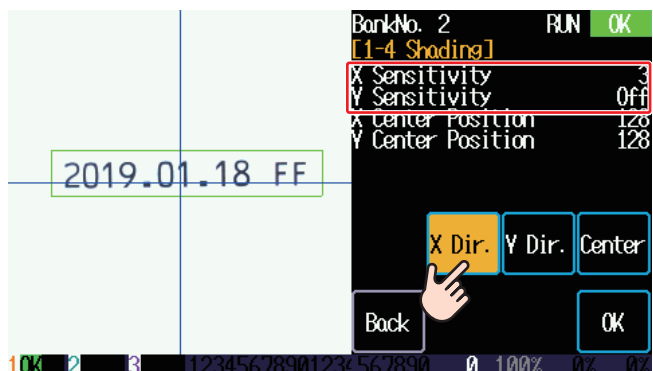

The setting items and their corresponding details are shown below.

Setting item	Setting details	Setting value (Values in bold are default values.)
X Sensitivity	Adjust the brightness of the light in the horizontal direction.	-7 to <b>Off</b> to +7
Y Sensitivity	Adjust the brightness of the light in the vertical direction.	-7 to <b>Off</b> to +7
X Center Position	Set the reference point in the horizontal direction for use in adjusting the brightness.	0 to <b>128</b> to 255
Y Center Position	Set the reference point in the vertical direction for use in adjusting the brightness.	0 to <b>128</b> to 255

## 4 Touch [OK].

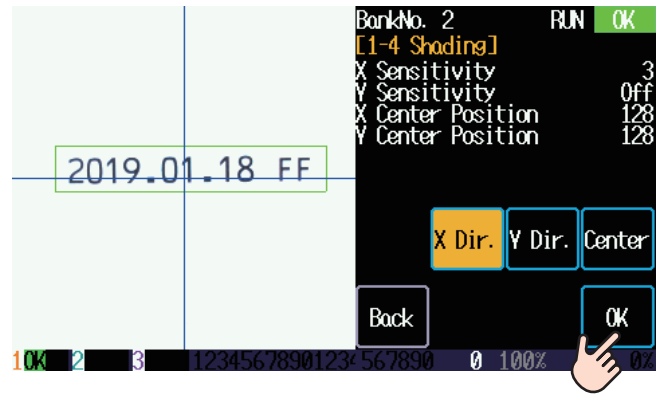

## 6-3-6 Register the Reference Image

This section explains how to register the image to use as the reference image of the currently selected bank. You can select from the following three types of registered images.

- Captured image: Capture the currently displayed image, and then set this image as the registered image.
- Image saved to memory: Load an image saved to memory, and then set this image as the registered image.
- Bank-registered image: Load an image registered to another bank, and then set this image as the registered image.

- 1 On the [1 Capture] screen, touch [Save Image].

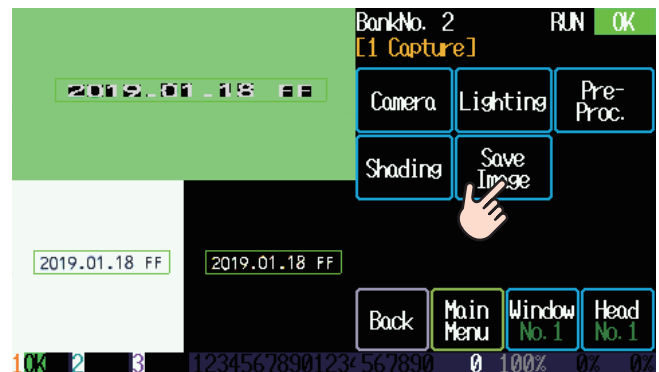

- 2 Touch [Snapshot], [Saved No. X], or [Bank No. X] to select the type of image to register.

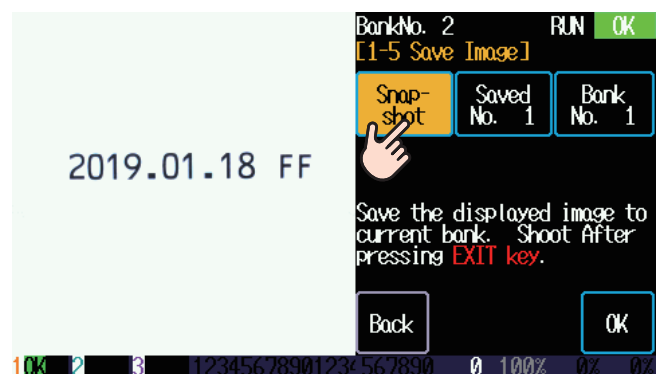

### MEMO

If there are no images saved to memory, the [Saved No. X] key will be disabled.

When [Snapshot] is selected:  
Register the currently displayed image.

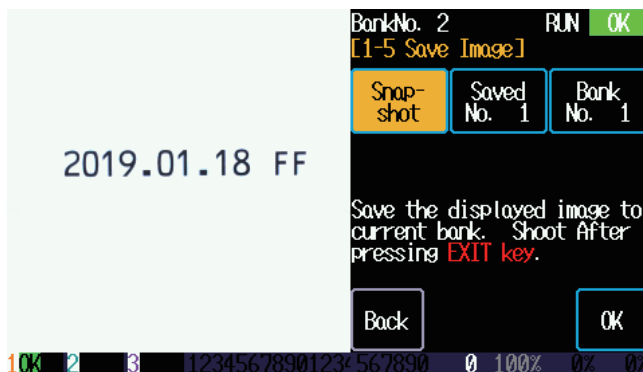

### MEMO

When you press the **EXIT** key, the currently displayed image will be captured.

When [Saved No. X] is selected:  
Register an image saved to memory.  
Use the **Y2** and **A8** keys to select the image.



### MEMO

When you press the **EXIT** key, the currently displayed image will be captured.

When [Bank No. X] is selected:  
Register an image registered to another bank.  
Use the **Y2** and **A8** keys to select the bank.

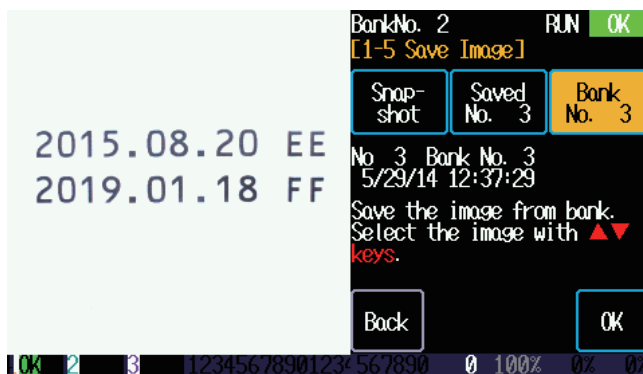

**3** Touch [OK].

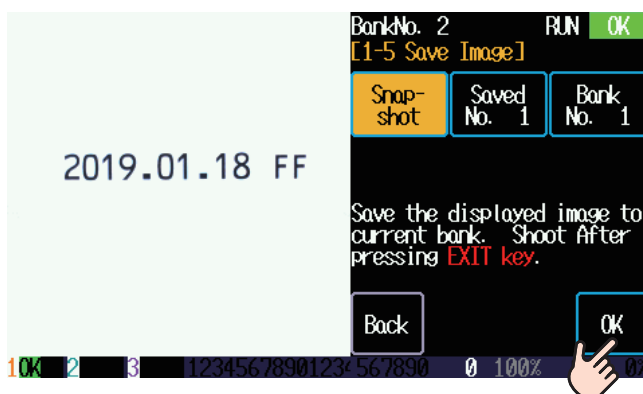

# 6-4 Cutout Settings

This section explains how to configure the settings for character cutout and color extraction.

- 1 On the [Settings] screen, touch [Extract].

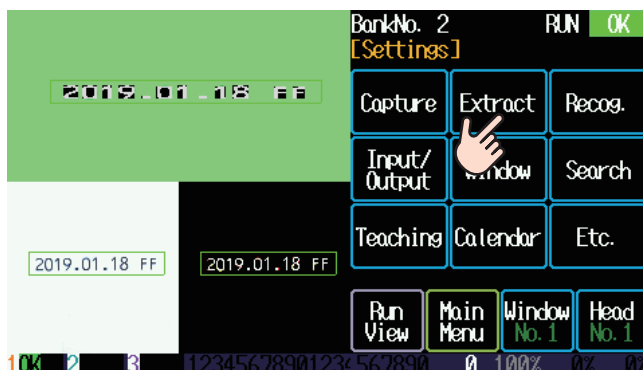

## 6-4-1 Character Cutout Settings

This section explains how to configure the settings for character cutout.

- 1 On the [2 Extract] screen, touch [Extract].

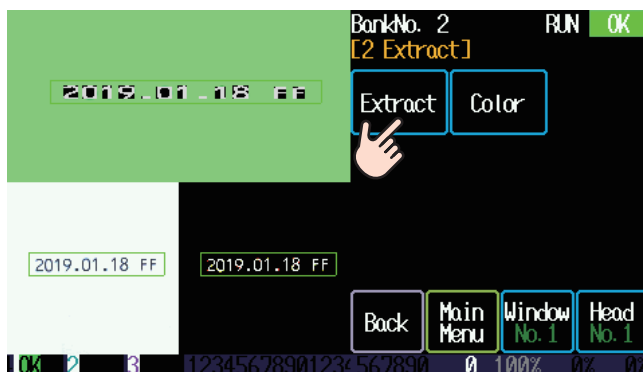

- 2 Select an item.



The settings and their corresponding details are shown below.

Setting item	Setting details	Setting value (Values in bold are default values.)	Applies to
Cutout Level*	Set the threshold for character extraction in the inspection window. A small value enables you to extract low-density characters, but can increase the level of noise.	0 to <b>15</b> to 31	Window
Bolding*	Set whether to make the extracted characters bold or narrow. For bold fonts, specify a small value. For narrow or dot characters, specify a large value.	-3 to <b>0</b> to 16	Window
Char. Width*	Set the standard width to use for extracting characters one character at a time.	0 to <b>16</b> to 500	Window
Char. Height*	Set the standard height to use for extracting characters one character at a time.	0 to <b>24</b> to 500	Window
Min. Width*	Set the minimum character width to use for extracting characters one character at a time. Characters whose widths are less than or equal to this value will not be cut out.	<b>0</b> to 200	Window
Min. Height*	Set the minimum character height to use for extracting characters one character at a time. Characters whose heights are less than or equal to this value will not be cut out.	<b>0</b> to 200	Window
Height Limit*	Alphanumeric characters (0 to 9 and A to Z) whose heights are less than this value will not be cut out.	0 to <b>10</b> to 200	Window
Stamp	Configure this setting to emphasize the upper and lower parts of characters. This setting is useful when the upper and lower parts of the characters can become blurry, such as for stamp characters. "Normal:" The upper and lower parts of characters will not be emphasized. "Stamp:" The upper and lower parts of characters will be emphasized.	<b>Normal</b> , Stamp	Window
Bg. Filter	Configure this setting when the inspection window includes background patterns that are not part of the inspection characters. The filter effect setting has three levels: "25%," "50%," and "70%."	<b>Off</b> , 25%, 50%, 70%	Window
Rotation Offset	Set the initial angle prior to rotation correction. Use this setting value when the camera unit has been attached at an angle.	-90 to <b>Off</b> to 90 (°)	Bank
Rotation Correction	Set to correct the rotation angle of the characters for each inspection window. The larger the value, the longer the processing time.	<b>Off</b> , ±0.45, ±0.9, ±1.3, ±1.8, ±2.2, ±2.7, ±3.1, ±3.6, ±4.5, ±5.4, ±6.2, ±7.1, ±8.4, ±10.2, ±12.0, ±14.0 (°)	Window
Slant Offset	Set the angle to use to correct slanted characters. Configure this setting when the characters are slanted at a fixed angle.	-26, -24, -22, -20, -19, -17, -15, -14, -12, -10, -8.5, -6.8, -5.1, -3.4, -1.7, <b>0</b> , 1.7, 3.4, 5.1, 6.8, 8.5, 10, 12, 14, 15, 17, 19, 20, 22, 24, 26	Window

Setting item	Setting details	Setting value (Values in bold are default values.)	Applies to
Slant Correction	Set to correct characters that are not slanted at a fixed angle for each inspection. The larger the value, the longer the processing time.	<b>Off</b> , ±0.9, ±1.7, ±2.6, ±3.4, ±4.3, ±5.1, ±6.0, ±6.8, ±7.7, ±8.5, ±9.4, ±10.2, ±11.1, ±11.9, ±12.8, ±13.6, ±14.5, ±15.3, ±16.2, ±17.0 (°)	Window
Slant Retry	If the judgement result is NG, slant the characters to a set angle, and perform the measurement again. This setting is useful when character recognition is poor.	Off, ±0.9, ±2.6, <b>±4.3</b> , ±6.0, ±8.5 (°)	Window
Split X Char.	Use this setting to force characters that are adjacent to each other to split horizontally.	Off, Line 1, Line 2, <b>All</b>	Window
Split Y Line	Use this setting to force characters that are adjacent to each other to split vertically.	Off, <b>On</b>	Window
X Dot Period	Specify the dot interval in the horizontal direction. Use this setting when characters cannot be cut out due to large spaces between the dots.	<b>0</b> to 15	Bank
Y Dot Period	Specify the dot interval in the vertical direction. Use this setting when characters cannot be cut out due to large spaces between the dots.	<b>0</b> to 15	Bank

\* When you perform teaching, this setting value is changed automatically.

## 6-4-2 Color Extraction

This section explains how to configure the settings for color extraction.

When you perform color extraction, you can extract the character color even when the background of the inspection characters has a color or colored pattern.

To extract colors with the manual settings, set the inspection window to "Window On" (see "6-7 The Inspection Window" (page 6-57)), and then follow the procedure shown below.

- 1 On the [2 Extract] screen, touch [Color].

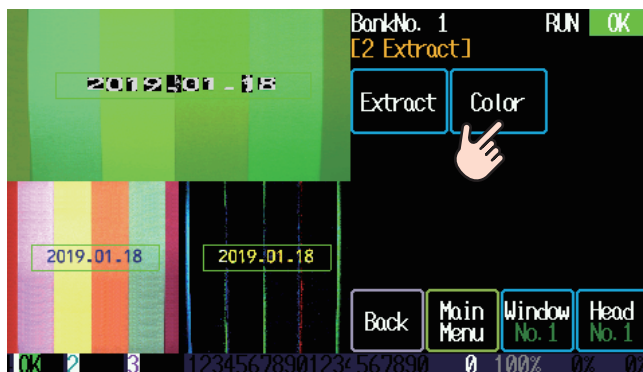

In the camera image display, the raw image is displayed in the upper part and the processed image is displayed in the lower part.

- 2 Touch [Color Off] to change the key to [Color On].

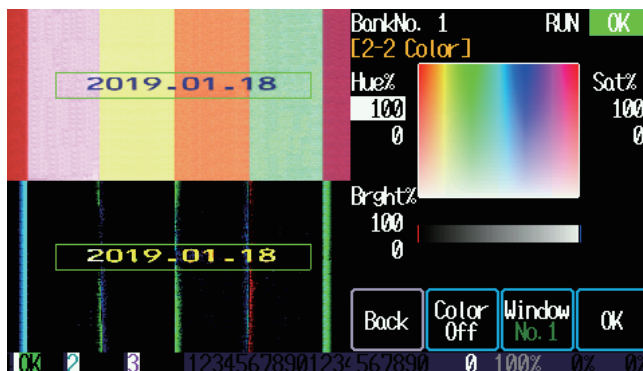

- 3 Touch the color bars to select a color that is close to the color of the characters.

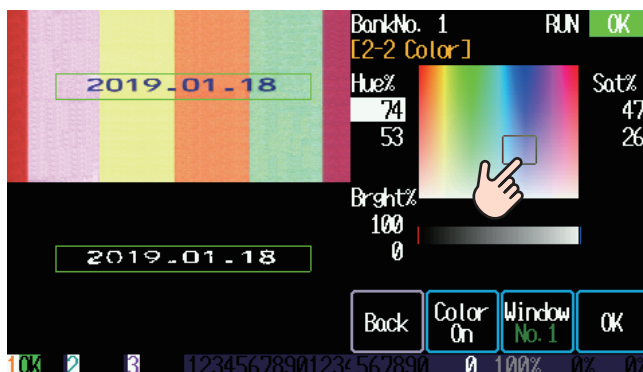
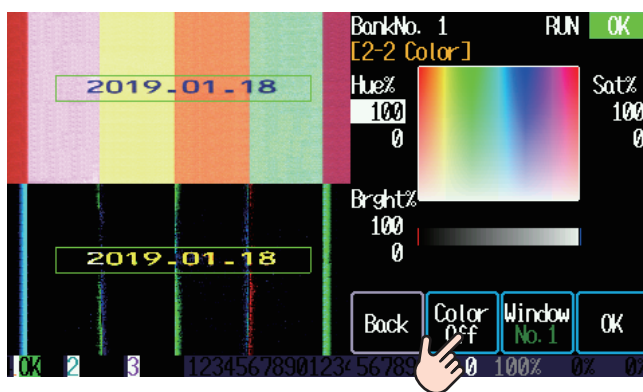

- 4** Touch the screen or use the **Y2** and **A8** keys to specify the item that you want to set, and then press the **SET** key.

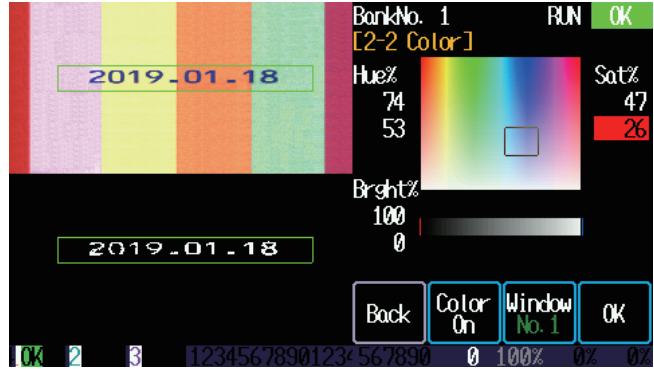

- 5** Use the **Y2** and **A8** keys to adjust the setting value.  
The characters set as the target for color extraction are displayed in white in the lower part.  
Adjust the setting value until the white characters are displayed clearly.

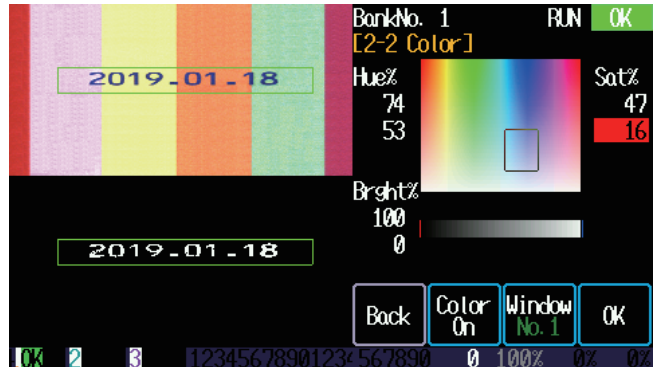

- 6** Press the **SET** key.  
The setting value is confirmed.

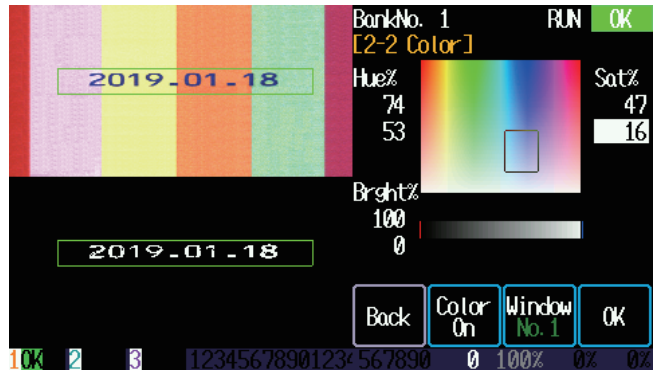

- 7** Touch [OK].

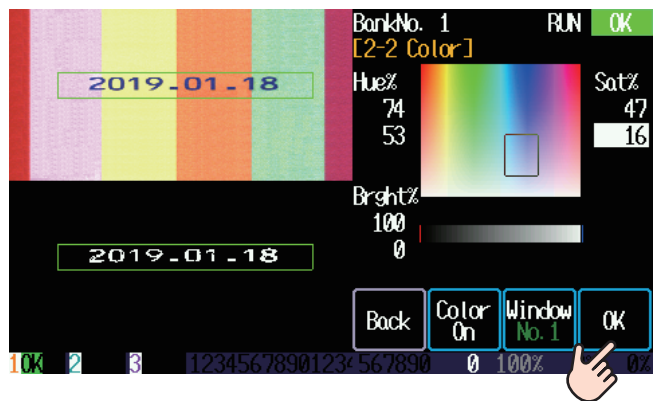

# 6-5 Character Recognition Settings

This section explains how to configure the settings for the state of the read characters.

- 1 On the [Settings] screen, touch [Recog.].

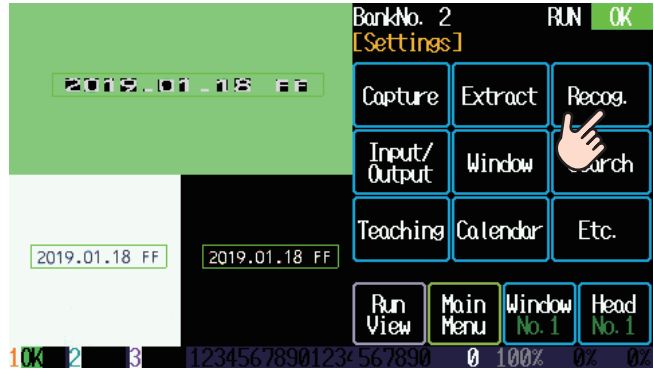

## 6-5-1 Configuring Character Recognition Settings

Configure the settings for character recognition.

- 1 On the [3 Recog.] screen, touch [Recog.].



- 2 Select a setting.



The settings and their corresponding values are shown below.

Settings	Details	Values (Values in bold are default values.)	Applies to
Format#1*	Set the data format for format 1, such as dates, times, and character strings. When you set a date format, the format will be linked to the built-in calendar timer.	<b>Off</b> ; YYYYMD; YYYYM; YYMD; YYM; MD; String; Command; Alph. MD; Alph. M; Alph. D; Alph. HM; Alph. Min; YYYYED; YYYYE; YYED; YYE; 1Y; HH:MM; HH; HHMM; Alph. H+M	<input type="button" value="Window"/>
Format#2*	Set the data format for format 2, such as dates, times, and character strings. When you set a date format, the format will be linked to the built-in calendar timer.		<input type="button" value="Window"/>
Format#3*	Set the data format for format 3, such as dates, times, and character strings. When you set a date format, the format will be linked to the built-in calendar timer.		<input type="button" value="Window"/>
Format#4*	Set the data format for format 4, such as dates, times, and character strings. When you set a date format, the format will be linked to the built-in calendar timer.		<input type="button" value="Window"/>
Dot Checking*	Use this setting to check for dots between dates. "On": Check for dots between dates. "Off": Do not check for dots between dates. The judgement result will be OK even when there are no dots between dates.	<b>Off, On</b>	<input type="button" value="Window"/>
Date Order	Set the date order. "Y-M-D": Dates are recognized in the order of year, month, day. "M-D-Y": Dates are recognized in the order of month, day, year. "D-M-Y": Dates are recognized in the order of day, month, year.	<b>Y-M-D</b> ; M-D-Y; D-M-Y	<input type="button" value="Bank"/>
Re-Scanning	When judgment is NG, skip over a set number of characters and then perform the judgment again. "NextLine": Perform Judgment again starting from the characters on the next line. "1 Char.": Perform Judgment again while skipping one character at a time. "1 Line": Perform Judgment again one character at a time. If the next line is reached, the judgment will be NG.	<b>Off, NextLine, 1 Char., 1 Line</b>	<input type="button" value="Bank"/>
Check Line Feed	Set to recognize line feeds as character delimiters. If you set this to "On" and [Dot Checking] is also "On," the judgment will be NG if no line feeds or dots are present.	<b>Off, On</b>	<input type="button" value="Window"/>
Insert Line Feed	If the space from the right edge of a character to the left edge of the next character is greater than or equal to the character width × this setting value, a line feed will be inserted automatically.	<b>Off</b> , ×0.5, ×1.0, ×1.5, ×2.0, ×2.5, ×3.0, ×3.5, ×4.0, ×4.5, ×5.0, ×5.5, ×6.0	<input type="button" value="Window"/>
Month 0 Padding	Set to check for a leading "0" in single digit months. For example, if set to "On," July will be judged OK if the value is "07," but NG if the value is "7."	<b>Off, On</b>	<input type="button" value="Window"/>
Day 0 Padding	Set to check for a leading "0" in single digit days. For example, if set to "On," the seventh day of the month will be judged OK if the value is "07," but NG if the value is "7."	<b>Off, On</b>	<input type="button" value="Window"/>

Settings	Details	Values (Values in bold are default values.)	Applies to
Hour 0 Padding	Set to check for a leading "0" in single digit hours. For example, if set to "On," 7 o'clock will be judged OK if the value is "07," but NG if the value is "7."	<b>Off</b> , On	Window
Min. 0 Padding	Set to check for a leading "0" in single digit minutes. For example, if set to "On," 7 minutes will be judged OK if the value is "07," but NG if the value is "7."	<b>Off</b> , On	Window
0 Suppress	Set to check for a leading "0" for years, months, days, hours, and minutes that have only a single digit. For example, if set to "On," 7 minutes will be judged OK if the value is "7," but NG if the value is "07." This setting will have priority if its value disagrees with the [Month 0 Padding], [Day 0 Padding], [Hour 0 Padding], or [Min. 0 Padding] settings.	<b>Off</b> , On	Window
Vertical Printing	Set to read date formats with a vertical year, month, and day.	<b>Off</b> , On	Window
String Lines	Set the number of character string lines to recognize as a character string format. For example, if set to "1," one line will be recognized per format.	0, <b>1</b> , or 2	Window
Month Abbrev.	Set the number of characters to check for written names of months (such as January and February). For example, for three characters, set to "SEP," and for six characters, set to "SEPTEMBER."	<b>SEP</b> , SEPT, SEPTE, SEPTEN, SEPTEMB, SEPTEMBER, Full	Window
No. of Month Table	Set the number of characters of the month decryption table.	<b>1 Char.</b> , 2 Char.	Bank
No. of Day Table	Set the number of characters of the day decryption table.	<b>2 Char.</b> , 1 Char.	Bank
Era Year	Set to subtract when converting a Japanese era year to a year in the western calendar (the last two digits). For example, to convert from the Heisei era to the western calendar, set this value to "12." (Heisei 26 - 14 [for 2014] = 12)	-100 to <b>0</b> to 100	Window
Allow :	Set to handle colons (":") as dots when checking for dots.	<b>Off</b> , On	Window
Allow /	Set to handle slash marks ("/") as dots when checking for dots.	<b>Off</b> , On	Window
Allow ..	When [Dot Checking] is "On," the judgment result will be OK also when the dot part is ".." with foreign materials and noise cut out.	<b>Off</b> , On	Window
Char. Count	Set whether to include question mark characters ("?") in the judgment of the number of characters. "?Include:" Question mark characters ("?") will be included in the judgment of the number of characters. Question mark characters ("?") will be excluded from the count of the number of characters for both numeric values and alphabet characters. "?NoCount:" Question mark characters ("?") will not be included in the judgment of the number of characters.	?Include, <b>?NoCount</b>	Window

Settings	Details	Values (Values in bold are default values.)	Applies to
Max. String Length	Set the maximum number of characters that will be judged as an OK in the inspection window. If the number of characters in the recognized string exceeds the value set here, the judgment will result in a failure.	0 to <b>60</b>	<input type="text" value="Window"/>
Min. String Length	Set the minimum number of characters that will be judged as an OK in the inspection window. If the number of characters in the recognized string is less than the value set here, the judgment will result in a failure.	<b>0</b> to 60	<input type="text" value="Window"/>
Global Match Level	Use this setting value to display data that is not read as actual characters as question mark characters ("?") in the recognition results and match rates display. This happens when the match level between the recognized characters and the built-in dictionary is less than this setting value.	0 to <b>70</b> to 100	<input type="text" value="Window"/>
Judgment Polarity	Use this setting value to invert the judgment results for each inspection window. "Normal": The result will be an OK judgment if the character is within the setting range. "Invert": The result will be an NG judgment if the character is within the setting range. (This would normally result in an OK judgment.)	<b>Normal</b> , Invert	<input type="text" value="Window"/>
Built-in Dict.	Set whether to use the built-in dictionary during character recognition. "Off": Only the dictionaries set with the extended dictionary will be used during character recognition. "On": The built-in dictionary and the dictionaries set with the extended dictionary will be used during character recognition.	Off, <b>On</b>	<input type="text" value="Bank"/>
Extended Dict.	Select the extended dictionary group to use. You can set this value to an independent dictionary group or to a combination of dictionary groups.	Off, <b>1</b> , <b>2</b> , <b>1 + 2</b> , <b>3</b> , <b>1 + 3</b> , <b>2 + 3</b> , <b>1 + 2 + 3</b>	<input type="text" value="Bank"/>
No. of Dict#1	Specify the number of dictionaries to use in dictionary group 1.	<b>0</b> to 500	<input type="text" value="All banks"/>
No. of Dict#2	Set the number of dictionaries in dictionary group 2.	<b>0</b> to 500	<input type="text" value="All banks"/>
No. of Dict#3	Set the number of dictionaries in dictionary group 3.	<b>0</b> to 500	<input type="text" value="All banks"/>
Auto Dictionary	Set to automatically register characters with OK judgments and low match rates in the extended dictionary. Before you set this value, set [Extended Dict.] to the dictionary group that you will use.	<b>Off</b> , Group#1, Group#2, Group#3	<input type="text" value="All banks"/>
Auto Dict. Level	Set to automatically register characters with OK judgments and match rates less than the set value in the extended dictionary.	0 to <b>80</b> to 99	<input type="text" value="All banks"/>

\* When you perform teaching, this setting value is changed automatically.

## MEMO

When you set [Auto Dictionary] to a value other than "Off," allow some characters to be registered, and then, after reading has stabilized, set this to "Off."

## ■ Unique date

You can create formats that are not included in the existing formats by replacing character strings with the commands in the following table.

Command	Details
_ (underscore character)	One character string is separated from another. When the analysis of one recognized character string finishes, the device will move on to the the next format. The same process is also performed for the String format.
?	The judgment result is OK if any single character is present. The same process is performed for the String format.
i	The judgment result is OK if the recognized character string is a "." (a dot). The judgment result is NG if there is no dot. This command is ignored when [Dot Checking] is set to "Off." If [Allow :] within the [Recog.] settings is set to "On," the judgment result is also OK even if a ":" is present. If [Allow /] is set to "On," the judgment result is also OK even if a "/" is present. If [Allow ..] is set to "On," the judgment result is also OK even if a ".." is present.
e	The recognized character string is interpreted as a 2-digit numeric value, and the judgment result is OK for the characters "28" and "30."
b	The recognized character string is interpreted as a 2-digit numeric value, and the judgment result is OK for the last day of the month.
f	The recognized character string is interpreted as a 4-digit year.
z	The recognized character string is interpreted as a 2-digit year.
y	The recognized character string is interpreted as a 1-digit year. The judgment result is OK if the recognized string matches the lowest digit of the year according to the western calendar.
n	The recognized character string is interpreted as a 2-digit month.
c	The recognized character string is interpreted as a 2-digit day.
g	The recognized character string is interpreted as a 2-digit hour value.
p	The recognized character string is interpreted as a 2-digit minute value.
m	The recognized string is interpreted as a 1-digit month according to the decryption table. The same process is performed for the Month format.
d	The recognized string is interpreted as a 2-digit day according to the decryption table.
h	The recognized string is interpreted as a 1-digit hour according to the decryption table. In this case, upper/lower limit of the [Time Offset#1] and [Time Offset#2] are enabled.
q	The recognized string is interpreted as a 1-digit minute according to the decryption table.
u	The recognized string is interpreted as a 1-digit year according to the decryption table. For the year 20XY, X is the year from the judged date and Y is from the decryption table.
v	The recognized string is interpreted as a 1-digit year (the tens position) according to the decryption table. For the year 20YX, X is the year from the judged date and Y is from the decryption table. In combination with command u, this enables a 2-digit year form.
r	The recognized string is interpreted as the written name of a month.
t	The recognized string is interpreted as a 1-digit or 2-digit year. If a match is not obtained by reading the string as a 1-digit year, the string is read as a 2-digit year.
s	The recognized string is interpreted as a 3-digit serial date. The year is interpreted according to the most recently interpreted year (example: "y," "z," or YYYYMD).
a	The judgment result is OK if the characters match according to the alphabet and time group.

Command	Details
{	Check for line feed characters. The same process is performed for the String format.
;	The judgment result is OK if a single arbitrary numeric character is present. The same process is performed for the String format.
\	The judgment result is OK if a single arbitrary alphabet character is present. The same process is performed for the String format.
A value other than those listed above	The judgment result is OK if the specified character and the recognized character match.

## MEMO

- In ASCII code, the yen character becomes a backslash (\).

### Caution

You can only set up to two offsets and two tolerances for the date and time in a single inspection window. Note this point when creating the format.

## 6-5-2 Date Settings

Configure the settings related to the date.

- On the [3 Recog.] screen, touch [Date].

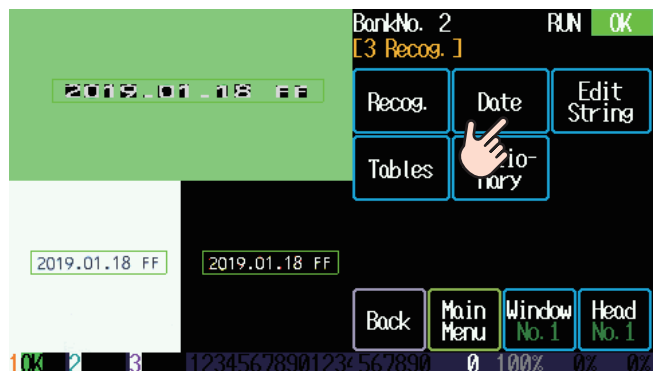

- Select a setting.



The settings and their corresponding details are shown below.

Setting	Details	Value (Values in bold are default values.)	Applies to
Date Offset#1*	Set to add a value to the date of the calendar timer. The resulting date is used as the reference for date judgment. For formats that have days (for example, YYYYMD), the unit is days. For formats that do not have days (for example, YYYYM), the unit is months. This setting is enabled on the first date format.	-30000 to <b>0</b> to 30000	<input type="button" value="Window"/>
Date Tolerance#1*	Set the margin of days to allow when performing date judgment. For example, if you set this to "1," the day can be off by 1 day in either the positive or negative direction in relation to the reference date. This setting is enabled on the first date format.	<b>0</b> to 1000 (days)	<input type="button" value="Window"/>
Time Offset#1*	When performing time judgment, this value is added to the time of the calendar timer. The resulting time is used as the reference for time judgment. If the value exceeds 24 hours, the reference date will increase by 1 day. This setting is enabled on the first date format.	-4320 to <b>0</b> to 4320 (minutes)	<input type="button" value="Window"/>
Time Tolerance#1	Set the margin of minutes to allow when performing time judgment. For example, if you set this to "30," the time can be off by 30 minutes in either the positive or negative direction in relation to the reference time. This setting is enabled on the first date format.	0 to <b>30</b> to 1000 (minutes)	<input type="button" value="Window"/>
Date Offset#2*	When performing date judgment, this value is added to the date of the calendar timer. The resulting date is used as the reference date. For formats that have days (for example, YYYYMD), the unit is days. For formats that do not have days (for example, YYYYM), the unit is months. This setting is enabled on the second date format.	-30000 to <b>0</b> to 30000	<input type="button" value="Window"/>
Date Tolerance#2*	Set the margin of days to allow when performing date judgment. For example, if you set this to "1," the day can be off by 1 day in either the positive or negative direction in relation to the reference date. This setting is enabled on the second date format.	<b>0</b> to 1000 (days)	<input type="button" value="Window"/>
Time Offset#2*	When performing time judgment, this value is added to the time of the calendar timer. The resulting time is used as the time reference. If the value exceeds 24 hours, the reference date will increase by 1 day. This setting is enabled on the second date format.	-4320 to <b>0</b> to 4320 (minutes)	<input type="button" value="Window"/>
Time Tolerance#2	Set the margin of minutes to allow when performing time judgment. For example, if you set this to "30," the time can be off by 30 minutes in either the positive or negative direction in relation to the reference time. This setting is enabled on the second date format.	0 to <b>30</b> to 1000 (minutes)	<input type="button" value="Window"/>

Setting	Details	Value (Values in bold are default values.)	Applies to
Force Per Month	When you have specified a date format that includes days such as YYYYMD, use this setting value to change the date offset to units of months. The current day is used to determine the upper and lower limit dates. However, if the determined days do not exist in the corresponding month, the days are changed to valid values (28 or 30).	<b>Off</b> , Date1, Date2, Date1,2	<input type="text" value="Window"/>
Allow Leap Year	If you have set a value for [Force Per Month], the judgment result OK if the upper or lower limit date is February 29 and the year is a leap year. If you set this to "Off," February 29 will be changed to February 28 even if it is a leap year.	<b>Off</b> , On	<input type="text" value="Window"/>
CalendarOffset	Offset the updating of the judged date just by the time specified from the time of the calendar timer. Use this when you want to set the updating of the date to a time other than 00:00.	-4320 to <b>0</b> to 4320 (minutes)	<input type="text" value="Bank"/>
Date Retry	When Dot Checking is set to On, retry the date of the final digit. With Dot Checking set to Off, use this setting if you want the judgment result to be NG for the text "2018.4.11" when inspecting for "2018.4.1." With Dot Checking set to On, use this setting if you do not want to read "2018.4.1 OF" as "2018.4.10."	<b>Off</b> , On	<input type="text" value="Bank"/>
Offsetting Dates	When selecting a date format that includes only the year and month, such as YY-YYM, using the calendar offset or time offset setting makes it possible to specify an exact date.	<b>Off</b> , On	<input type="text" value="Bank"/>

\* When you perform teaching, this setting value is changed automatically.

## 6-5-3 Edit Character Strings

Edit the read character string.

- 1 On the [3 Recog.] screen, touch [Edit String].

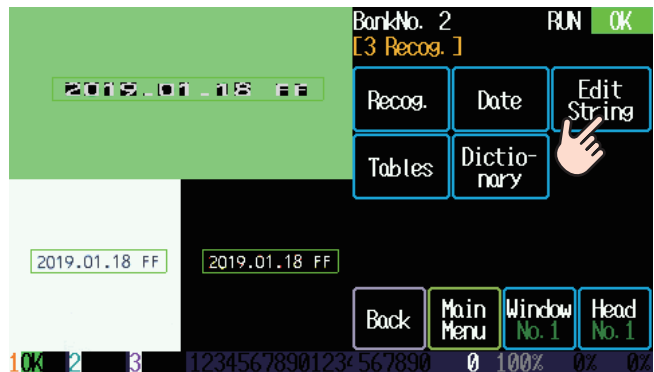

- 2 Touch [A/1] to switch between the key displays and enter the character string. You can enter up to 30 characters.

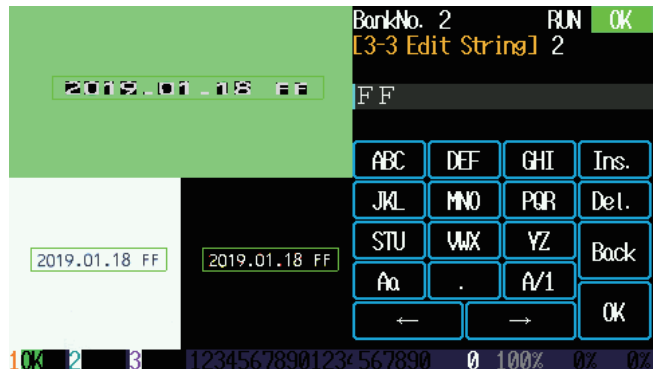

### MEMO

When editing a character string, press the [0] key on the controller to perform the following operations.

<b>When the character string is recognized</b>	The recognized character string is displayed in the editing window. * The judgment of the numeric values and alphabet characters in the displayed character string depends on the set characters.
<b>When the character string is not recognized</b>	The recognition result is displayed in the editing window as numeric values.

## MEMO

### Switching the key display

Each time you touch [A/1], the key display switches between numeric values and uppercase letters. When uppercase letters are displayed, touch [Aa] to switch the key display to lowercase letters.



## Input method

When you touch an alphabet key once, the first character on the key is entered. If you repeatedly touch the same key, each touch changes the character that is entered as shown below.

- If you touch [ABC]: A, B, C, A, etc.
- If you touch [abc]: a, b, c, a, etc.

The roles of the other keys are shown below.

Key	Setting details
.	Touch this key to enter a symbol at the cursor position. When you touch this key once, a period ("."), which is the first symbol, is entered. If you repeatedly touch this key, the symbol is changed in the order shown shown below. ., /, :, _ , ^ , ? , ↓ , ; , \ , ! , # , \$ , % , & , ( , ) , * , + , - , < , = , > , @ , [ , ] , "
Ins./Ovwt	Ins.: Touch this key to insert the entered character at the cursor position. Ovwt: Touch this key to overwrite the character at the cursor position with the entered character.
Del.	If the cursor is at the end of the string, touch this key to delete the character in front of the cursor. If the cursor is in any other position, touch this key to delete the character at the cursor position.
Back	Touch this key to discard the changes you have made to the character string and return to the previous screen.
OK	Touch this key to save the edited character string and return to the previous screen.
←	Touch this key to move the cursor position one character to the left.
→	Touch this key to move the cursor position one character to the right.

## 3 Touch [OK].

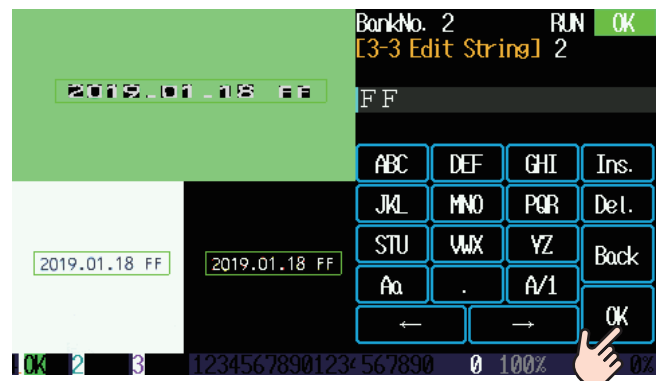

## 6-5-4 Simple String Editing

Use simple string editing to edit the read character string.

### MEMO

To enable simple string editing, set "Easy String Edit" to "On" in the [Etc.] settings. (See "6-11 Other Settings" (page 6-69).)

#### Input example: Entering "FF" into the read character string

- 1 On the [Edit String] screen, use the [▲] and [▼] keys to select "F."

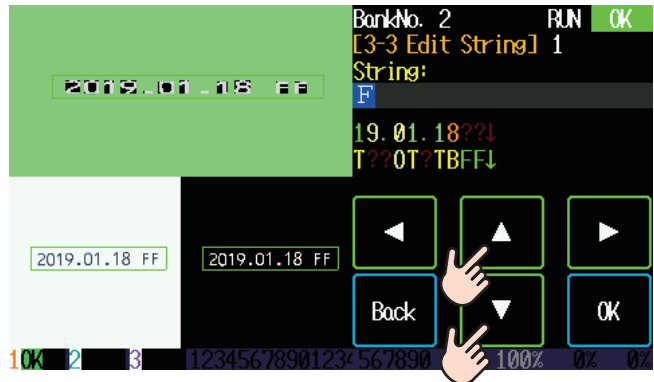

- 2 Touch [▶] to move the cursor position to the right.

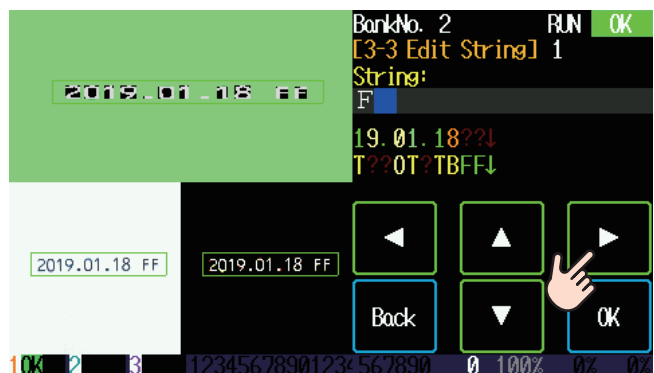

- 3 Use the [▲] and [▼] keys to select "F."

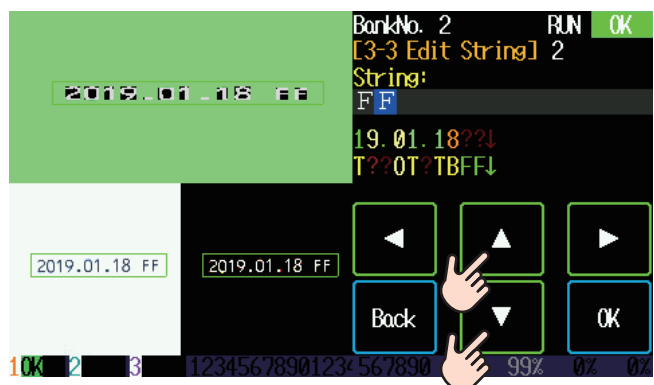

## MEMO

### Input method

Each time that you touch [▲] or [▼], the character to edit from the read characters changes. The roles of the other keys are shown below.

Key	Setting details
◀	Touch this key to move the cursor position one character to the left.
▶	Touch this key to move the cursor position one character to the right.
	Press this key to delete the character at the cursor position. If no character is present at the cursor position, nothing is deleted.
Back	Touch this key to discard the changes you have made to the character string and return to the previous screen.
OK	Touch this key to save the edited character string and return to the previous screen.

### 4 Touch [OK].

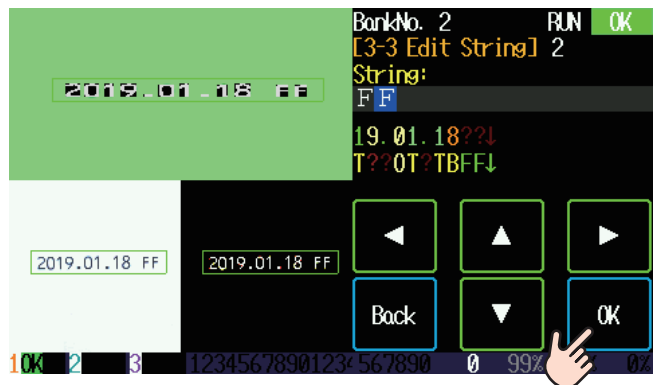

## 6-5-5 Decryption Table and Strictness Settings

Configure the settings of the decryption tables used to convert to normal numeric values dates that have been encrypted to alphabet characters. Configure settings of the strictness table that determines the lower limits of the strictness levels for character matching.

### ■ Configure decryption table settings

When the inspection target is a date and the month, day, hour, minute, or time slot has been encrypted to a numeric value, alphabet character, or symbol, the encrypted value will be converted to the normal month, day, hour minute, or time slot.

The conversion tables used in this process are called "decryption tables."

### ● Decryption table example

This section provides examples of decryption tables and the settings on the device.

Examples of year, month, day, hour, and minute encryption are shown below.

#### Year example

The lower one digit of the year according to the western calendar is displayed using alphabet characters.

Year (lower one digit)	Decryption table value
20x0	A
20x1	B
~	~
20x8	I
20x9	J

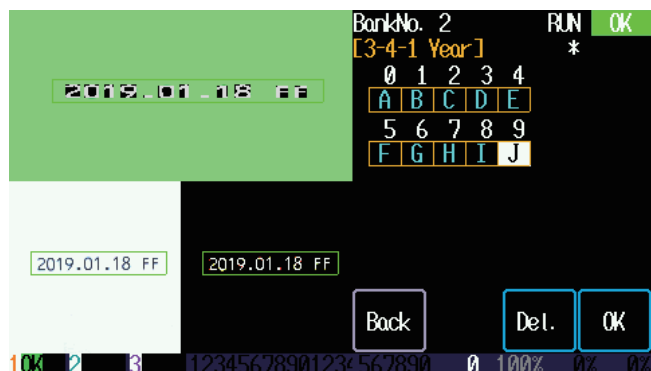

Example of settings on the device

#### Month example

The month of the date is displayed with numeric values and alphabet characters.

Month	Decryption table value
January	01
February	02
~	~
November	0B
December	0C

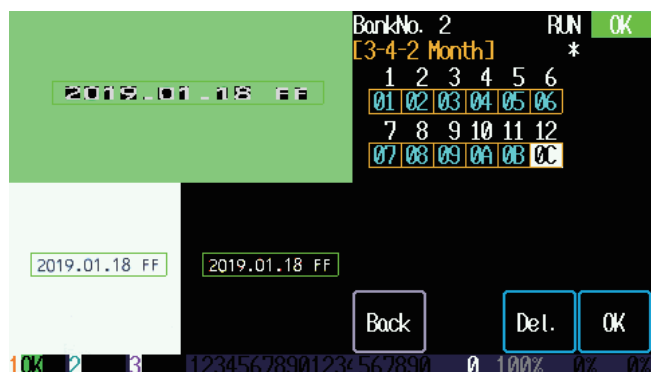

Example of settings on the device

### ●●● MEMO ●●●

You can change whether the month decryption table is set with a single character or with two characters. (See [No. of Month Table] and [No. of Day Table] in "6-5-1 Configuring Character Recognition Settings" (page 6-23).)

### Day example

The day of the date is displayed with alphabet characters and numeric values.

Day	Decryption table value
1	A1
~	~
9	A9
10	B0
~	~
19	B9
20	C0
~	~
29	C9
30	D0
31	D1



Example of settings on the device

### Hour example

The hour value of the time is displayed with one alphabet character.

Hour	Decryption table value
00:00	A
01:00	B
~	~
12:00	M
~	~
23:00	X

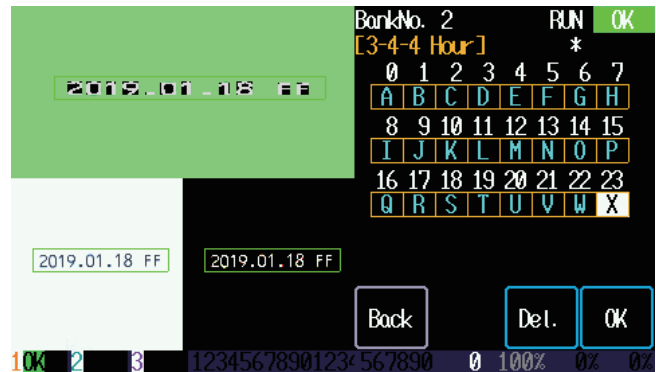

Example of settings on the device

### Minute example

The minute value of the time is displayed with one alphabet character per 10 minutes.

Minute	Decryption table value
0	A
1	A
~	~
9	A
10	B
~	~
19	B
20	C
~	~
29	C
30	D
~	~
39	D
40	E
~	~
49	E
50	F
~	~
59	F

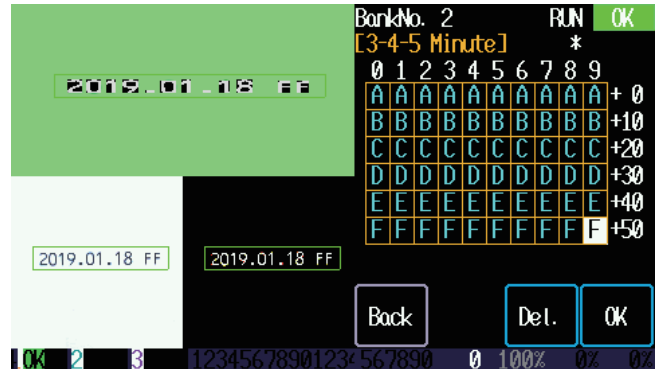

Example of settings on the device

### Time group example

This supports encryption into time slots, such as for work shifts.

The following is an example of a three-work-shift system expressed with alphabet characters.

Start time	End time	Time group value
06:00	13:59	A
14:00	21:59	B
22:00	05:59	C

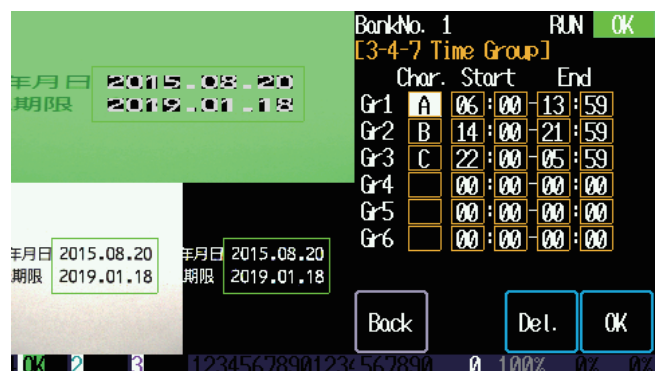

Example of settings on the device

## ● Configure settings

This section explains the setting method by setting [Month] as an example.

- 1 On the [3 Recog.] screen, touch [Tables].

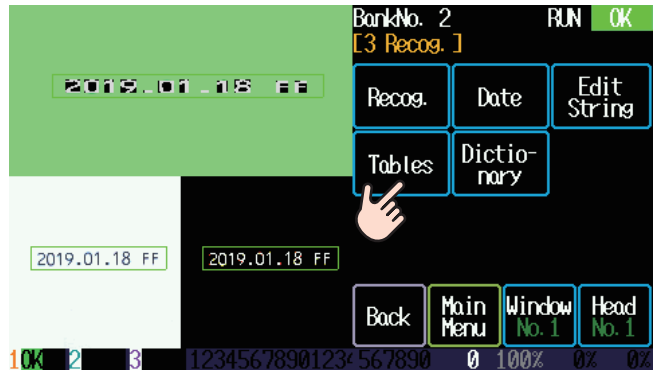

- 2 Touch [Year], [Month], [Day], [Hour], [Minute], or time group depending on the decryption table that you want to set.

Touch [Month].

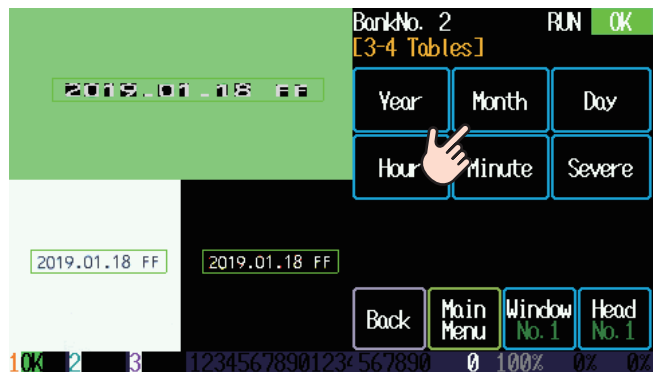

- 3 Move the cursor to the input field that you want to set in the table, and then press the **SET** key.

Use the decryption table shown above as an example to enter the "Month" table values using numeric values and alphabet characters starting from January.

If two digits are being used to enter the value, enter the higher-order digit first.

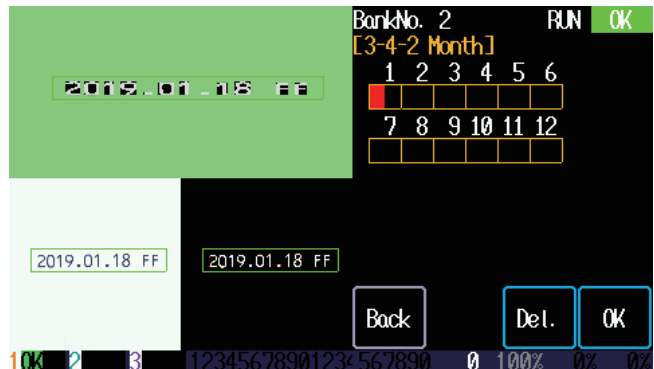

**4** Use the **↵** and **⏏** keys to select the encrypted character, and then press the **SET** key.

The value in the decryption table example for January is "01," so enter a "0" as the first digit.

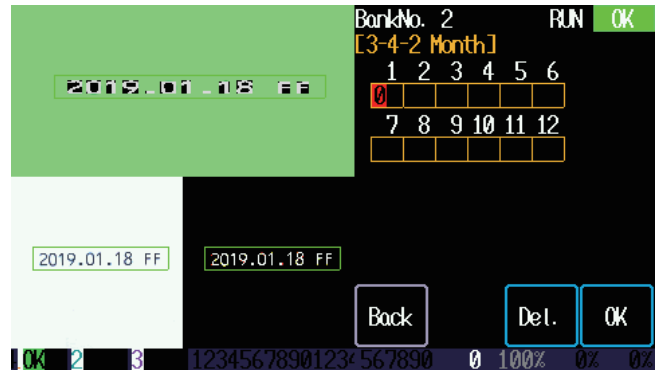

The input is entered and the cursor moves to the next character.

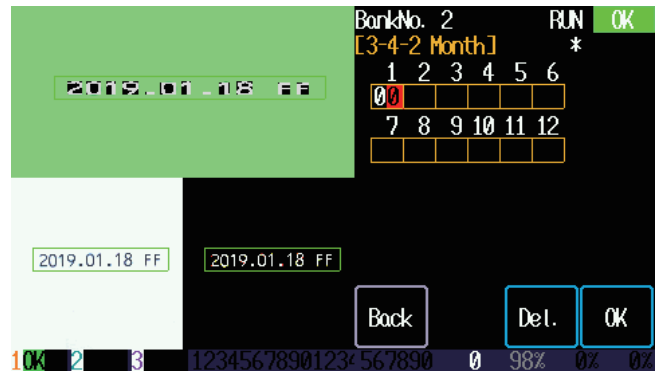

Continue by entering the next character. The value in the decryption table example for January is "01," so enter a "1" as the second digit.

In the same way, enter the values for all the months up to December.

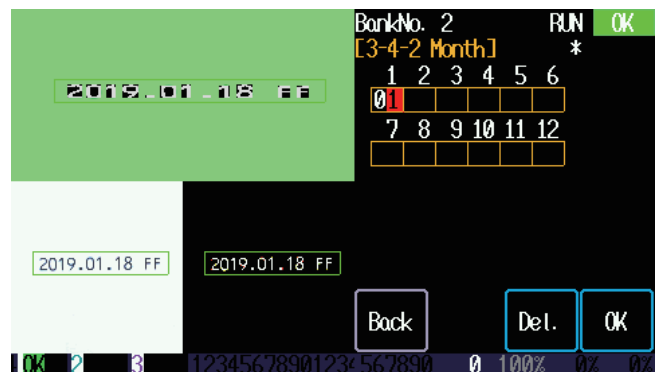

**MEMO**

- The same character is entered each time that you press the **SET** key.
- To correct a character that you have already entered, press the **EXIT** key, move the cursor to the character that you want to correct, and then press the **SET** key.
- For the month decryption table/day decryption table, use [No. of Month Table]/[No. of Day Table] to set the number of characters used in each table to one character or two characters. Access this setting by touching [Settings] and then [Recog.].
- Characters that have already been set are displayed in blue.

**5** Touch **[OK]**.

After you have entered the values for January to December, the [Month] decryption table will appear as shown in the screen on the right.

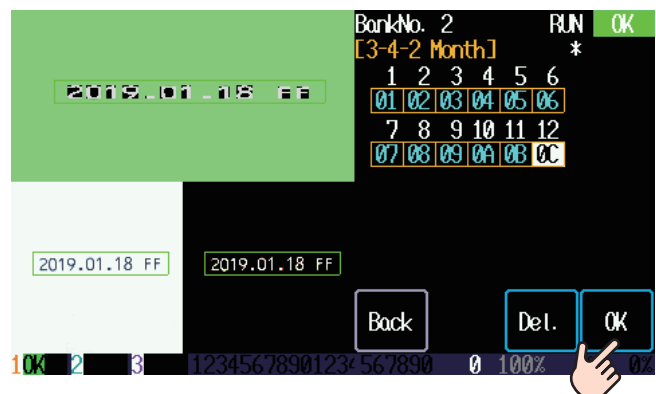

## Strictness table settings

Set the strictness table that determines the lower limit of the strictness for each character.

If the inspection character has a value that is less than or equal to the strictness set here, the judgment result will be NG.

- 1 On the [3 Recog.] screen, touch [Tables].

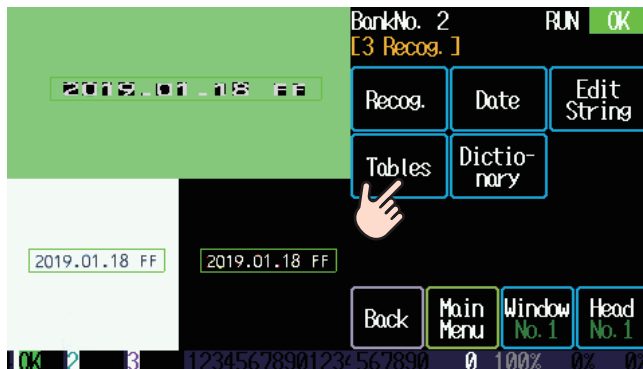

- 2 Touch [Severe].



- 3 Move the cursor to the character whose strictness you want to set, and then press the **SET** key.



- 4** Use the **▼2** and **▲8** keys to set the strictness, and then press the **SET** key.



The input is entered and the cursor moves to the next strictness value.



- 5** To configure the setting for a different character, press the **EXIT** key and then move the cursor.



## MEMO

Strictness values that have already been set are displayed in blue.

- 6** Touch [OK].

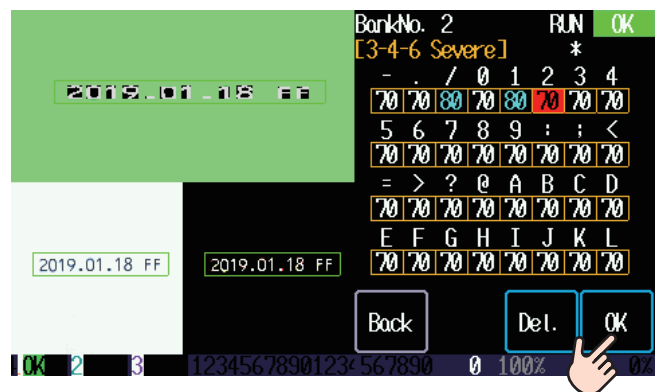

## 6-5-6 Extended Dictionary Settings

In addition to the camera unit's built-in dictionary, you can configure the extended dictionary settings.

The camera unit may not be able to read characters correctly due to the state of workpieces or the print quality or due to the type of character font.

In these cases, you can stop the camera unit from recognizing characters incorrectly by registering in the dictionary the characters that the camera unit reads incorrectly. This will enable the camera unit to read these characters correctly.

You can register up to 3 groups in the extended dictionary. Up to 500 characters can be registered in each group, allowing you to register a total of 1500 characters.

- 1 On the [3 Recog.] screen, touch [Dictionary].

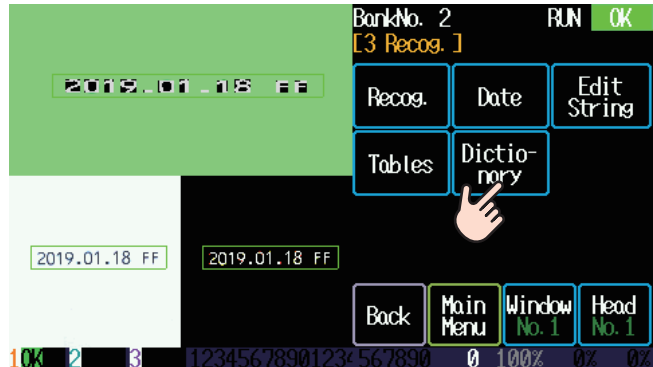







- 2 Select the dictionary group in which you want to register the character.



### MEMO





- To the right of each dictionary group name, the number of characters that are currently registered in the group are displayed.
- You can change each dictionary group name to any name. Touch [Edit] to display the [Edit Group Name] screen, and then change the name.
- To delete a dictionary group, select the dictionary group, and then touch [Del.].

- 3** Touch a new or existing dictionary entry number or use the , ,  , and  keys to select the dictionary entry number, and then touch [OK]. In step 4, you can move the cursor to [Dict#], and then use the  and  keys to select the dictionary entry number.



**MEMO**

Touch [Sort] to switch the way that the registered characters are sorted from numeric order to alphabetical order.

- 4** Use the  and  keys to move the cursor to [Position], and then use the  and  keys to select the position of the character for which you will create the dictionary entry.

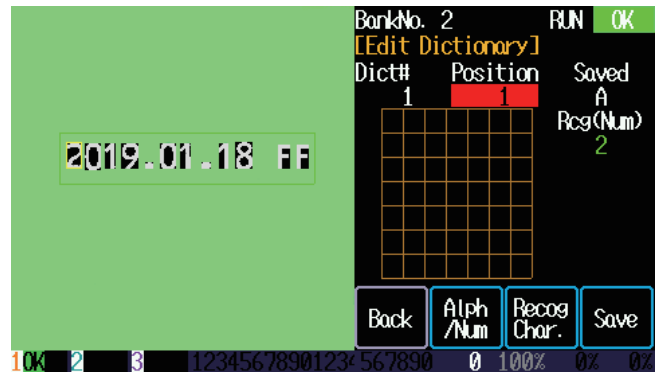





In the inspection image, the character at the selected character position is highlighted in yellow.



**5** Touch [Recog Char.] to display the character shape recognized by the device in the 7 × 7 dot character display. The registered character candidate recognized by the device is displayed under [Saved].

You can touch [Alph/Num] to select whether to register the recognized character as a numeric value or alphabet character.

If the character displayed under [Saved] matches the character that you want to register, touch [Save].

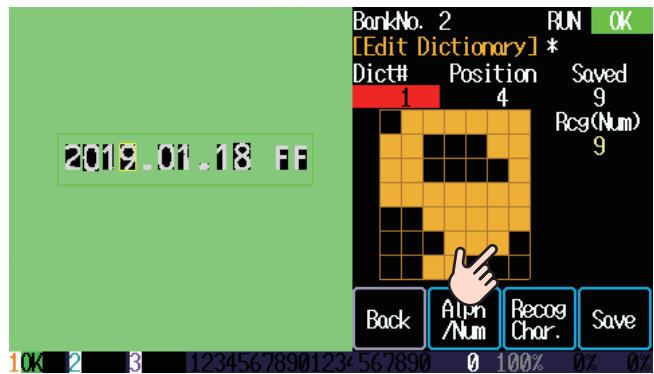
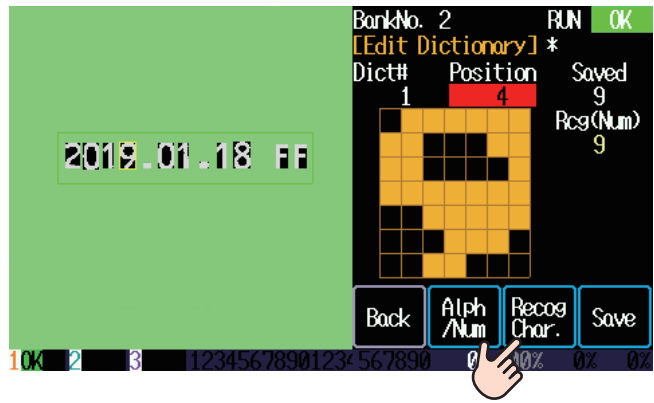

If the character displayed under [Saved] does not match the character that you want to register, use the  and  keys to move the cursor to [Saved], use the  and  keys to select the character that you want to recognize, and then touch [Save].

You can also touch segments in the 7 × 7 dot character display to edit the recognized character shape.



## MEMO

Press the  key and then touch [OK] to delete the displayed dictionary entry.

To continue creating dictionary entries, move the cursor to [Dict#], use the  and  keys to change the dictionary entry number, and then create the dictionary entry by following the same procedure explained above.



## 6 Touch [Back].

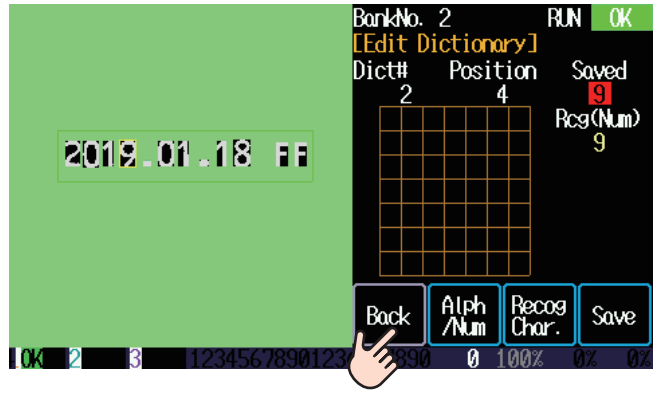

The dictionary entries are created.

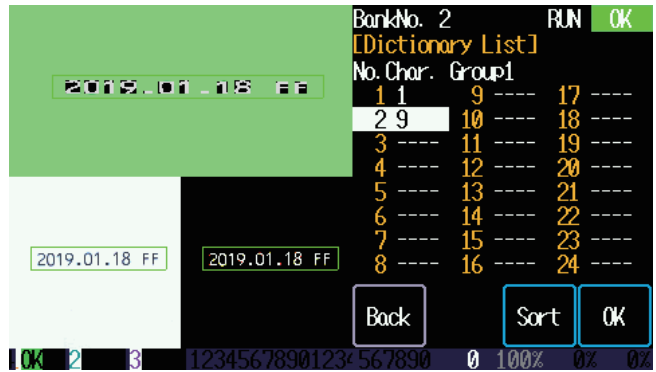

## 7 Touch [Back].



# 6-6 I/O Settings

Configure the settings for the device's I/O and perform I/O tests.

- 1 On the [Settings] screen, touch [Input/Output].

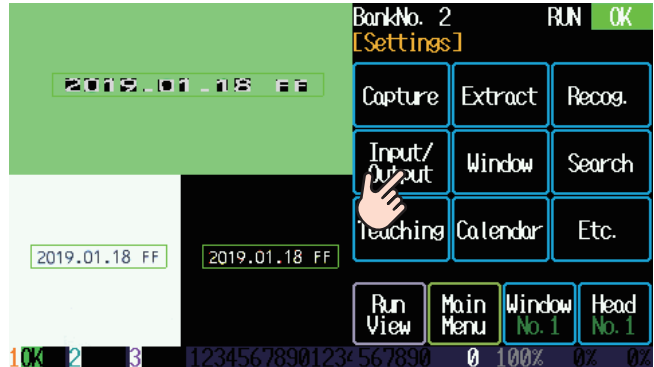

## 6-6-1 Input Settings

Configure the input settings.

- 1 On the [4 Input/Output] screen, touch [Input].

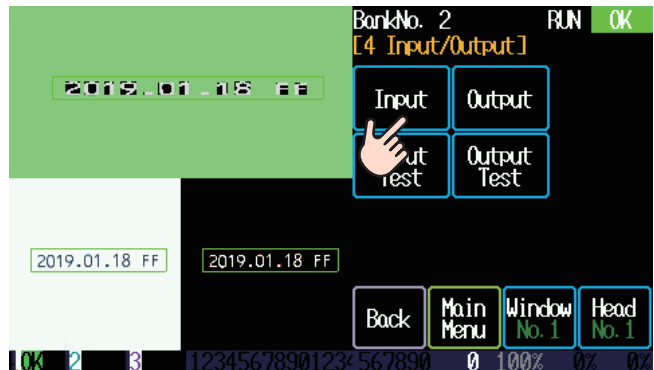

- 2 Select an item.

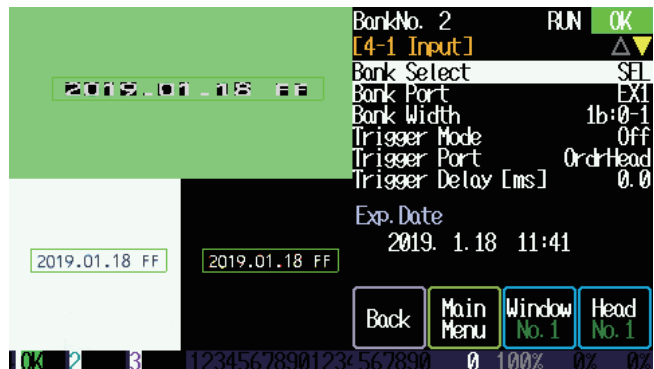

The settings and details are shown below.

Setting	Details	Value (Values in bold are default values.)	Applies to
Bank Select	Set the method used to select the bank. "SEL": Select the bank using the [Bank Select] setting on the controller screen. "PORT": Select the bank using the expansion I/O connector input. "COMM": Select the bank using serial communication commands.	<b>SEL</b> , PORT, COMM	All banks
Bank Port	When [Bank Select] is set to "PORT," select which expansion I/O connector terminal to use.	<b>EX1</b> , EX2, EX3, EX4, EX5, EX6, EX7, EX8, EX9, EX10, T11, T12, T13	All banks
Bank Width	When [Bank Select] is set to "PORT," specify how many inputs to use. With 5 inputs, you can switch between a maximum of 32 banks.	<b>1b:1-2</b> , 2b:1-4, 3b:1-8, 4b:1-16, 5b:1-32	All banks
Trigger Mode	Set the operation timing of the trigger mode. "Off": Images are automatically captured regardless of the state of the trigger mode terminal. "Rose": Images are captured when the trigger mode terminal switches from OFF to ON. "High": Images are continuously captured, inspected and judged while the trigger mode terminal is ON. "Fell": Images are captured when the trigger mode terminal switches from ON to OFF. "Low": Images are continuously captured, inspected and judged while the trigger mode terminal is OFF. When set to "Off," images are continuously captured, measured, judged, and measurement is output.	<b>Off</b> , Rose, High, Fell, Low	All banks
Trigger Port	Select the trigger mode terminal from which the signal will be used as the trigger mode.	T11, T12, T13, <b>OrdHead</b>	All banks
Trigger Delay	Set the delay time from the reception of the trigger mode to the start of the actual image capture. Set this value in units of 0.1 ms (100 μs).	<b>0.0</b> to 6000.0 (unit: ms)	Bank
Sync Pulse Count	Set the number of trigger pulses to receive after the trigger mode is received before capturing the image.	1 to 65535	Bank
Sync Pulse Port	Set the input terminal to use in receiving trigger pulse input. If you set [Sync Pulse Port] to a value other than "Off," the trigger delay setting is disabled, and image capturing will start when the number of pulses specified with [Sync Pulse Count] are received.	<b>Off</b> , EX1, EX2, EX3, EX4, EX5, EX6, EX7, EX8, EX9, EX10, T11, T12, T13	All banks
Force Trigger	When you set [Trigger Mode] to a value other than "Off," set the terminal to use for the forced trigger mode. While the signal is ON, the following procedure will be forcibly performed: images are captured, measured, judged, and measurement is output.	<b>Off</b> , EX1, EX2, EX3, EX4, EX5, EX6, EX7, EX8, EX9, EX10, T11, T12, T13	All banks
Output Reset	Set the input terminal to use when performing the output reset. On the rising edge of the input, OK or NG output will be set to OFF. You cannot set the output to OFF during one-shot output.	<b>Off</b> , EX1, EX2, EX3, EX4, EX5, EX6, EX7, EX8, EX9, EX10, T11, T12, T13	All banks

Setting	Details	Value (Values in bold are default values.)	Applies to
String Add	<p>Set the input terminal to use when performing character string addition.</p> <p>On the rising edge of the input, the numeric values and uppercase letters in the character string of inspection window 1 will be incremented or decremented.</p> <p>If [Str Add Mode] is set to "Up Down" or "WithSave," the next input terminal after the input terminal set here (for example, if you set this setting value to "EX1," the next input terminal is "EX2") will be used as the subtraction input.</p>	<b>Off</b> , EX1, EX2, EX3, EX4, EX5, EX6, EX7, EX8, EX9, EX10, T11, T12, T13	All banks
Str Add Mode	<p>When you set [String Add] to a value other than "Off," set the character string addition mode.</p> <p>"Count Up": Characters will only be incremented. On the rising edge of the input specified with [String Add], the numeric values and uppercase letters in the character string of inspection window 1 will be incremented.</p> <p>"Up Down": The characters will be incremented or decremented. On the rising edge of the input specified with [String Add], the numeric values and uppercase letters in the character string of inspection window 1 will be incremented. On the rising edge of the next input terminal, the characters will be decremented.</p> <p>"WithSave": Each time the characters are incremented or decremented, the character string will be saved to the device's memory.</p>	<b>Count Up</b> ; Up Down; WithSave	All banks
Str Add Reset	<p>When you set [Str Add Mode] to a value other than "WithSave," specify the character string addition reset input terminal.</p> <p>The resulting value of the addition or subtraction from character string addition will be initialized.</p>	<b>Off</b> , EX1, EX2, EX3, EX4, EX5, EX6, EX7, EX8, EX9, EX10, T11, T12, T13	All banks
Teach Input	<p>When the device is receiving teaching input from an external source, set the terminal to receive this input.</p> <p>While the input is set to ON, perform the positioning of the image that you want to register and then perform teaching on the falling edge of the input.</p>	<b>Off</b> , EX1, EX2, EX3, EX4, EX5, EX6, EX7, EX8, EX9, EX10, T11, T12, T13	All banks
Batch Trigger Reset	<p>Set the input terminal to use when resetting the number of times that batch triggers have occurred.</p> <p>The current number of times that triggers have occurred will be reset on the rising edge of the input.</p> <p>The next time an image is captured, the trigger count will be 1.</p>	<b>Off</b> , EX1, EX2, EX3, EX4, EX5, EX6, EX7, EX8, EX9, EX10, T11, T12, T13	All banks

## Reference .....

### What is trigger pulse input?

If the conveyance speed is not fixed among devices and equipment, it is not possible to use time control by way of trigger delay to capture images with the appropriate timing. In this situation, control the timing by counting the number of pulse signals generated by a rotary encoder.

The minimum width (the time that a pulse is ON) of pulses received from the encoder is 120  $\mu$ s, and the minimum pulse period is 250  $\mu$ s (4 kHz).

\* When you use this function, the trigger delay time setting is disabled.

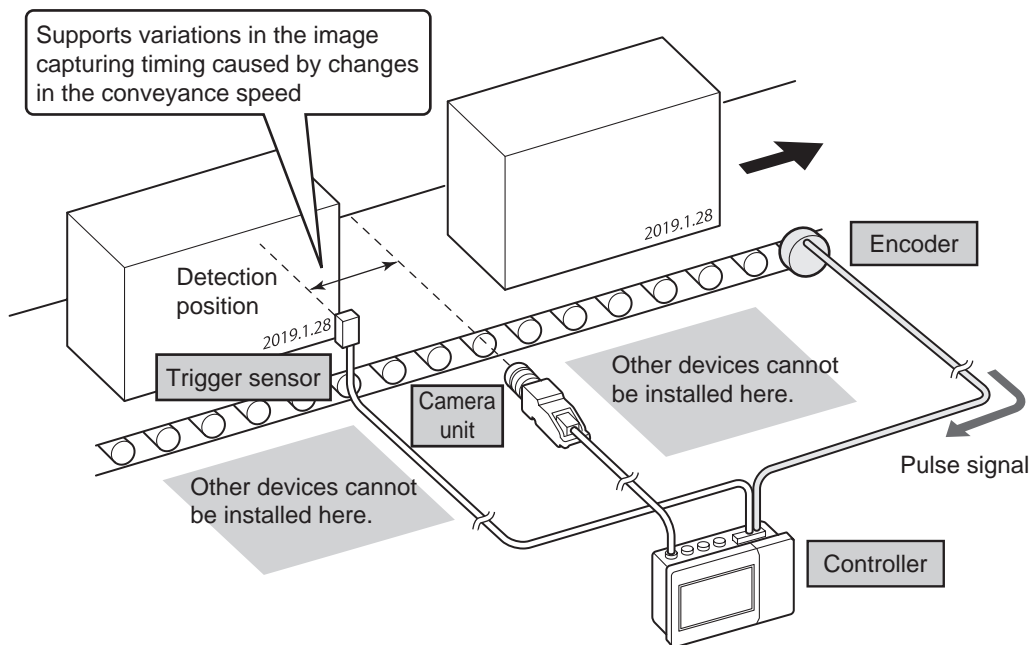

---

### MEMO

When you use trigger pulse input, select an encoder that uses open collector output.

- When using the MVS-DN/MVS-DN-E: NPN type
- When using the MVS-DP/MVS-DP-E: PNP type

---

## 6-6-2 Output Settings

Configure the settings related to output.

- 1 On the [4 Input/Output] screen, touch [Output].

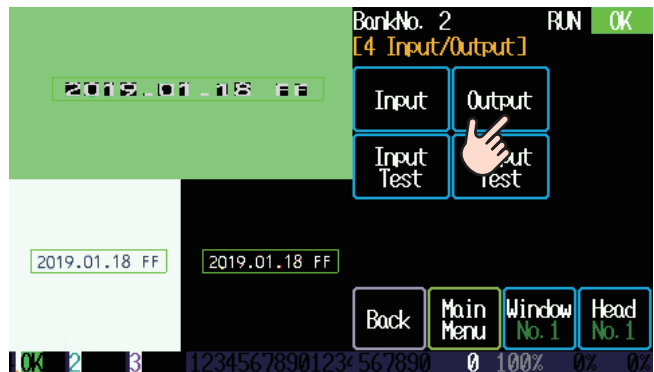

- 2 Select an item.



The settings and details are shown below.

Setting	Details	Value (Values in bold are default values.)	Applies to
Output Logic	Set to invert the result of the overall judgment. "Normal": When the judgement results for all inspection windows are OK, OK is output. If an NG judgment occurs, NG is output. "Invert": When the judgement results for all inspection windows are OK, NG is output. If an NG judgment occurs, OK is output.	<b>Normal</b> , Invert	<input type="text" value="Bank"/>
Window OR	Set to output OK if the judgement result of at least one of the inspection windows is OK.	<b>Off</b> , On	<input type="text" value="Bank"/>
OKNG One-Shot	Set to switch OK/NG output to one-shot output. Each time a judgment result is ready, output will be generated for the length of time set with [OKNG Off-Delay]. When you set this value to "Shift," the on-delay time output is sampled at intervals of 1 ms, is shifted, and is delayed.	<b>Off</b> , On, Shift	<input type="text" value="All banks"/>
OKNG Off-Delay [ms]	Set the off-delay time of the OK/NG output in units of 1 ms. During one-shot output, this value is the output time. When you set [OKNG One-Shot] to "On" and this setting value to "0," the output will be maintained.	<b>0</b> to 5000 (ms)	<input type="text" value="All banks"/>
OKNG On-Delay [ms]	Set the on-delay time of the OK/NG output in units of 1 ms. During one-shot output, this value is the output time. When you set [OKNG One-Shot] to "Shift," the OK/NG output is delayed by the time set here.	<b>0</b> to 5000 (ms)	<input type="text" value="All banks"/>
Output Shift	Set to delay the timing when OK/NG output is set to ON by the number of image captures set here. Use this setting value when the output process is after the detection location.	<b>0</b> to 63	<input type="text" value="All banks"/>
NG Filter	Set NG output to ON when the number of consecutive NG judgments exceeds the value set here. Use this setting when consecutive NG judgments occur such as when a stamp is out of ink or when the printer's date setting is incorrect.	<b>0</b> to 255	<input type="text" value="Bank"/>
NG Filter OK Count	Set to enable the NG output filter when the number of OK formats is greater than or equal to the value set here. You can set this value when the [NG Filter] value is set. If the number of OK formats is less than the set value, an NG judgment will be immediately generated.	<b>0</b> to 15	<input type="text" value="Bank"/>
Ready Port	Set the terminal from which to start the ready output and the odd parity output of the bank number. The ready output is set to ON when images can be captured. This output is set to OFF during bank switching and teaching.	<b>EY1</b> to EY20	<input type="text" value="All banks"/>
Ready Width	Set whether to use ready output. "Off": Ready output will not be used. "On": Ready output is generated when the device is ready. "Parity": Ready output and odd parity output of the bank number will be generated.	<b>Off</b> , On, Parity	<input type="text" value="All banks"/>

Setting	Details	Value (Values in bold are default values.)	Applies to
Busy Port	Set the terminal from which to start the busy output. The busy output is set to ON when image capturing starts and is set to OFF when the judgment result is available.	<b>EY1</b> to EY20	All banks
Busy Enable	Set whether to use the busy output. Set this to "On" to require a confirmation signal in order to prevent the reception of the subsequent trigger signal during image capture.	<b>Off</b> , On	All banks
Window Port	Set the terminal to start when outputting judgment results separately for the inspection windows. The inspection windows will be assigned to the outputs of the expansion I/O connector in order starting with inspection window 1.	<b>EY1</b> to EY20	All banks
Window Width	Set the number of outputs to use when generating judgment results separately for the inspection windows. For example, if you set this to "3bit," the judgment results for inspection window 1 to inspection window 3 will be generated from the expansion I/O connector.	<b>Off</b> , 1bit, 2bit, 3bit, 4bit	All banks
Window One-Shot	Switch the inspection window output to one-shot output. The output waveform is the same as for the [OKNG One-Shot] setting.	<b>Off</b> , On	All banks
Window Polarity	Use this setting to invert the inspection window output results. "Normal": When judgement results for all the formats within the inspection window are OK, the inspection window output is set to ON. "Invert": When judgement results for all the formats within the inspection window are OK, the inspection window output is set to OFF.	<b>Normal</b> , Invert	All banks
Trigger Check	When the trigger mode ON or OFF time exceeds the consecutive ON time for the input, trigger check output becomes ON. Use this setting value in cases where you are performing detections but you cannot isolate trigger modes because of workpieces being close to each other. Whether the trigger check output becomes ON or OFF varies depending on the trigger mode settings.	<b>Off</b> , On	All banks
TrgChk Time [ms]	Set the time limit for the trigger mode to be ON or OFF. Set this value in units of 1 ms.	<b>0</b> to 6000 (unit: ms)	Bank
TrgChk Port	Set the output terminal for the trigger check.	<b>EY1</b> to EY20	All banks
TrgChk One-Shot	Switch the trigger check output to one-shot output. Each time a judgment result is ready, output will be generated for the off-delay time.	<b>Off</b> , On	All banks
TrgChk Off-Dly [ms]	Delay the trigger check output by this off-delay time. Set this value in units of 1 ms.	<b>0</b> to 5000 (unit: ms)	All banks

Setting	Details	Value (Values in bold are default values.)	Applies to
TrgChk On-Dly [ms]	Delay the trigger check output by this on-delay time. Set this value in units of 1 ms.	<b>0</b> to 5000 (unit: ms)	All banks
TriggerFilter	The input filter time used when detecting the trigger. The unit is milliseconds (ms). Use this when Trigger Check is set to "On."	0 to <b>30</b> to 50	All banks
Batch Trigger	Set to specify the number of judgments that will be grouped into a batch for OK/NG output. If the set number of OK judgments occur, one OK is output. If one or more NG judgments occur, one NG is output.	<b>0</b> to 12	Bank
BatchTrg Port	Set the terminal from which to start the output of the judgment results. For example, if [Batch Trigger] is set to "3" and you set this value to "EY1," the first judgment result will be generated from EY1, the second judgment result will be generated from EY2, and the third judgment result will be generated from EY3.	<b>EY1</b> to EY20	All banks
BatchTrg One-Shot	Switch the batch trigger output terminal to one-shot output. The output waveform is the same as for the [OKNG One-Shot] setting.	<b>Off</b> , On	All banks
BatchTrg Polarity	Set to invert the output of the batch trigger output terminal. "Normal": When the judgment result of the terminal is OK, the output is set to ON. "Invert": When the judgment result of the terminal is NG, the output is set to ON.	<b>Normal</b> , Invert	All banks
Output Limit [10 ms]	Set to limit the inspection time to a set length of time. Set this value in units of 10 ms. You cannot specify a time that is shorter than the inspection time for OK judgments.	<b>0</b> to 200 (unit: ms)	Bank

## 6-6-3 Test the Input

Test the continuity of expansion I/O terminals EX1 to EX10 and T11 to T13.

During the test, the device stops operating.

- 1 On the [4 Input/Output] screen, touch [Input Test].

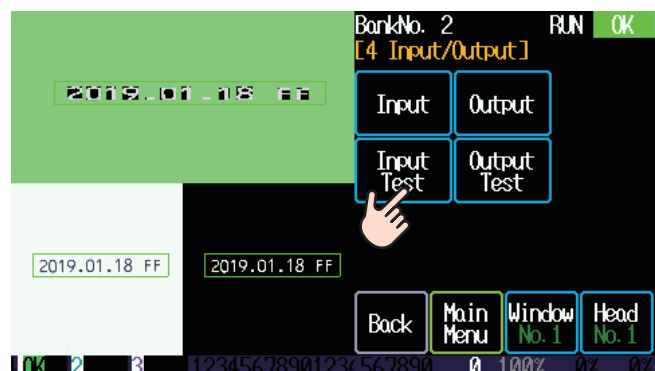

## 2 Touch [OK].

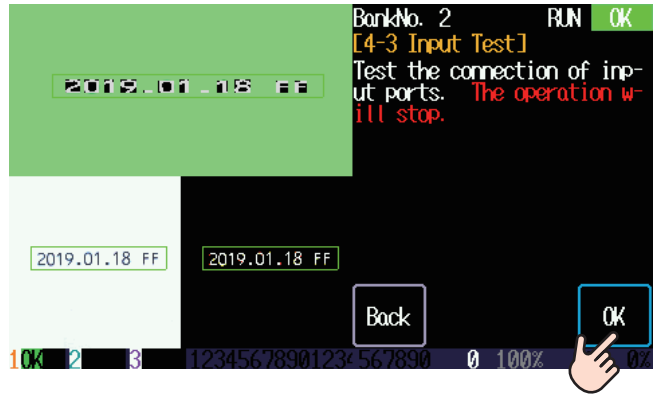

The device stops operating and the names of those terminals whose inputs are currently ON light.

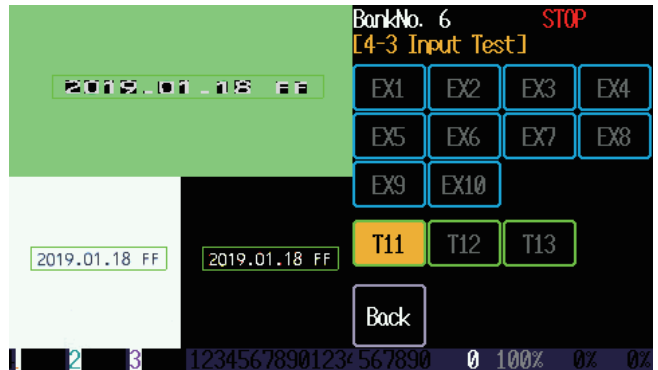

## 3 Touch [Back].

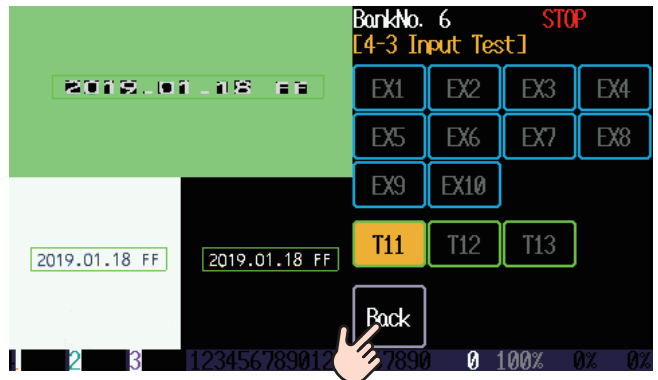

## 6-6-4 Test the Output

Test the continuity of expansion I/O terminals EY1 to EY20, OK1 to OK3, and NG1 to NG3.

During the test, the device stops operating.

- 1 On the [4 Input/Output] screen, touch [Output Test].

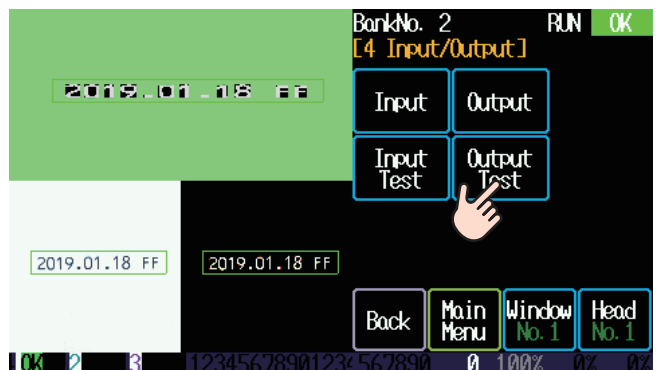

- On the [4-4 Output Test] screen, touch [OK].

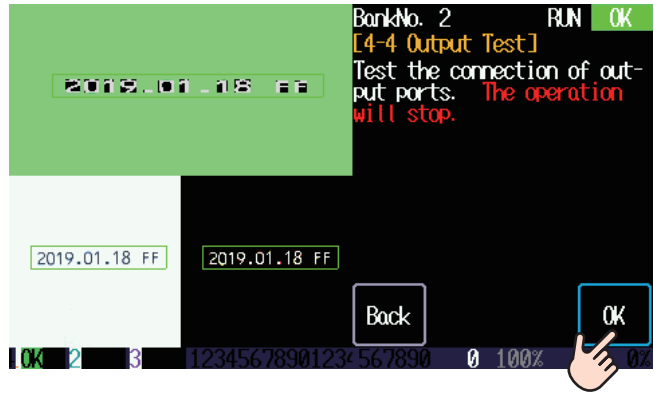

The device stops operating and the [4-4 Output Test] screen is displayed. Touch the key that corresponds to the terminal whose output you want to test. The terminal's output is set to ON.

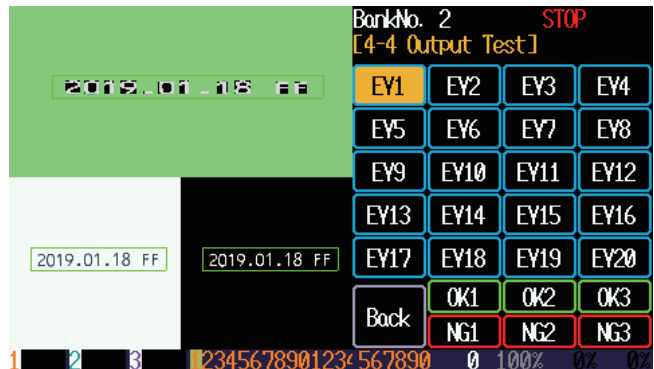

- Check the operation of the connected device.
- Touch [Back].

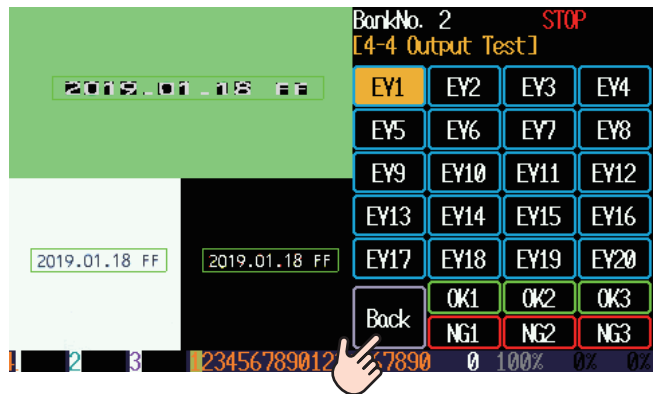

### MEMO

During the output test, the lighting output is set to ON for all channels.

# 6-7 The Inspection Window

Before you perform an inspection, set the area of the displayed image that will be used as the inspection target. Use this procedure when you want to specify multiple inspection windows and when you want to adjust the position and size of an inspection window after setup.



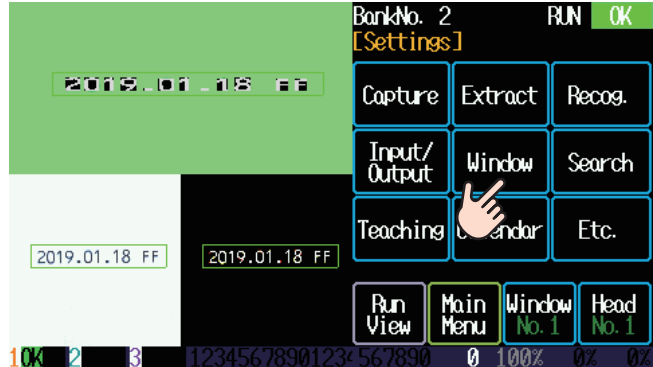

**1** On the [Settings] screen, touch [Window].

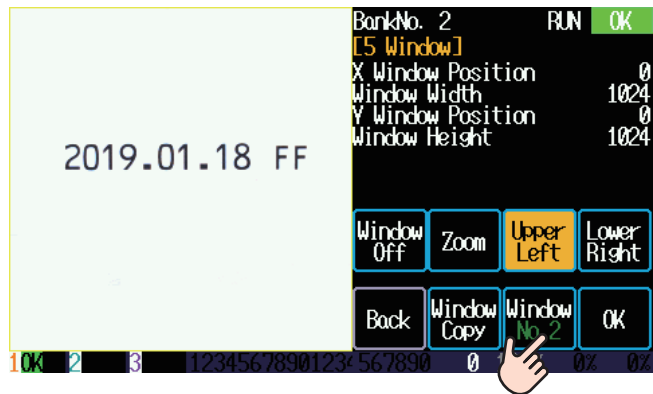

**2** On the [5 Window] screen, touch [Window No. X] to select the inspection window to set.



**3** Touch [Upper Left], and then touch the point on the image that you want to set as the upper-left corner of the inspection window.

After you specify this point, press the  and  keys to make fine adjustments to the position in the vertical direction and the  and  keys to make fine adjustments to the position in the horizontal direction.



## MEMO

Touch [Zoom] to zoom in on the image centered around the point that you have touched. The image displays at a magnification of 2x and 4x.

- 4** Touch [Lower Right]. Then, using the same procedure that you used to set the upper-left corner, set the point on the image to use as the lower-right corner of the inspection window.

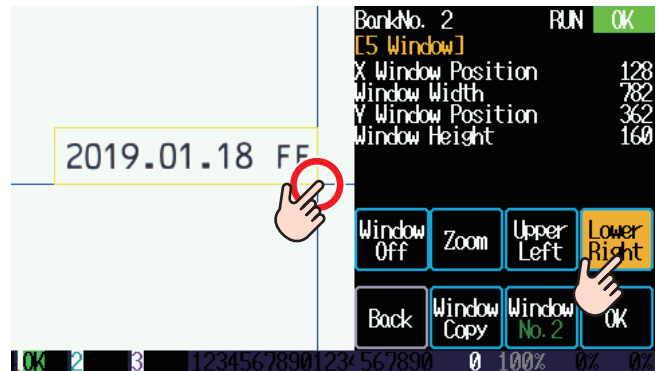

- 5** To enable the inspection window, touch [Window On] to change the key to [Window On].

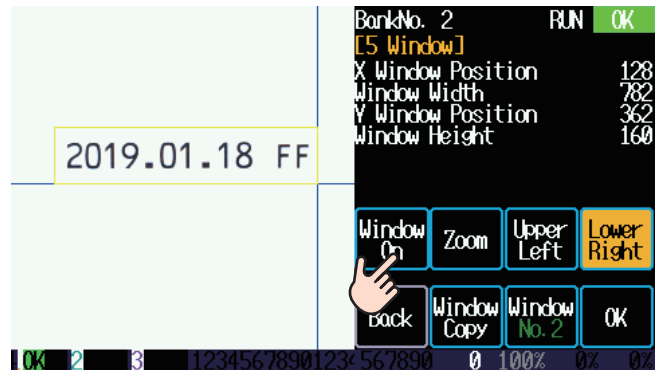

### MEMO

If the key is set to [Window Off], no inspection will be performed even if you set the inspection window.

- 6** Touch [OK].

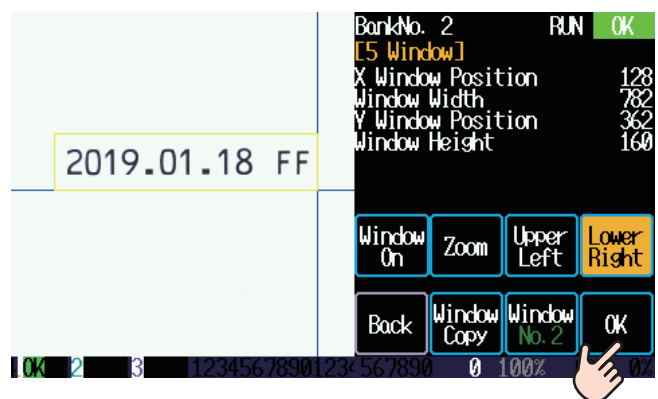

## ■ Copy an inspection window

You can copy the settings of the current inspection window to a different inspection window.

Use this function to inspect multiple instances of the same workpiece at the same time.

- 1 On the [5 Window] screen, touch [Window Copy].

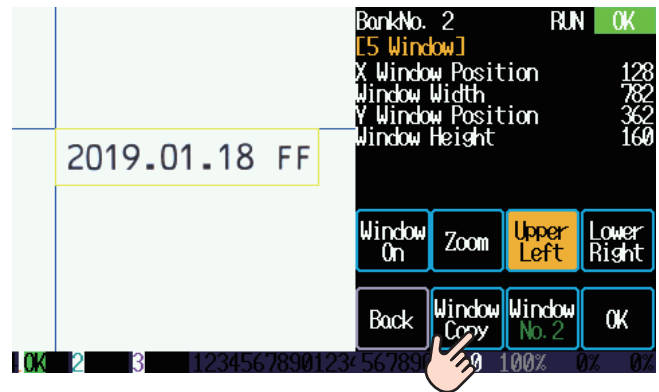

- 2 Touch [Window No. X] on the left to select the number of the source inspection window. Then, touch [Window No. X] on the right to select the number of the destination inspection window.



- 3 Touch [OK].

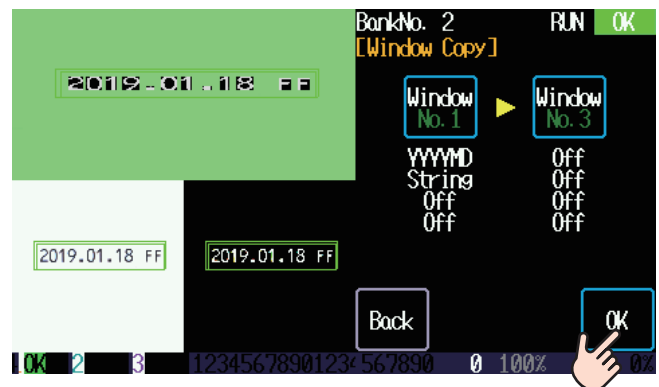

# 6-8 Search Within Images

When printed characters are offset from the reference position, you can use the search function to shift the inspection window to match the offset of the printed characters.

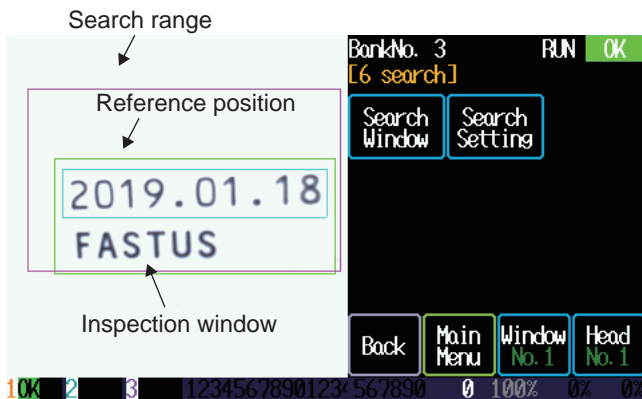

Set the reference position and the search range.

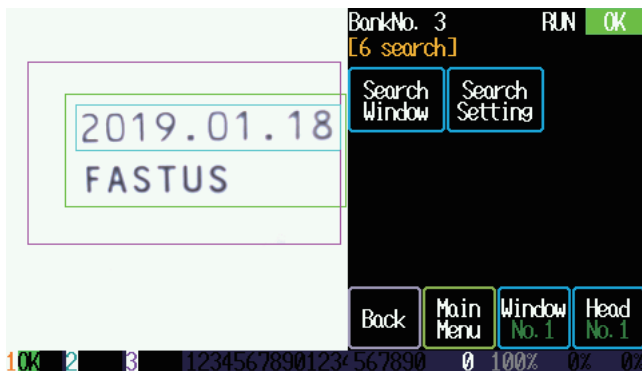
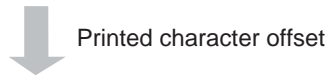

The inspection window is shifted to match the offset of the printed characters.

## MEMO

When you use the search function, the inspection time may greatly increase depending on the settings.

- 1 On the [Settings] screen, touch [Search].

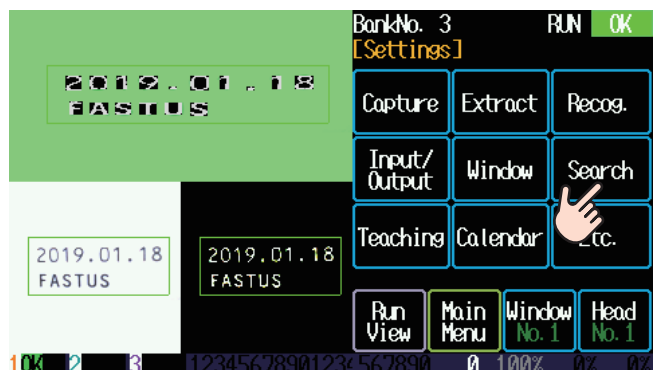

## 6-8-1 The Search Window

Set the reference position and the search range.

- 1 On the [6 Search] screen, touch [Search Window].

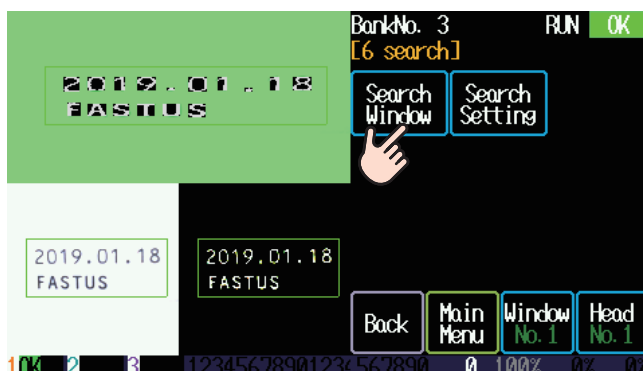

- 2 Touch [Raw Image] or [Proc Image] to select the image to use as the search target.

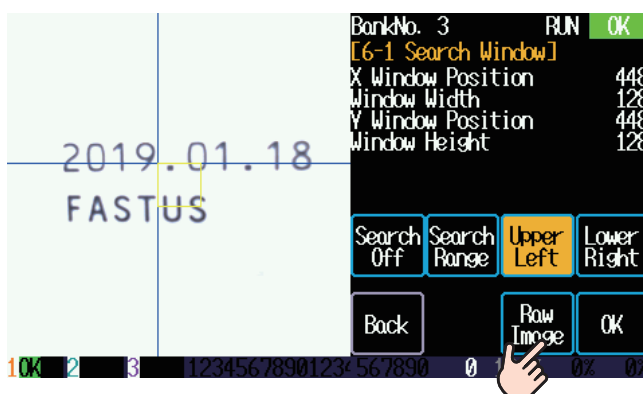

- 3 Touch [Upper Left], and then touch the upper-left point of the region that you will set as the reference position.

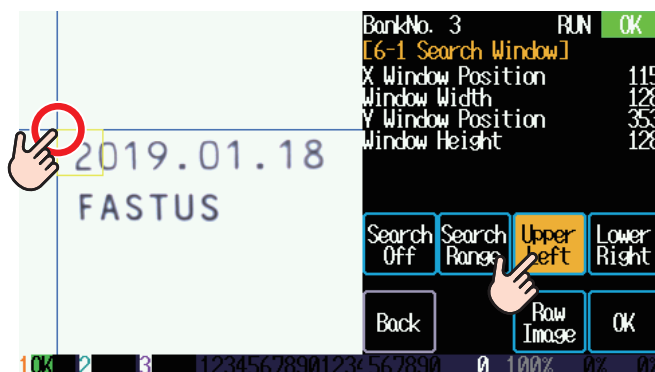

- 4 Touch [Lower Right], and then touch the lower-right point of the region that you will set as the reference position.

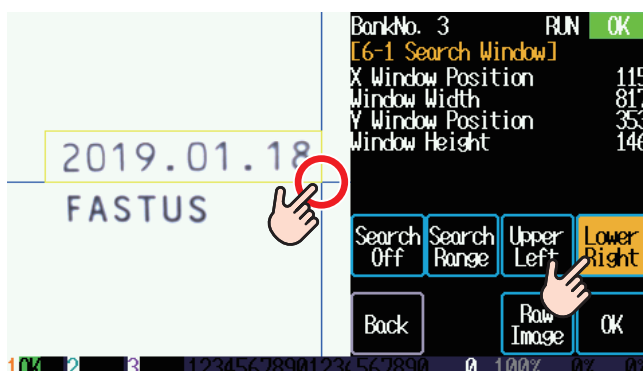

**5** Touch [Search Range].

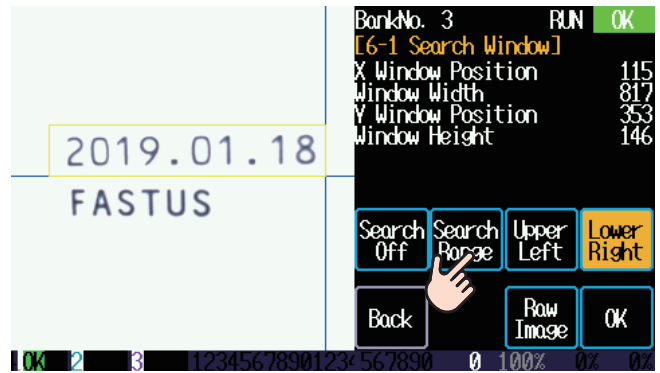

**6** Touch the screen to set the search range.

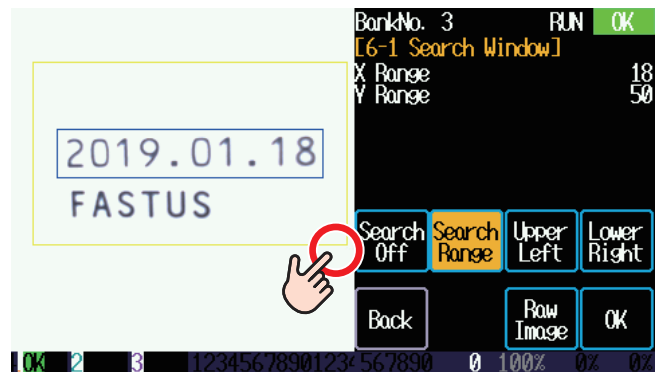

**7** Touch [Search Off] to change the key to [Search On].

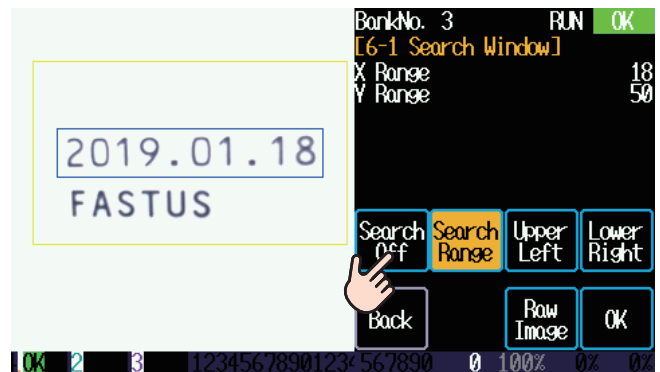

## 8 Touch [OK].

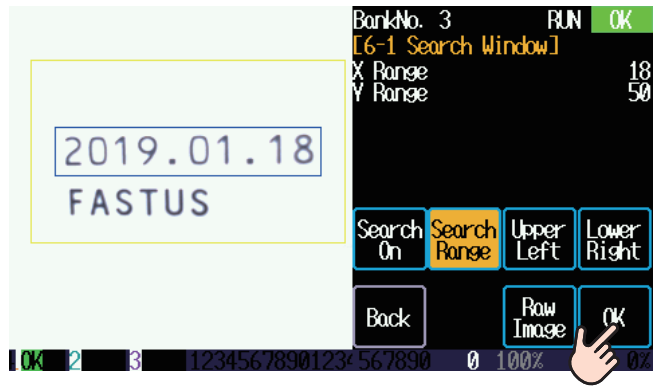

This completes the procedure for setting the search window.

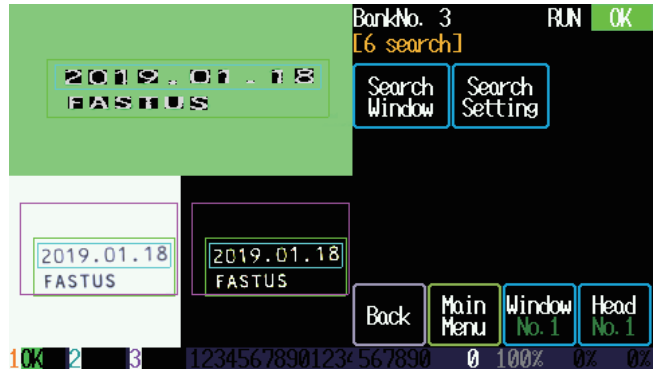

## 6-8-2 Search Settings

Configure the search settings.

### Caution

If [Region Of Interest] is set to "No Bg.," do not configure the search function settings. Confirm this setting by touching [Settings], [Capture], and then touching [Camera].

- 1 On the [6 Search] screen, touch [Search Settings].

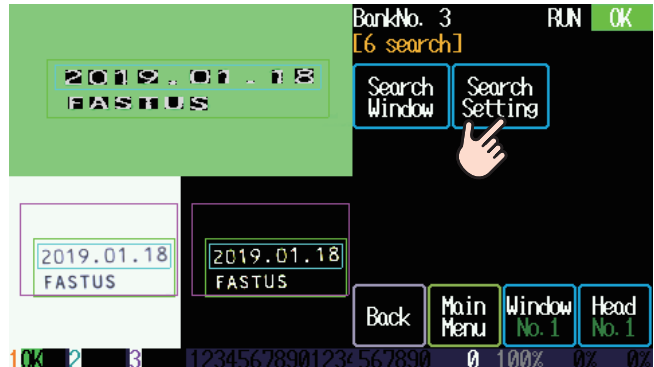

- 2 Select an item.

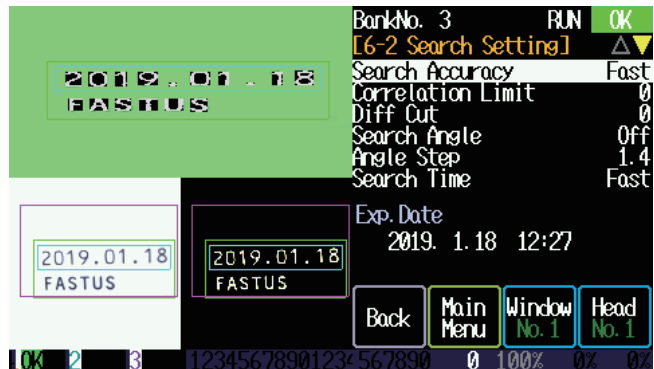

The settings and details are shown below.

Setting	Details	Value (Values in bold are default values.)	Applies to
Search Accuracy	Set the accuracy to use when performing searches. "Accuracy" will increase the search accuracy but the processing time will also increase. "Fast" will decrease the processing time but will also decrease the search accuracy.	Accuracy, Normal, <b>Fast</b>	<input type="text" value="Bank"/>
Correlation Limit	If the search correlation value is less than or equal to the value set here, the result will be an NG judgment and no inspection is performed.	<b>0</b> to 100	<input type="text" value="Bank"/>
Diff Cut	When each pixel of the image in the search range is compared, if the difference is less than or equal to the value set here, the difference will be rounded down. Specify a large setting value to improve the resiliency against changes in the image capturing conditions. Specify a small setting value to enable accurate distinctions even when the color differences are small.	<b>0</b> to 15	<input type="text" value="Bank"/>
Search Angle	Set the angle range to use when searching in the direction of rotation.	<b>Off</b> , ±1.4, ±2.8, ±5.6, ±11, ±22, ±45, ±90, ±180 (°)	<input type="text" value="Bank"/>
Angle Step	Set the minimum unit to use when searching in the direction of rotation. The smaller the value, the higher the accuracy. However, this also increases the processing time.	<b>1.4</b> , 2.8, 5.6, 11, 22, 45, 90, 180	<input type="text" value="Bank"/>
Search Time	Specify the processing time of the search. "Fast:" The smaller the offset from the reference position, the shorter the processing time. "Constant:" Regardless of the offset from the reference position, the entirety of the set range will be searched. By using this setting, you can increase the certainty of the search, but you cannot shorten the processing time.	<b>Fast</b> , Constant	<input type="text" value="Bank"/>

# 6-9 Teaching Settings

Configure the settings related to teaching.

- 1 On the [Settings] screen, touch [Teaching].

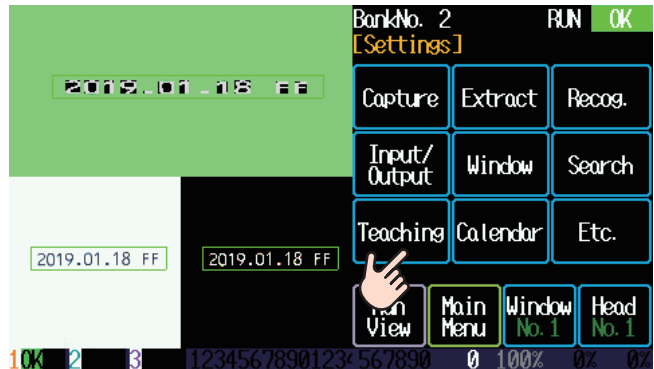

- 2 Select an item.

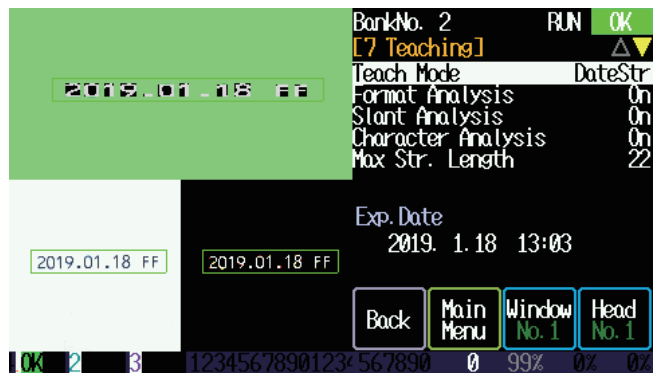

The settings and details are shown below.





Setting item	Setting details	Setting value (Values in bold are default values.)	Applies to
Teach Mode	Set the recognition method to use during teaching. "DateStr:" The inspection will be performed on the basis of the date and the character string. "Date:" The inspection will be performed on the basis of the date. "String:" The inspection will be performed on the basis of the character string. "No. OfStr:" The inspection will be performed on the basis of the number of characters.	<b>DateStr</b> ; Date; String; No. OfStr	<input type="text" value="Bank"/>
Format Analysis	Set to automatically set the style of data to read for each format during teaching. For dates, the inspection will be automatically performed in the YYYYMD; YYYYM; YYMD; or YYM format. If you specify "Off," teaching will be performed according to the style of data that has been set with the format.	Off, <b>On</b>	<input type="text" value="Bank"/>
Slant Analysis	Set to automatically adjust the slant of characters during teaching. If you only want to perform the automatic setting of dates and characters, specify "Off."	Off, <b>On</b>	<input type="text" value="Bank"/>
Character Analysis	Set to automatically adjust the size of characters during teaching. If you only want to perform the automatic setting of dates and characters, specify "Off."	Off, <b>On</b>	<input type="text" value="Bank"/>
Max Str. Length	If you have selected the character string format during teaching, set the maximum number of characters when registering character strings. The maximum number of characters for a single inspection window is 22 characters including all the formats. The maximum number of characters for a single bank is 64 characters including delimiters.	1 to <b>30</b>	<input type="text" value="Window"/>
Cutout mode	Select the cutout algorithm to use in teaching. Change this setting if teaching cannot be performed well.	<b>rev1</b> , rev2	<input type="text" value="All banks"/>

# 6-10 The Calendar Timer

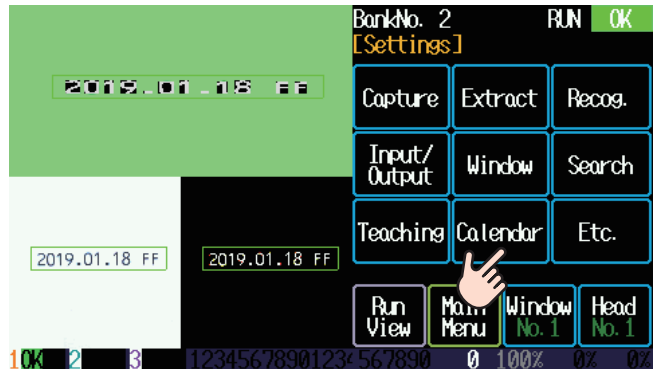
Set the controller's built-in calendar timer.

- 1 On the [Settings] screen, touch [Calendar].



- 2 On the [8 Calendar] screen, use the  and  keys to move the cursor to the value that you want to set, and then use the  and  keys to set the value.

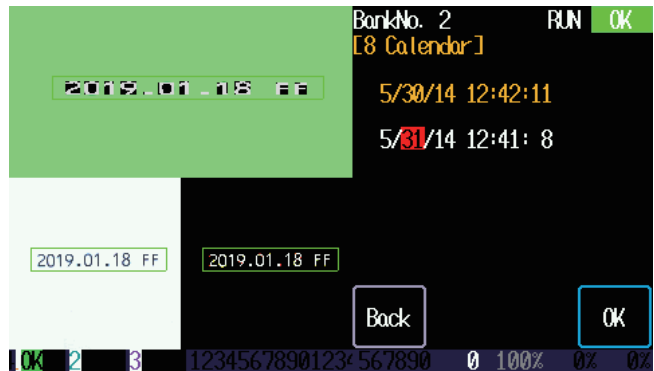

- 3 Touch [OK].

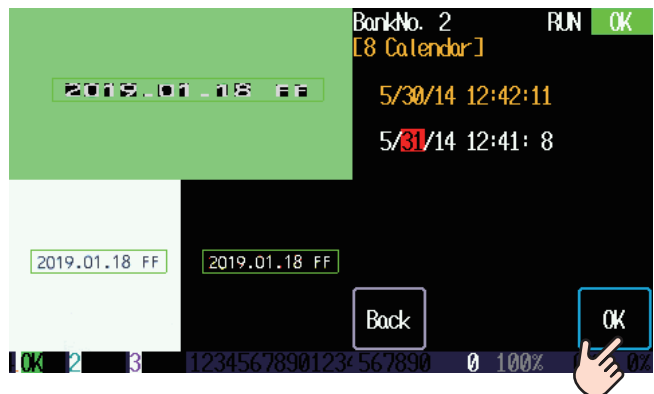

# 6-11 Other Settings

Configure other settings not included in the major setting categories.

**1** On the [Settings] screen, touch [Etc.].

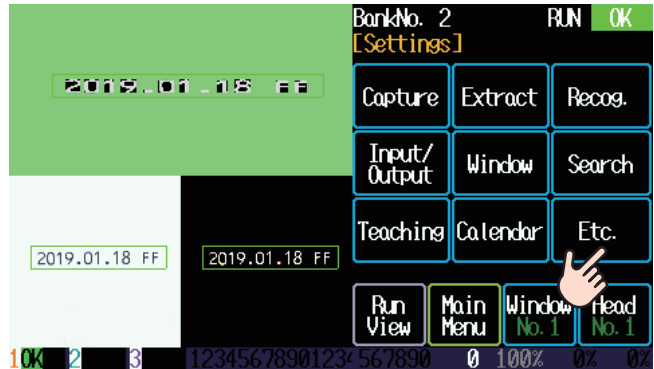

**2** Select an item.



The settings and details are shown below.

Setting	Details	Value (Values in bold are default values.)	Applies to
Display Window	Set the method to use in drawing judgment images. "All:"The judgment image will be displayed on top of the captured image after position correction. "1 Window:" Only the selected window will be displayed. "Only NG:" The All display will be applied only when an NG judgment occurs.	<b>All</b> , 1 Window, Only NG	All banks
Save Image	Set the method to use in saving images. "Off:" Images will not be saved. "Turn NG:" Images will be saved when an OK judgment changes to an NG judgments. "All NGs:" All NG images will be saved. "All:" All images will be saved. While an image is being saved, any other images that are captured cannot be saved.	<b>Off</b> , Turn NG, All NGs, All	All banks
Start-up String	When you set "On," the [3-3 Edit String] screen will be displayed when the device starts.	<b>Off</b> , On	All banks

Setting	Details	Value (Values in bold are default values.)	Applies to
Easy String Edit	Set the [Edit String] screen to simple string editing mode. "On:" Character strings will be edited in the simple string editing mode. "Off:" Character strings will be edited in the normal string editing mode.	<b>Off</b> , On	All banks
BackLightTimer	Set the amount of time that must pass with no screen operations before the backlight is dimmed. If you specify "0," the backlight will never be dimmed.	0 to <b>300</b> to 3600 (seconds)	Controller
2-Screen Lock	Set whether to prevent a user from switching the screen without pressing the  key and touching the screen at the same time when the controller has been switched to the 2-screen display (this is the 2-Screen Lock function).	<b>Off</b> , On	Controller
2-Compressed	Set whether to compress the display of each head in the horizontal direction to allow display of the status monitor when the controller has been switched to the 2-screen display (this is the 2-Compressed function).	<b>Off</b> , On	Controller
Video Output	Select the output method of the video output signal. (Only available when a video output unit is attached.)	<b>Off</b> , PAL, NTSC	Controller
Video Screen*	Select the type of video output screen. (Only available when a video output unit is attached.)	<b>Full</b> , Normal	Controller
Baud Rate	Set the baud rate to use when performing RS-232C communication from the controller.	9600, 19200, 38400, 57600, <b>115.2k</b> , 250k, 312.5k, 500k (bps)	Controller
Verify Char Head	Set the head number to use when writing recognized character strings to the controller. The recognized character string of inspection window 1 will be sent to the controller.	<b>Off</b> , Head1, Head2, Head3	Controller
Verify Char Send	Load an edited character string and send it from the controller's RS-232C terminal to a different controller. In this case, use [Verify Char Head] to specify the reference head. You can share the character string to verify through the use of a camera unit connected between multiple controllers.	<b>Off</b> , On	Controller
Verify Char Store	Set to read a recognized character string from another head connected to the same controller as the comparison target character string of the set inspection window. Set the other head with [Verify Char Head].	<b>Off</b> , Window1, Window2, Window3, Window4	Bank

\* This setting is supported by version 2.6 and later of the controller.



## Other Functions

This chapter explains how to initialize settings, lock settings with passwords, and the barcode verification function.

# 7-1 Check the Hardware Version

Check the version of the device.

- 1 On the [Main Menu] screen, touch [System].

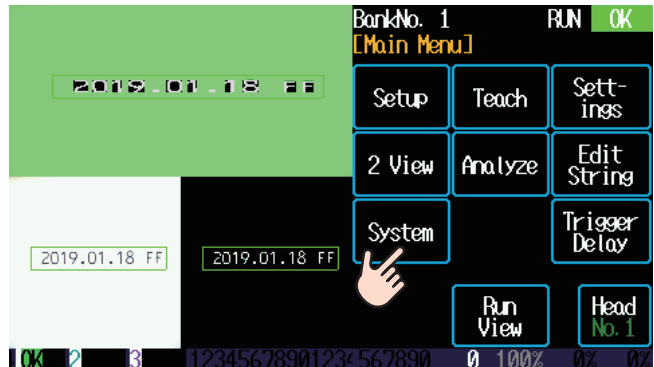

- 2 On the [System] screen, touch [Version].

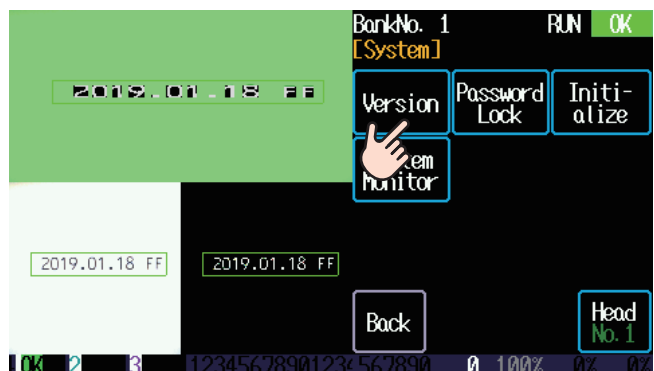

The version of the FPGA and software of the device are displayed.



# 7-2 Initialize Settings

Return the settings of the currently selected bank to their default values.

You can also initialize the settings of all banks and of the system (a complete initialization).

## ■ Initializing the settings of the current bank

1 On the [Main Menu] screen, touch [System].

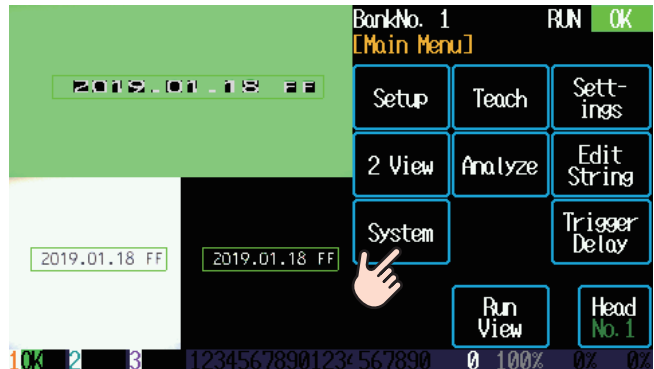

2 On the [System] screen, touch [Initialize].

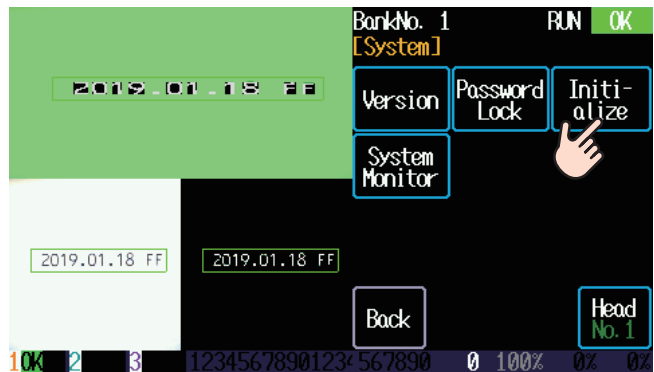

3 Touch [OK].



### MEMO

The setting items listed in "6-11 Other Settings" (page 6-69) that show  in the "Applies to" column will not be initialized.

## ■ Initializing the settings of all banks and of the system

- 1 On the [Main Menu] screen, touch [System].

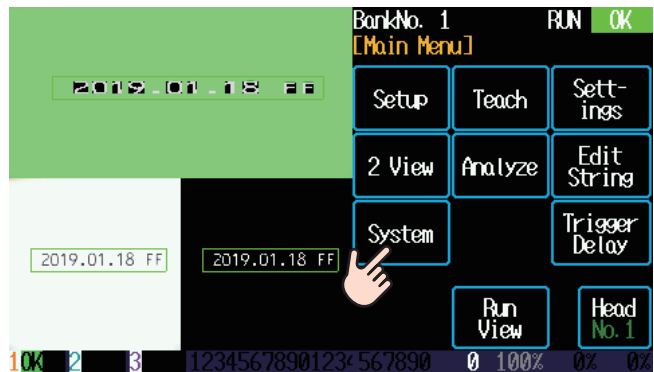

- 2 On the [System] screen, touch and hold [Initialize].

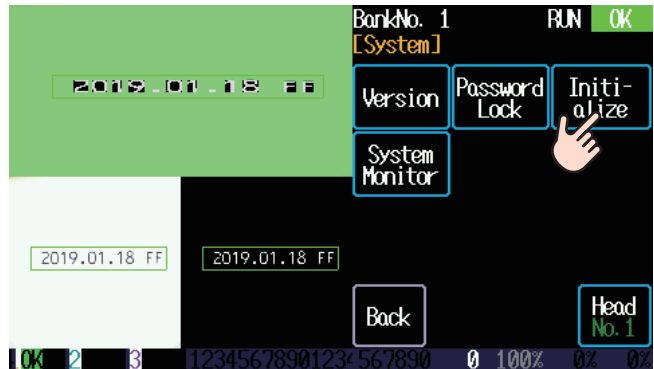

- 3 Touch [OK].

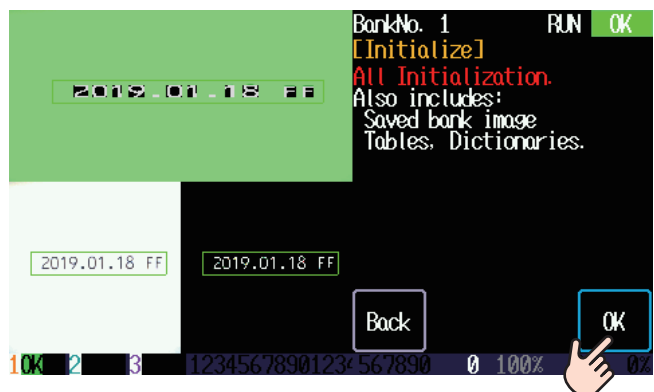

### MEMO

The setting items listed in "6-11 Other Settings" (page 6-69) that show  in the "Applies to" column will not be initialized.

# 7-3 Lock Settings with Passwords

Configure the settings to create operational limits such as restricting a person's ability to change the device settings.

## 7-3-1 Set or Change the Password

Set a new password or change the currently set password.

Use up to four numeric characters to set the password.

- 1 On the [Main Menu] screen, touch [System].

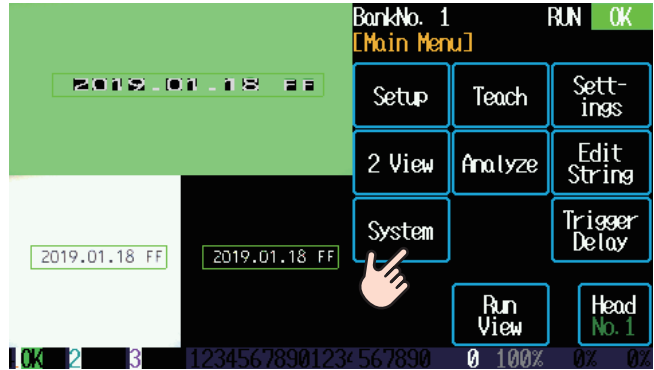

- 2 On the [System] screen, touch [Password Lock].

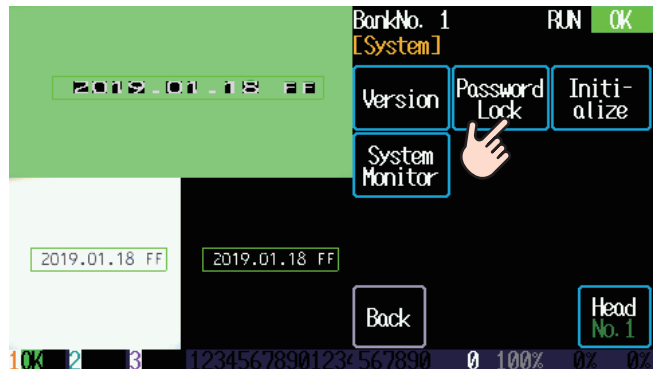

- 3 Touch [Change Password].

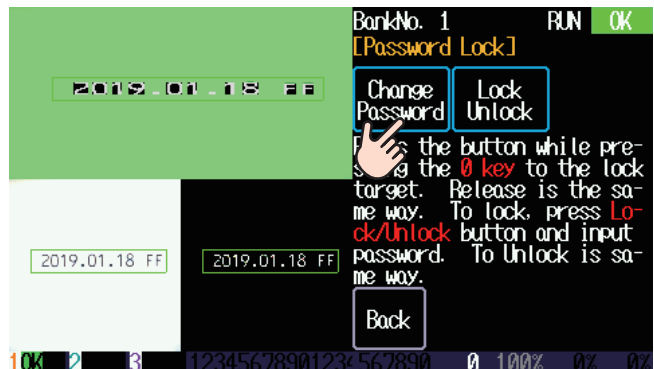

- 4** If you are setting a new password, do not enter anything. If you are changing the currently set password, input the current password using the numeric keys.

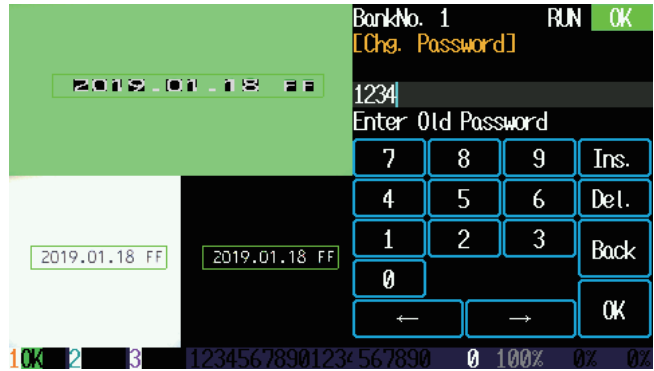

### MEMO

The factory default value is no password. Also, if you initialize the settings of all banks and of the system (a complete initialization), the password is also initialized so that no password is set.

- 5** Touch [OK].

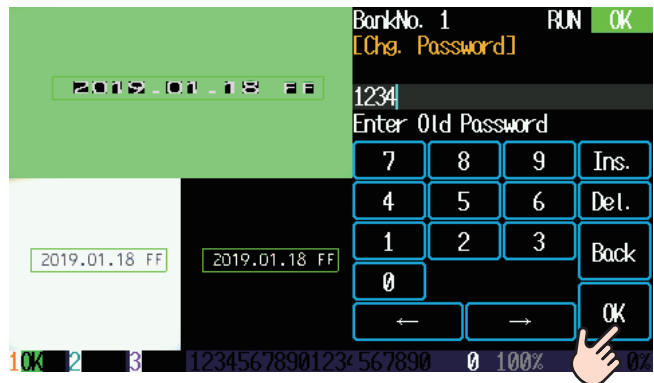

- 6** Enter the new password using the numeric keys.

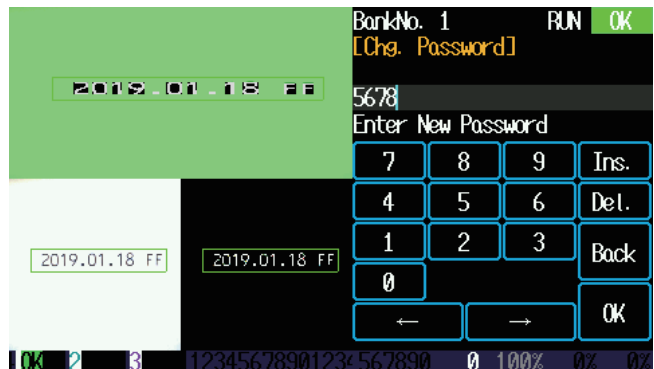

- 7** Touch [OK].

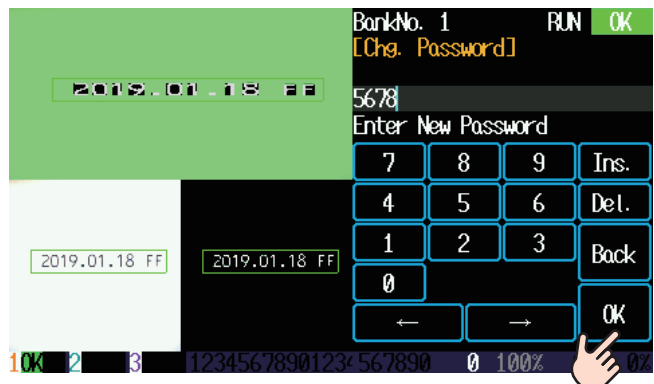

### MEMO

When you change the current password, if you enter the current password incorrectly, the message "Mismatch password." will display and you will not be able to change the password. To change the password, touch [Back] and then enter the password again.

## 7-3-2 Set Items to Lock with the Password

When you want to apply the password lock to a specific setting, perform the step below in advance to set the item as a target for the password lock.

- 1 While pressing , touch the item that you want to apply the password lock to.

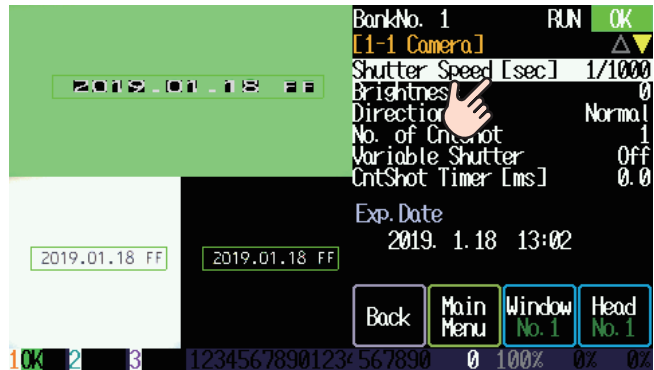

The setting is displayed in blue and the setting is set as a lock target item.

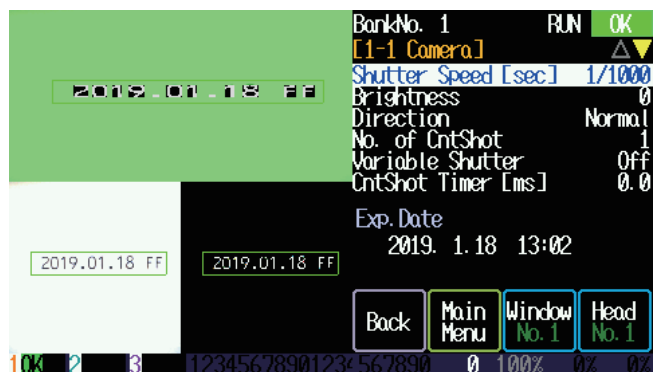

### MEMO

To clear this setting, touch the item again while pressing .

## 7-3-3 Apply the Password Lock

Apply the password lock on the target items.

- 1 On the [Main Menu] screen, touch [System].

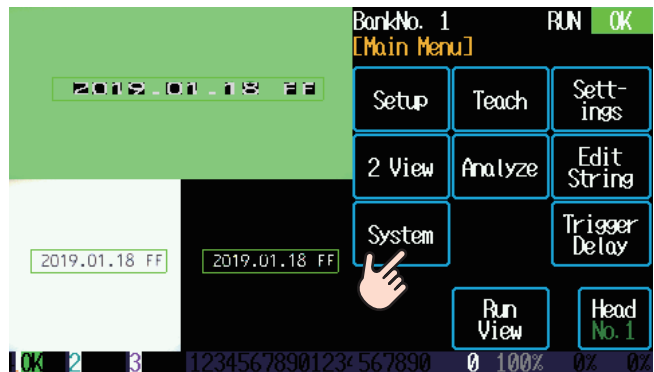

- 2 On the [System] screen, touch [Password Lock].

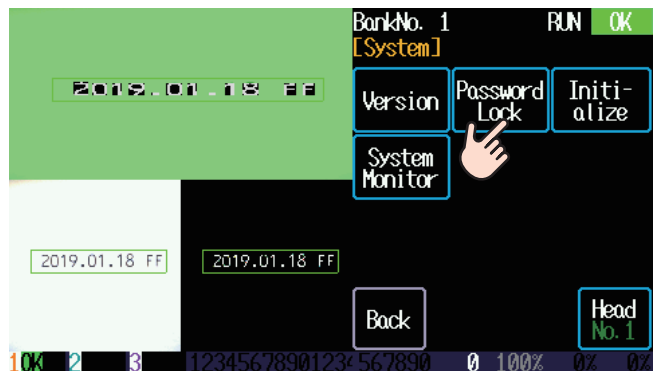

- 3 Touch [Lock/Unlock].

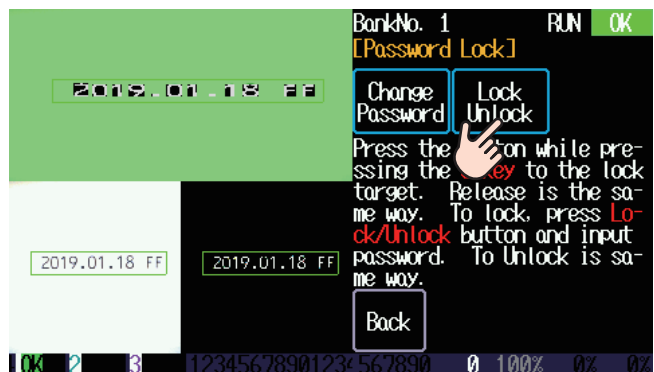

- 4 Enter the set password.



## 5 Touch [OK].

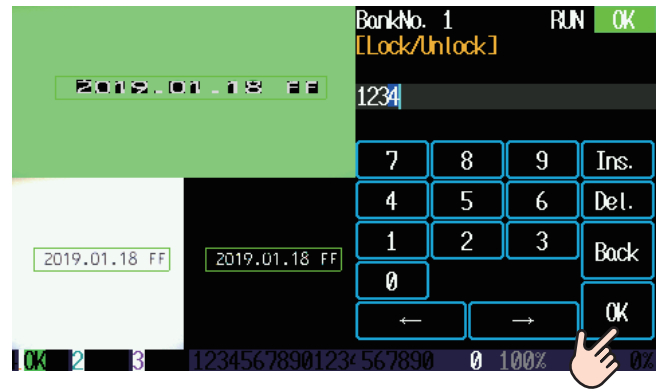

The items are locked.

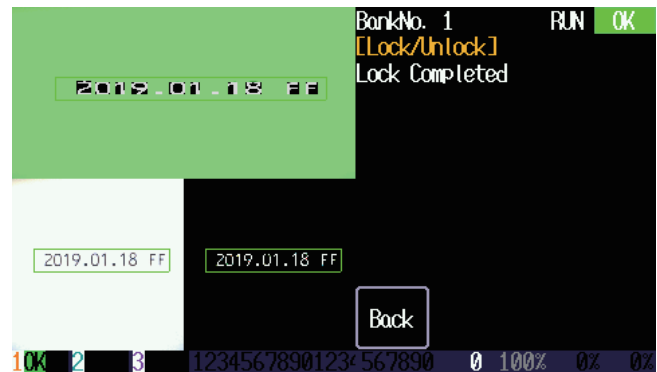

To unlock the items, on the [Password Lock] screen, touch [Lock/Unlock], and then follow this procedure from step 4.

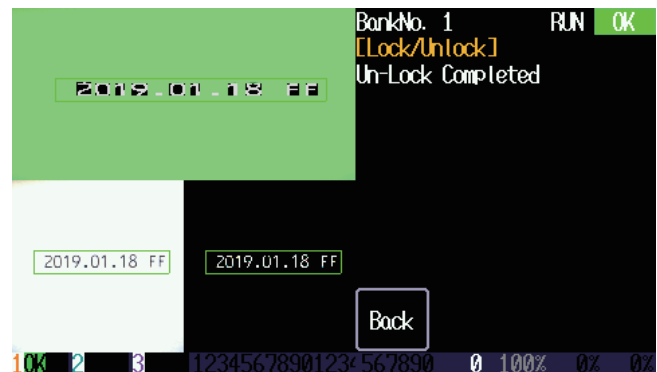

## Force release the password lock

If you turn on the controller while pressing the  key, the password lock will be force released.

Use this function when you have forgotten the password.

If you have forgotten the password, you can also initialize it by touching and holding [Change Password] or [Initialize] (to perform a complete initialization).

# 7-4 Change the Display Language

You can switch the touch panel display language to English, Japanese, Simplified Chinese, or Portuguese. The available display languages will vary depending on the version of the product begin used.

## MEMO

The first time that the device starts, the screen shown below in step **1** will be displayed.

- 1 Turn on the device while pressing the  key.**  
The display language selection screen is displayed.



- 2 Touch a language option.**  
The selected display language will be highlighted.



- 3 Touch [OK].**  
The device will start with the selected display language.



# 7-5 Monitor the Operating Environment of the Camera Unit

Monitor the internal temperature, input voltage, and current date and time of the camera unit.

- 1 On the [Main Menu] screen, touch [System].

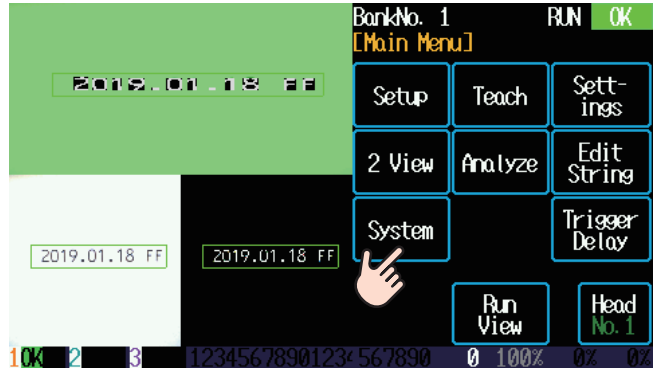

- 2 On the [System] screen, touch [System Monitor].

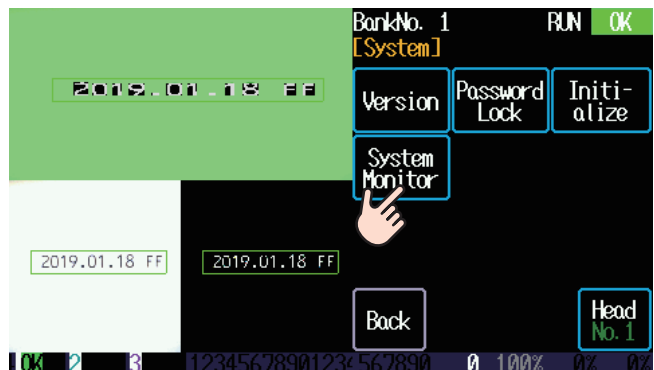

The screen displays the internal temperature, input voltage, and current date and time of the camera unit.

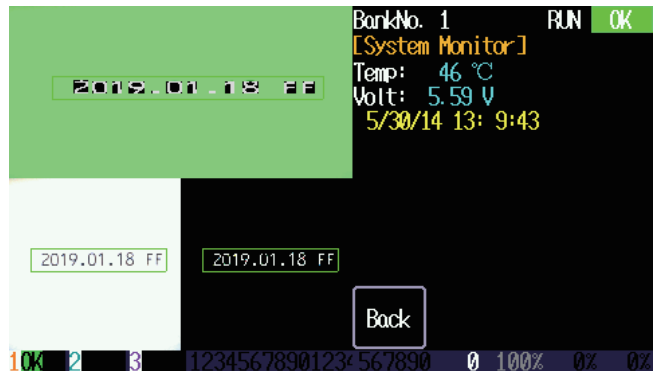

If the communication status indicator of the camera unit is not lit in green, the error details are displayed.

Example of the screen when an error occurs



# 7-6 Share the Recognized Character String of a Camera Unit

You can share the character string recognized by the master camera unit with the other camera units that are connected to the controller.

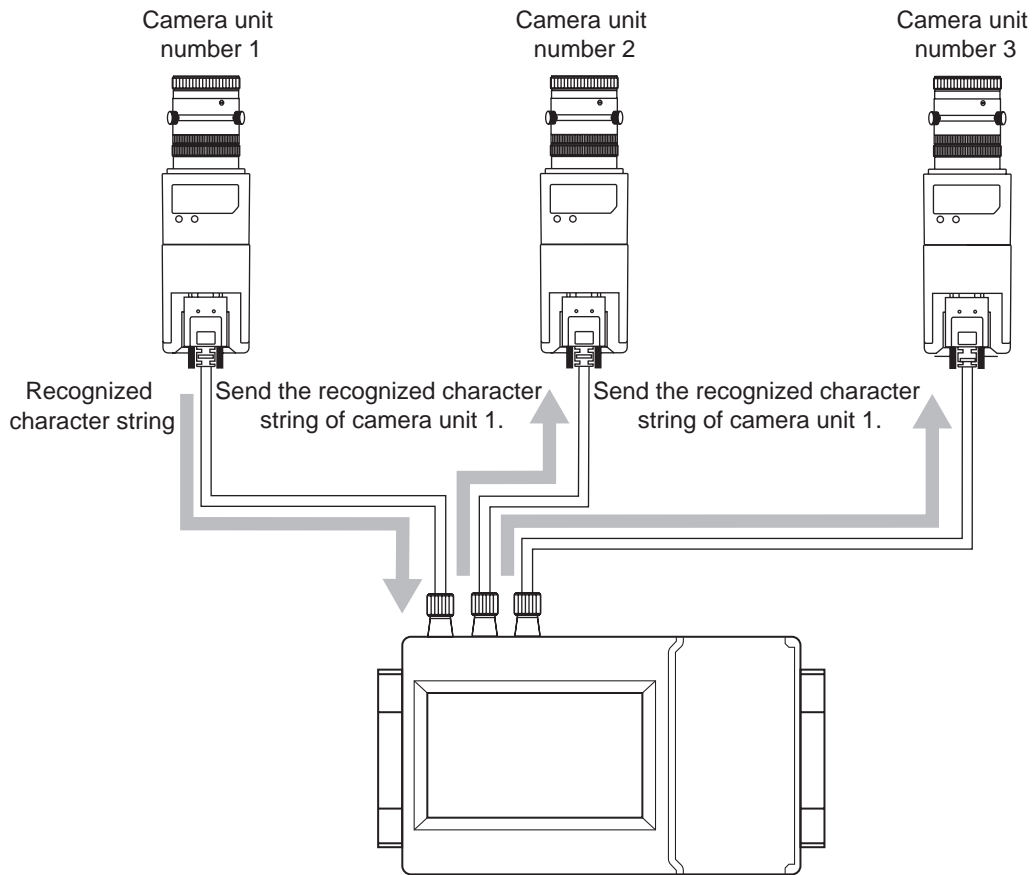

To use this function, touch [Settings], [Etc.] and configure the following settings.

- Verify Char Head
- Verify Char Send
- Verify Char Store

For details on the settings, see "6-11 Other Settings" (page 6-69).

# 7-7 The Barcode Link Function

To use a barcode reader with the controller, connect the barcode reader to the controller and use the "barcode link function" to link the operation of the barcode reader with that of the controller.

## 7-7-1 Steps for Using the Barcode Link Function

The barcode link function has two modes: standard mode and mixed-product inspection mode. The operating procedures for each mode during barcode verification are shown below.

### ■ Standard mode

#### (1) Barcode reading

The read results from the barcode reader are received by the controller through RS-232C communication.

Operation example

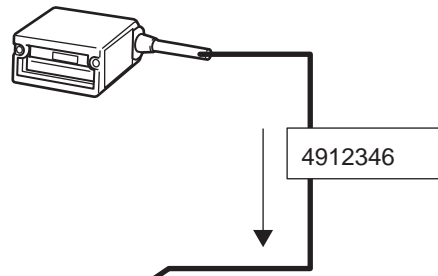

Verification table

1	2	3	4
4912345	4912346	4912347	4912348
• Head 1	• Head 1	• Head 1	• Head 2
• Bank 1	• Bank 2	• Bank 3	• Bank 2
• Output 1: ON	• Output 2: ON	• Output 3: ON	• Output 4: ON

#### (2) Verification

The read data is verified against the verification table to check which entry in the table matches the read data.

#### (3) Output

Operation commands are executed based on the settings.

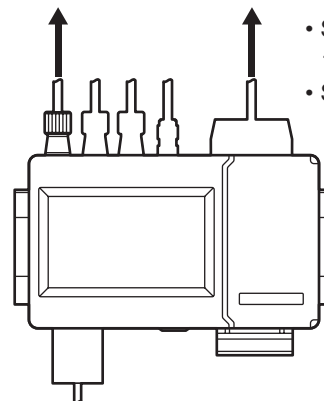

- Switch the bank of head 1 to "2."
- Set output "2" to ON.

## Mixed-product inspection mode

### (1) Reading of a correct product

The correct product is set from among those products in the verification table on the previous page.

#### Operation example

No.	Data
2	4912346

Set this as the correct product.

### (2) Barcode reading

The reading results of the barcode reader are received by the controller through RS-232C communication.

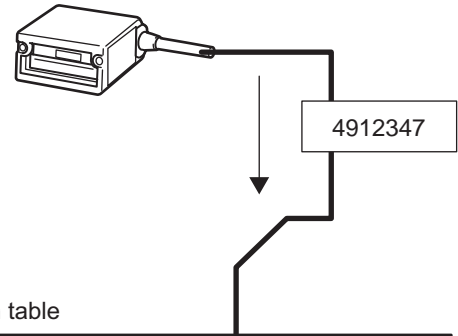

### (3) Verification

The read data is verified against the verification table to check that the read data matches the registered number ("2" in the example on the right).

Verification table

1	2	3	Failure
4912345	4912346	4912347	
• Output 1: ON	• Head 1 • Bank 2 • Output 2: ON	• Head 1 • Bank 3 • Output 3: ON	• Output 4: ON

The number is not "2," so ...

• Set output "4" to ON.

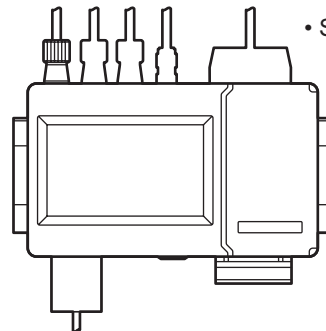

### (4) Output

Output is generated based the settings.

OK:

The details of table number 1 are output.

NG:

The terminal set with "No Match Out" is set to ON.

## 7-7-2 Controller I/O and the Barcode Link Function

The controller I/O when using the barcode link function is shown below.

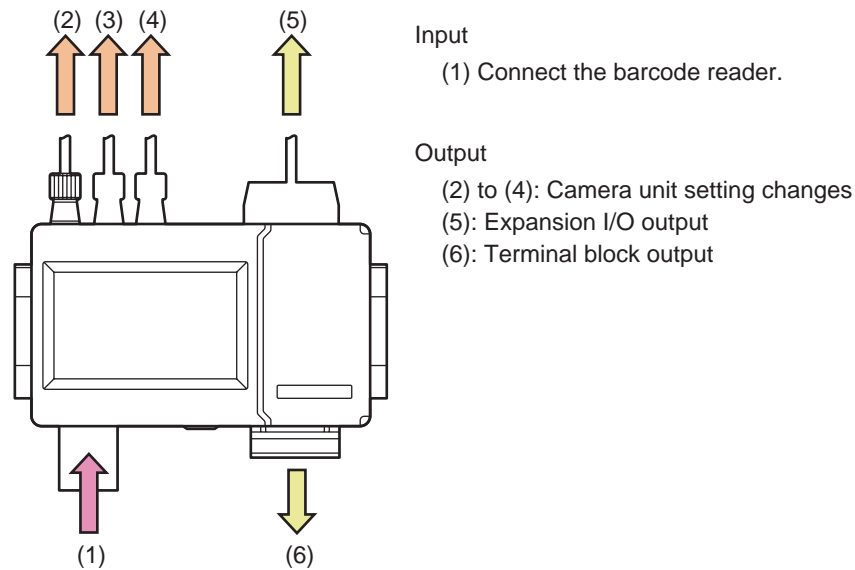

### ■ Camera unit settings changes ((2) to (4) in the above figure)

You can change the following camera unit settings.

- The head to use to read data
- The bank to use to read data
- The inspection window to use to read data
- The data read by the barcode reader (by sending the read details)

### ■ Expansion I/O output ((5) in the above figure)

You can generate output from the expansion I/O outputs (EY1 to EY20) based on the settings.

#### Caution

When you set expansion I/O for the barcode verification result output, any settings where expansion I/O outputs are used by the camera unit, such as ready output or busy output, cannot be used. (You can configure the settings, but they may not operate correctly.)

### ■ Terminal block output ((6) in the above figure)

Terminals with camera units not connected can be used as output terminals for verification results depending on the settings.

#### Caution

You may not be able to use the terminal block to generate barcode verification results. For example, if a camera unit is connected to head 1 of the controller, "OK1" and "NG1" of the terminal block will be used by the camera unit, so these terminals cannot be used to generate output to the barcode side.

## 7-7-3 Controller Verification Tables

The controller has two tables for receiving and verifying barcode data.

### ■ Data table image

Use the main unit touch panel to set table (1) and a computer to set table (2).

Verification is performed first with table (1) and then with table (2).

If no matching data is found in the tables, the "No Match" operation is performed.

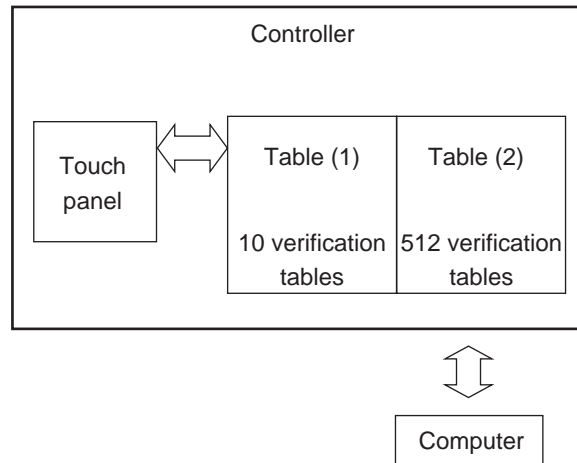

### Data table differences

Item	Table (1)	Table (2)
Number of verification tables	10	512
Checking and editing of table details from the touch panel	Yes	No
Checking and editing of table details from software on a computer	No	Yes
Support for verification in mixed-product inspection mode	Yes	No
Verification order	1	2
Verification time	8 ms maximum	100 ms maximum

### MEMO

To use table (2), "MVS-DN Table Editing Software" is required.

"MVS-DN Table Editing Software" can be downloaded from the Optex FA website free of charge.

## 7-7-4 Controller Timing Charts

The controller timing charts when using the barcode link function are shown below.

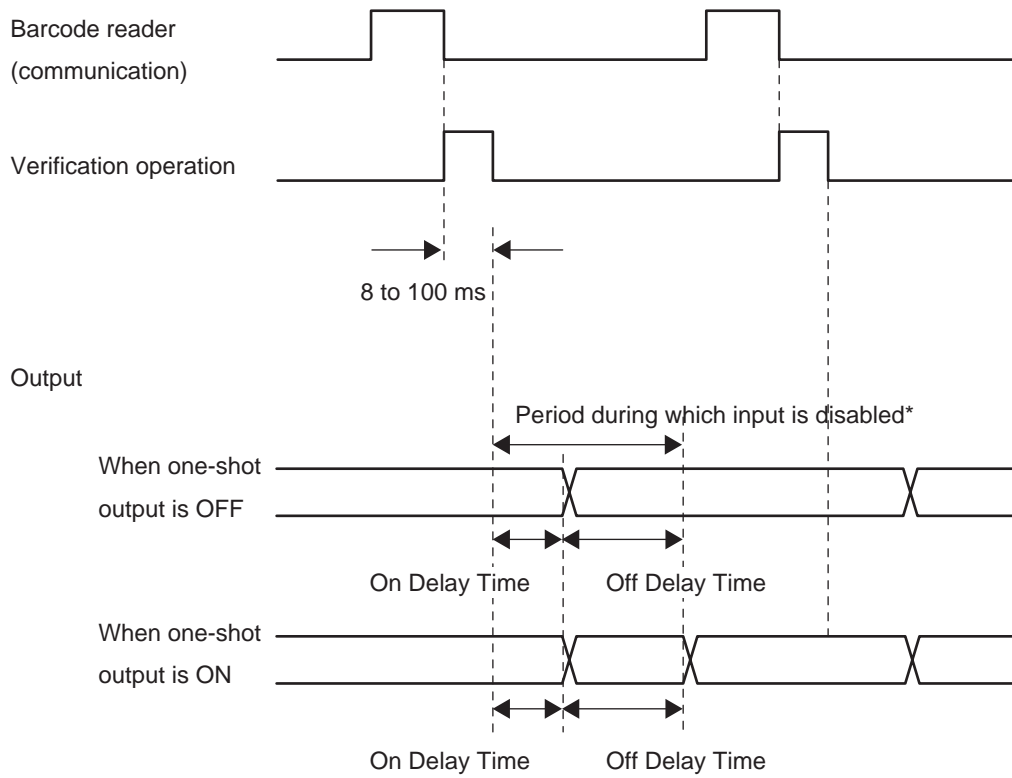

\* During this period, any new verification results that are received will be ignored. (They will not be output.)

## 7-7-5 Barcode Link Function Operation Screen

If you set the [Barcode Link] setting to "ON" on the barcode link function settings screen (page 7-22), you will be able to display the operation screen of the barcode link function.

### ■ Switching to the barcode link function operation screen

You can switch the display to the operation screen of the barcode link function from the operation screen of the controller.

Use the [Head No. X] key in the lower-right corner of the screen to switch between the display of the connected heads in order.

Camera unit operation screen



Operation screen of the barcode link function



## ■ Details of the barcode link function operation screen



Number	Name	Details
1	Terminal block output status	Displays the output status of the (12-pin) terminal block. OK: Green NG: Red When a camera unit is connected, the camera unit output is given priority. Connectors connected to camera units appear dimmed. (In the above example, the OK1, NG1, OK2, and NG2 connectors appear dimmed.)
2	Expansion I/O output status	Displays the output status of the (50-pin) expansion I/O connector. Terminals EY1 to EY20 that are generating output are displayed in yellow.
3	Barcode data	Displays details of the read barcode data.
4	Verification result	Displays the verification result. Displays "No Match" when the data cannot be verified. Displays the verification table number as shown in the following figure when the data can be verified.  <div style="text-align: center;">  </div>
5	Output status display	Displays the actual output status.
6	MVS-D Setting	Touch this key to set the controller.
7	B-Code Table Setting	Touch this key to switch to the "Barcode Table" screen for editing verification table (1). See "7-7-10 How to Set Verification Tables (Table (1))" (page 7-25).
8	Head	Touch this key to display the screen of the connected camera unit.

## 7-7-6 Mixed-product Inspection Mode Display

During mixed-product inspection mode, the verification results are displayed as shown below.



Active Table No. 3 Match

When the verification passes  
(when the number 3 barcode is read)

Active Table No. 3 No Match

When the verification fails  
(when a barcode other than the number 3 barcode is read)



Table number 1 of the currently selected table (1) is displayed.

## 7-7-7 Use External Input to Switch between Registration and Verification

You can use the external input terminals to switch between registration and verification of barcodes.

### ■ Cases in which external input is useful

External input is useful when you are checking for the mixing of products and in other similar situations where there is one barcode to verify and you frequently perform registrations.

### ■ Enabling external input

To enable external input, set to ON the terminal that "Change Table IN" has been set to on the main unit settings screen.

### ■ Operation of external input

You can switch the operation by setting to ON or OFF the terminal that "Change Table IN" has been set to.

#### ● When the terminal is set to OFF (verification)

The read barcode data is verified against the verification table.

#### ● When the terminal is set to ON (registration)

The details of the read barcode data are registered to number 1 of verification table (1). Verification table (1) can be checked from the touch panel.

## 7-7-8 Using Terminal Input to Switch the Target Table

You can use terminal input to switch the target verification table number during mixed-product inspection mode.

Use up to four terminals for verification. Use the settings to specify the terminals to be used.

Table number	Expansion I/O input EX or T			
	N	N + 1	N + 2	N + 3
1	OFF	OFF	OFF	OFF
2	<b>ON</b>	OFF	OFF	OFF
3	OFF	<b>ON</b>	OFF	OFF
4	<b>ON</b>	<b>ON</b>	OFF	OFF
5	OFF	OFF	<b>ON</b>	OFF
6	<b>ON</b>	OFF	<b>ON</b>	OFF
7	OFF	<b>ON</b>	<b>ON</b>	OFF
8	<b>ON</b>	<b>ON</b>	<b>ON</b>	OFF
9	OFF	OFF	OFF	<b>ON</b>
10	<b>ON</b>	OFF	OFF	<b>ON</b>

## 7-7-9 Controller Settings

When you use the barcode link function, change the controller settings.

### Barcode link function settings

If you turn the power on while pressing , the main unit settings screen [MVS-D Setting] shown below is displayed.

#### MEMO

You can also display the main unit settings screen [MVS-D Setting] by touching [MVS-D Setting] on the operation screen of the barcode link function.

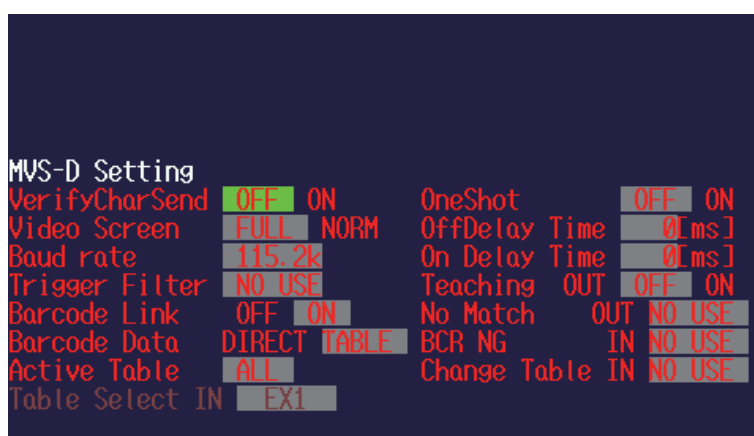

### Setting Details

Setting	Value (Values in bold are default values.)	Function
VerifyCharSend	OFF, ON	Set this to "OFF" during verification.
Video Screen	FULL, NORM	Do not change this setting value from "FULL."
Baud rate	<b>9600</b> , 19200, 38400, 57600, 115.2k, 250k, 312.5k, 500k	Change the baud rate for RS-232C communication with the barcode reader. The communication specifications are fixed to the values shown below. <ul style="list-style-type: none"> <li>• Data length: 8 bits</li> <li>• Parity: None</li> <li>• Number of stop bits: 1</li> </ul>
Trigger Filter	<b>100μs</b> , 400μs, 1ms, 5ms, 10ms, 30ms, 50ms, NO USE	If noise leads to incorrect trigger signals to the camera when [BCR NG IN] is in use, you can prevent these incorrect signals by applying a time filter (this setting is valid for T11, T12, and T13).
Barcode Link	OFF, ON	Set this to "ON" when a barcode reader is connected. When set to "ON," you can use the barcode link function under the following conditions without pressing  when the device turns on. <ul style="list-style-type: none"> <li>• When camera units are connected</li> </ul> You can switch the screen by touching [Head No. X] (on the camera unit operation screen) or [Head] (on the barcode link function operation screen). <ul style="list-style-type: none"> <li>• When no camera units are connected</li> </ul> When the device turns on, it will start with the barcode link function operation screen displayed.

Setting	Value (Values in bold are default values.)	Function
Barcode Data* <sup>1</sup>	<b>DIRECT</b> , TABLE	Select the method to process data from the barcode reader. If you select "TABLE," [OneShot] and all subsequent setting values will be enabled. "DIRECT:" Barcode reader data will be sent to the camera unit as the read character string. "TABLE:" Barcode reader data will be verified using the verification table.
Active Table	<b>ALL</b> , No.1 to No.10, <b>INPUT</b>	Select the verification target. Values other than "ALL" can be used in mixed-product inspection mode. "ALL:" Normally select this value (standard mode). "No.1" to "No.10:" The set table number is used as the verification target. "INPUT:" The table number set with the terminal is set as the verification target.
Table Select IN	<b>EX1</b> to EX10, T11, T12, T13	When [Active Table] is set to "INPUT," specify the terminal to use.
OneShot	<b>OFF</b> , ON	Select whether to perform one-shot operations.
OffDelay Time	<b>0</b> to 9999	Set the off-delay time (ms). To set this value, set [OneShot] to "ON."
On Delay Time	<b>0</b> to 9999	Set the on-delay time (ms). To set this value, set [OneShot] to "ON."
Teaching OUT* <sup>2</sup>	<b>OFF</b> , ON	If set to "ON," the reading results are output from the terminal block terminal or the expansion I/O terminal set with the string entered in the "Barcode" field when barcode reading or registration is performed on verification table number 1 of table (1). If you are using [Change Table IN] to perform registration for each barcode, the output of the reading results can be used as a substitute for the teaching completion signal.
No Match OUT	ALL OFF, OK1 to OK3, NG1 to NG3, EY1 to EY20, <b>NO USE</b>	Set which output is enabled when there is no data to match against the verification table. "ALL OFF:" All outputs will be set to OFF. "OK1" to "OK3" and "NG1" to "NG3:" Output is from the terminal block. "EY1" to "EY20:" Output is from an expansion I/O terminal. "NO USE:" No output.
BCR NG IN	EX1 to EX10, T11 to T13, <b>NO USE</b>	Select the terminal to connect to the NG signal wire of the barcode reader. When the NG signal is ON, the output set with [No Match OUT] will be performed. "EX1" to "EX10:" Input is received from an expansion I/O terminal. "T11" to "T13:" Input is received from the terminal block. "NO USE:" No output.
Change Table IN	EX1 to EX10, T11 to T13, <b>NO USE</b>	If reading is performed while the set terminal input is ON, the read barcode data will be registered to verification table number 1 of table (1). "EX1" to "EX10:" Input is received from expansion I/O. "T11" to "T13:" Input is received from the terminal block. "NO USE:" No output. For details, see "7-7-7 Use External Input to Switch between Registration and Verification" (page 7-20).

For details on the operation of the "OneShot," "On Delay Time," and "OffDelay Time" settings, see "7-7-4 Controller Timing Charts" (page 7-17).

\*1 If the reading result of the barcode reader does not generate any matches in the verification tables, even if you specify TABLE mode, only when the "String" recognition format is in use for inspection window 1 of the camera unit will the reading result be sent to the verification character string.

You can use the following methods to prevent this.

(1) If you are using a controller that has an FPGA version earlier than 000D and a software version earlier than 2010/11/10

If you are using a verification table that you can set from the controller, set the "Barcode" field of table number 10 to the "?" character. If you are using the table editing software, set the "Barcode Details" cell of table number 512 to the "?" character. Do not set the "String" field to anything. "?" is a wildcard character, so the details of the reading results will always generate a match. Also, leaving the "String" field empty, where the command to be executed is stored, you can stop the verification operation at this wildcard character.

(2) If you are using a controller that has FPGA version 000D or later and software version 2010/11/10 or later

By setting the "No Match OUT" output, you can eliminate the above problem by cancelling the sending of reading results to the camera unit.

\*2 Output will be performed even if "NoRead" or other error results are entered as the reading results in the "Barcode" field. This is not a signal that means reading has finished normally. Also, the signal output here is the same as the verification results output of verification table number 1 of table (1) during operation.

Normally, set this to "OFF" when you are not using [Change Table IN].

---

## MEMO

You can confirm the FPGA version and software version of the controller on the screen displayed when the controller turns on.

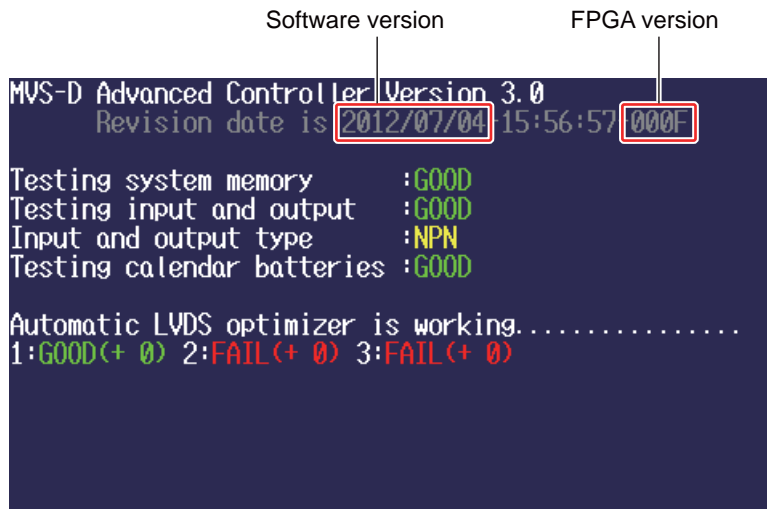

This screen is only displayed temporarily when the barcode link function is set to "ON" or when a camera unit is connected to the controller. If it is difficult for you to check the display, set the barcode link function to "OFF," turn the power off, remove the camera unit, and then turn the power on again. The device will stop at the above screen.

To restart the device after you have checked the versions, be sure to turn the power off, connect the camera unit, turn the power on again while pressing the  key, and then set the barcode link function back to "ON."

## 7-7-10 How to Set Verification Tables (Table (1))

To view or change table (1), touch [B-Code Table Setting] on the barcode link function operation screen to display the screen for viewing and setting verification tables.

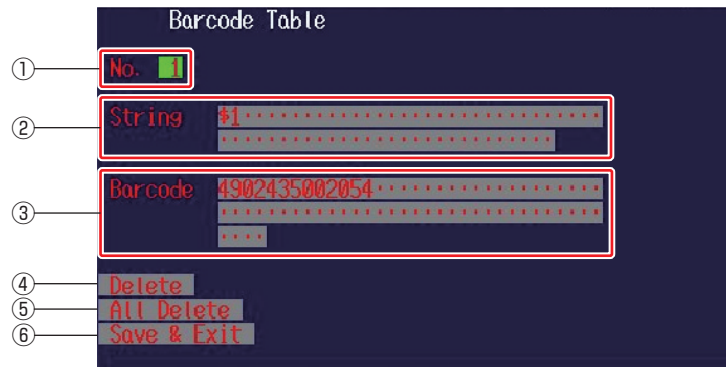

Number	Name	Function
1	Table number	There are 10 tables numbered from 1 to 10.
2	String	Enter the command to use during verification. For the input specifications, see "7-7-11 List of Controller Commands" (page 7-26).
3	Barcode	Enter the details of the barcode to verify. Entered content will be used for a prefix search. When you perform reading with the connected barcode reader, this screen is populated with the read details.
4	Delete	Touch this key to delete the details of the displayed table.
5	All Delete	Touch this key to delete all the details of table (1).
6	Save & Exit	Touch this key to save the set details and exit.

## 7-7-11 List of Controller Commands

The commands used to control operations in standard mode are shown below.

You can use these commands when you select the "Custom" check box in the table editing software.

These commands are displayed in the converted character strings of "OCRBarcodeTable.exe."

Also, enter these commands in the "String" field of table (1).

### ■ Character format

Format: ABBBBCCCCC

A: Control command (no character or one character)

B: Command details (one to four characters depending on the control command)

C: Character string to send (arbitrary)

### ■ Control commands

- Connected head specification (heads 1 + 2 + 3 when this command is not specified)

Format: &A

A: Head number (one character, see the following table)

Head number	Sent character A
1	6
2	5
3	4
1 + 2	3
1 + 3	2
2 + 3	1
1 + 2 + 3	0

- Head bank switching

Format: !A

A: Head bank number (one character, see "Table of characters sent when switching the bank")

- Window number specification ("1" when this command is not specified)

Format: "A

A: Window number (one character)

- Sending read barcode data to the camera unit

Format: #AB

A: Send start position (one character, see "Table of characters sent when specifying the number of characters")

B: Send end position (one character, see "Table of characters sent when specifying the number of characters")

## ■ Command input examples

By combining commands, you can perform multiple operations and send to the camera unit a part of the barcode reader's reading results.

**(1) Setting the OK1 (T11) terminal of the (12-pin) terminal block to ON**

Command: \$1

**(2) Setting the OK3 (T13) terminal of the (12-pin) terminal block and the EY1 terminal of the expansion I/O connector to ON**

Command: \$4%1000

**(3) Changing camera head 1's bank to 3**

Command: &6!2

**(4) Sending 2nd to 10th characters of the read characters to camera unit 2**

Command: &5#2

• Table of characters sent when specifying the number of characters

Number of characters	Sent character
1	1
2	2
3	3
4	4
5	5
6	6
7	7
8	8
9	9
10	:
11	;
12	<
13	=
14	>
15	?
16	@
17	A

Number of characters	Sent character
18	B
19	C
20	D
21	E
22	F
23	G
24	H
25	I
26	J
27	K
28	L
29	M
30	N
31	O
32	P
33	Q
34	R

Number of characters	Sent character
35	S
36	T
37	U
38	V
39	W
40	X
41	Y
42	Z
43	[
44	
45	]
46	^
47	_
48	`
49	a
50	b
51	c

Number of characters	Sent character
52	d
53	e
54	f
55	g
56	h
57	i
58	j
59	k
60	l
61	m
62	n
63	o
64	p
65	q
66	r
67	s
68	t

• Table of characters sent when switching the bank

Bank number	Sent character
1	0
2	1
3	2
4	3
5	4
6	5
7	6
8	7
9	8
10	9
11	:
12	;
13	<
14	=
15	>
16	?
17	@

Bank number	Sent character
18	A
19	B
20	C
21	D
22	E
23	F
24	G
25	H
26	I
27	J
28	K
29	L
30	M
31	N
32	O

- Judgment output (terminal block) settings

Format: \$A

A: Output code (see the following tables)

Output terminal name						Sent character
OK1	NG1	OK2	NG2	OK3	NG3	
X	X	X	X	X	X	0
O	X	X	X	X	X	1
X	O	X	X	X	X	2
O	O	X	X	X	X	3
X	X	O	X	X	X	4
O	X	O	X	X	X	5
X	O	O	X	X	X	6
O	O	O	X	X	X	7
X	X	X	O	X	X	8
O	X	X	O	X	X	9
X	O	X	O	X	X	:
O	O	X	O	X	X	;
X	X	O	O	X	X	<
O	X	O	O	X	X	=
X	O	O	O	X	X	>
O	O	O	O	X	X	?
Output terminal name						Sent character
OK1	NG1	OK2	NG2	OK3	NG3	
X	X	X	X	X	O	@
O	X	X	X	O	X	A
X	O	X	X	O	X	B
O	O	X	X	O	X	C
X	X	O	X	O	X	D
O	X	O	X	O	X	E
X	O	O	X	O	X	F
O	O	O	X	O	X	G
X	X	X	O	O	X	H
O	X	X	O	O	X	I
X	O	X	O	O	X	J
O	O	X	O	O	X	K
X	X	O	O	O	X	L
O	X	O	O	O	X	M
X	O	O	O	O	X	N
O	O	O	O	O	X	O
Output terminal name						Sent character
OK1	NG1	OK2	NG2	OK3	NG3	
X	X	X	X	X	O	P
O	X	X	X	X	O	Q
X	O	X	X	X	O	R
O	O	X	X	X	O	S
X	X	O	X	X	O	T
O	X	O	X	X	O	U
X	O	O	X	X	O	V
O	O	O	X	X	O	W
X	X	X	O	X	O	X
O	X	X	O	X	O	Y
X	O	X	O	X	O	Z
O	O	X	O	X	O	[
X	X	O	O	X	O	
O	X	O	O	X	O	]
X	O	O	O	X	O	^
O	O	O	O	X	O	_
Output terminal name						Sent character
OK1	NG1	OK2	NG2	OK3	NG3	
X	X	X	X	O	O	`
O	X	X	X	O	O	a
X	O	X	X	O	O	b
O	O	X	X	O	O	c
X	X	O	X	O	O	d
O	X	O	X	O	O	e
X	O	O	X	O	O	f
O	O	O	X	O	O	g
X	X	X	O	O	O	h
O	X	X	O	O	O	i
X	O	X	O	O	O	j
O	O	X	O	O	O	k
X	X	O	O	O	O	l
O	X	O	O	O	O	m
X	O	O	O	O	O	n
O	O	O	O	O	O	o

- Expansion output (expansion I/O connector) settings

Format: %ABCD

A: Output code of expansion output numbers 1 to 5 (see the following tables)

B: Output code of expansion output numbers 6 to 10 (see the following tables)

C: Output code of expansion output numbers 11 to 15 (see the following tables)

D: Output code of expansion output numbers 16 to 20 (see the following tables)

	Terminal number					Sent character
	1	2	3	4	5	
Terminals 1 to 5	1	2	3	4	5	
Terminals 6 to 10	6	7	8	9	10	
Terminals 11 to 15	11	12	13	14	15	
Terminals 16 to 20	16	17	18	19	20	
	X	X	X	X	X	0
	O	X	X	X	X	1
	X	O	X	X	X	2
	O	O	X	X	X	3
	X	X	O	X	X	4
	O	X	O	X	X	5
	X	O	O	X	X	6
	O	O	O	X	X	7
	X	X	X	O	X	8
	O	X	X	O	X	9
	X	O	X	O	X	:
	O	O	X	O	X	:
	X	X	O	O	X	<
	O	X	O	O	X	=
	X	O	O	O	X	>
	O	O	O	O	X	?

	Terminal number					Sent character
	1	2	3	4	5	
	6	7	8	9	10	
	11	12	13	14	15	
	16	17	18	19	20	
	X	X	X	X	O	@
	O	X	X	X	O	A
	X	O	X	X	O	B
	O	O	X	X	O	C
	X	X	O	X	O	D
	O	X	O	X	O	E
	X	O	O	X	O	F
	O	O	O	X	O	G
	X	X	X	O	O	H
	O	X	X	O	O	I
	X	O	X	O	O	J
	O	O	X	O	O	K
	X	X	O	O	O	L
	O	X	O	O	O	M
	X	O	O	O	O	N
	O	O	O	O	O	O

# 7-7-12 Barcode Link Function Setting Example

## ■ Setting the barcode verification

This section explains the settings required for registering barcodes independent of the device (performing teaching) and verifying and judging barcodes.

The operations in this usage method are as follows: a teaching start signal is applied to the controller from an external source, the controller switches to the barcode receiving status, and then the controller makes the device read the barcode to complete the registration.

### ● MEMO

Only data table (1) can be used in the registration with this operation.

## ● Teaching start signal input terminals

The following terminals can be used.

### Terminal block

Pin number	Terminal name
5	T11
8	T12
11	T13

### Expansion I/O connector

Pin number	Terminal name
16 to 25	EX1 to EX10

T11 is used as a setting example in this section. The teaching start signal must hold the ON status until teaching is finished.

## ● Verification result output terminals

In this section, the verification results are output from the expansion I/O connector as shown below.

Judgment details	Pin number	Terminal name	Output operation
The registered details and the read barcode match (OK judgment).	1	OK1	ON for 1 second
The registered details and the read barcode do not match (NG judgment).	2	NG1	

## ● Setting procedure

**1** Connect the teaching start signal wire to T11 (pin number 5) of the lower terminal block of the controller.

**2** On the barcode link function operation screen, touch **[MVS-D Setting]**.

The main unit settings ([MVS-D Setting]) screen is displayed.



### 3 Configure the main unit settings as shown below.

Touch each setting to configure it.

Settings	Details
OneShot	ON
OffDelay Time	1000 ms
NoMatch OUT	NG1
Change Table IN	T11

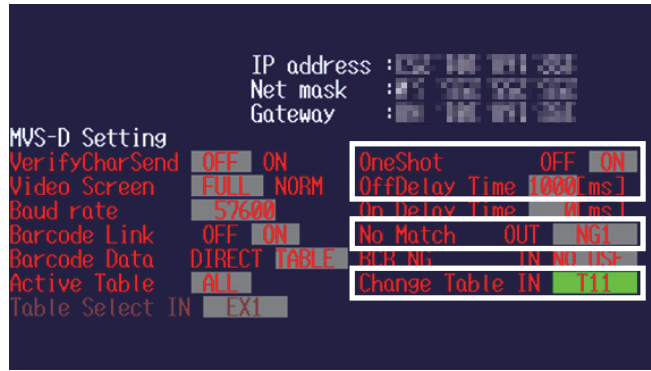

### 4 Press the **EXIT** key.

The device returns to the barcode link function operation screen.

### 5 On the barcode link function operation screen, touch **[B-Code Table Setting]**.

The display switches to the [Barcode Table] screen.



### 6 On the [Barcode Table] screen, touch the [String] field and enter "\$1."

"\$1" is the command for turning ON T11 of the terminal block.

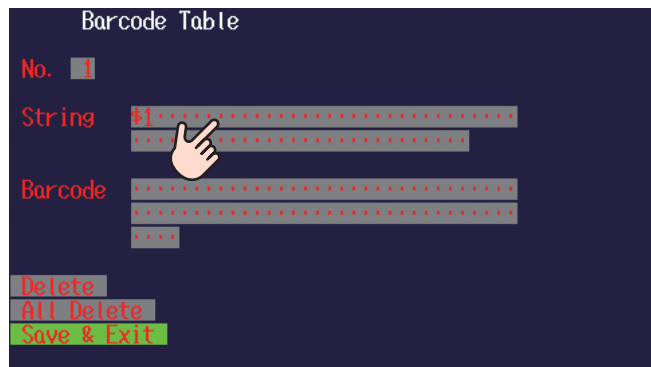

## MEMO

For details on the serial communication commands to enter in the [String] field, see "7-7-11 List of Controller Commands" (page 7-26).

### 7 Touch **[Save & Exit]**, and then press the **SET** key.

This completes the settings.

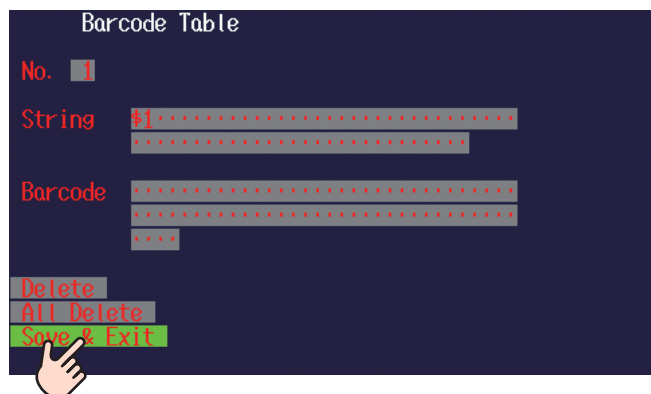

## ● Checking the barcode verification operation

- 1 Apply an ON signal to T11.  
The display switches to the [Barcode Table] screen.

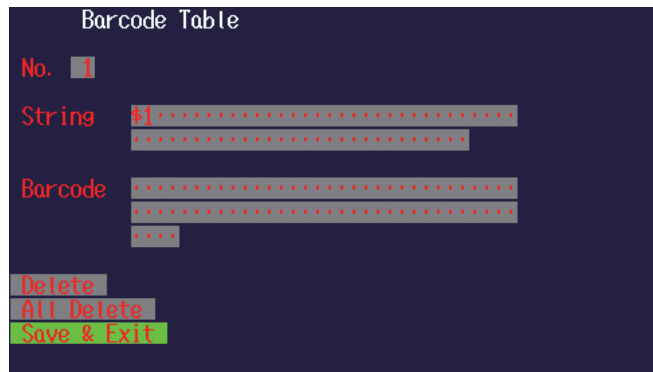

### ●●● MEMO ●●●

Hold the ON status for the T11 input until reading is finished.

- 2 Read a barcode with the barcode reader.

The details of the read barcode are displayed in the [Barcode] field. When the barcode reading is finished, the reading reception status is cleared.

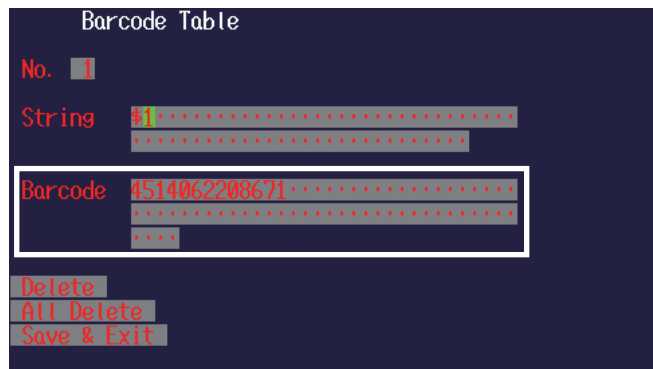

## ■ Selecting the bank by reading a barcode

Configure the settings to select the bank by reading a barcode.

In this section, as an example, the settings are configured to identify three types of products with barcodes and to automatically switch between banks with different settings and perform inspections.

Product	Barcode details	Bank number
A	ABCDEF123	Number 5
B	ABCDEF456	Number 10
C	ABCDEF789	Number 15

## ● Changing the bank selection method

- 1 On the [Main Menu] screen, touch [Settings].

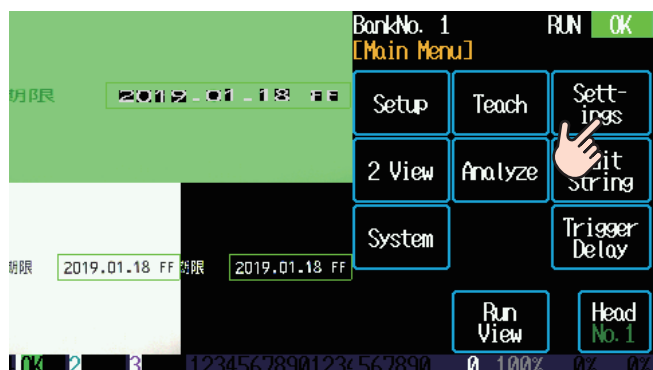

- On the [Settings] screen, touch [Input/Output].



- On the [4 Input/Output] screen, touch [Input].

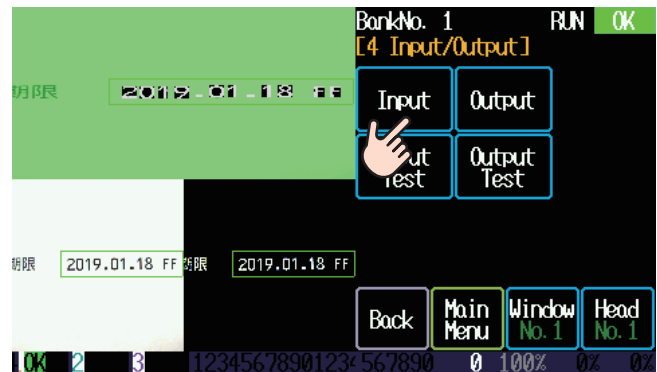

- Touch [Bank Select] and change the setting to [COMM].  
This setting makes it possible to select the bank using serial communication commands.

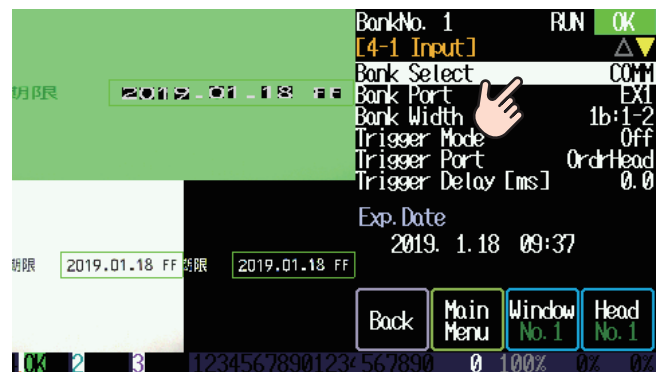

- Press the **EXIT** key.  
The display switches to the barcode link function operation screen.  
Continue by setting the bank number to switch to according to the details of the read barcode.

● **Linking the barcode details and the bank number**

**1** On the barcode link function operation screen, touch **[B-Code Table Setting]**.  
The display switches to the [Barcode Table] screen.



**2** On the [Barcode Table] screen, touch the [String] field and enter “&6!4.” “&6!4” is a command for changing the bank of camera head 1 (&6) to bank number 5 (!4).

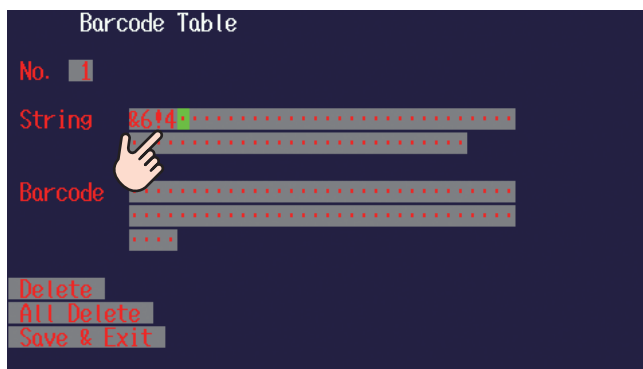

●●● MEMO ●●●

- For details on the serial communication commands to enter in the [String] field, see "7-7-11 List of Controller Commands" (page 7-26).
- When only one camera head is connected, you can omit the specification of the camera head from the above command. In this example, enter only "!4," the command for specifying the bank number.

**3** Read the barcode of product A with the barcode reader.



The details of the read barcode are displayed in the [Barcode] field. Check that “&6!4” is entered in the [String] field and “ABCDEF123” is entered in the [Barcode] field for table [No.] 1, and then proceed to the next step.

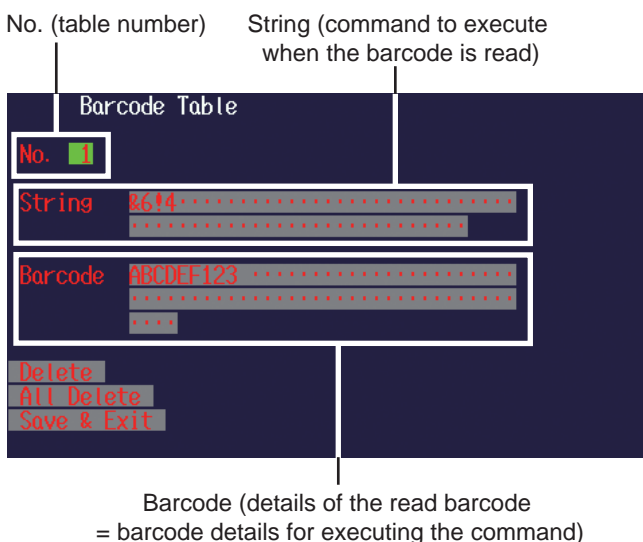

●●● MEMO ●●●

You can also touch the [Barcode] field and enter the barcode details directly.

**4** Touch the [No.] field, and then use the  key to change the table number to “2.”

- 5** Enter the following text in the [String] field, and then read the barcode of product B.  
[String]: &6!9 (Change the bank of camera head 1 (&6) to bank number 10 (!9)).

Product B barcode example



ABCDEF456

Check that “&6!9” is entered in the [String] field and “ABCDEF456” is entered in the [Barcode] field for table [No.] 2, and then proceed to the next step.

- 6** Touch the [No.] field, and then use the key to change the table number to “3.”

- 7** Enter the following text in the [String] field, and then read the barcode of product C.  
[String]: &6!> (Change the bank of camera head 1 (&6) to bank number 15 (!>)).

Product C barcode example



ABCDEF789

Check that “&6!>” is entered in the [String] field and “ABCDEF789” is entered in the [Barcode] field for table [No.] 3, and then proceed to the next step.

- 8** Touch [Save & Exit], and then press the key.

This completes the settings.

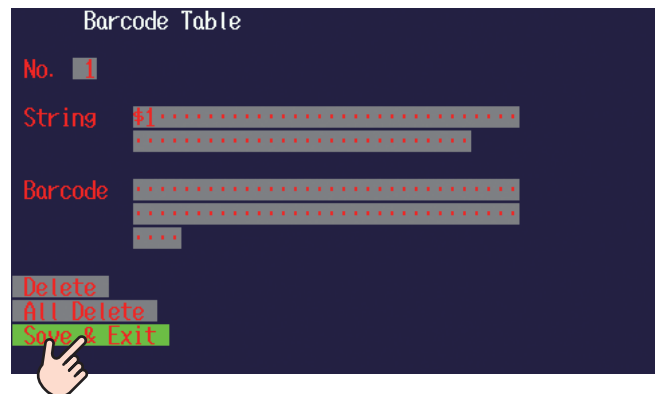

● **Checking bank selection by reading a barcode**

- 1** Return to the [Main Menu] screen, read the barcodes for products A, B, and C, and check that the bank is switched.

When the product A barcode is read  
(select bank number 5)



When the product B barcode is read  
(select bank number 10)



When the product C barcode is read  
(select bank number 15)





---

# 8

## **Configure Settings with Communication**

This chapter explains how to configure settings using RS-232C or Ethernet communication.

# 8-1 Specifications

This section explains the communication specifications.

## 8-1-1 Communication Specifications

The specifications for each protocol are shown below.

### ■ RS-232C communication specifications

Item	Details
Interface	RS-232C
Baud rate*	9600, 19200, 38400, 57600, 115200 (default value), 250000, 312500, 500000 bps
Data length	8 bits
Parity bit	None
Stop bit	1 bit
Master/slave	Slave
Protocol (reception)	Command + address (3 bytes) + number of words + number of additional replies
Protocol (reply)	ACK + number of words + data (length equivalent to the number of words) + checksum
Checksum	The least-significant 8 bits of the sum of the data from the command to the checksum.

\*You can only change the baud rate setting. Set the [Baud Rate] setting value—which is accessed by touching [Settings] and then [Etc.]. ("6-11 Other Settings" (page 6-69))

### ■ USB communication specifications

Item	Details
Standard	USB1.1

### ■ Ethernet communication specifications

Item	Details
Standard	10BASE-T/100BASE-TX
Communication protocol	TCP/IP
Number of connections	1
Cable	Use a Category 5 or higher cable. Straight through cables and crossover cables are both supported.

\* There are two Ethernet-compatible controller models: MVS-DN-E and MVS-DP-E.

## 8-1-2 RS-232C Wiring

Wire the target device as shown in the following figure.

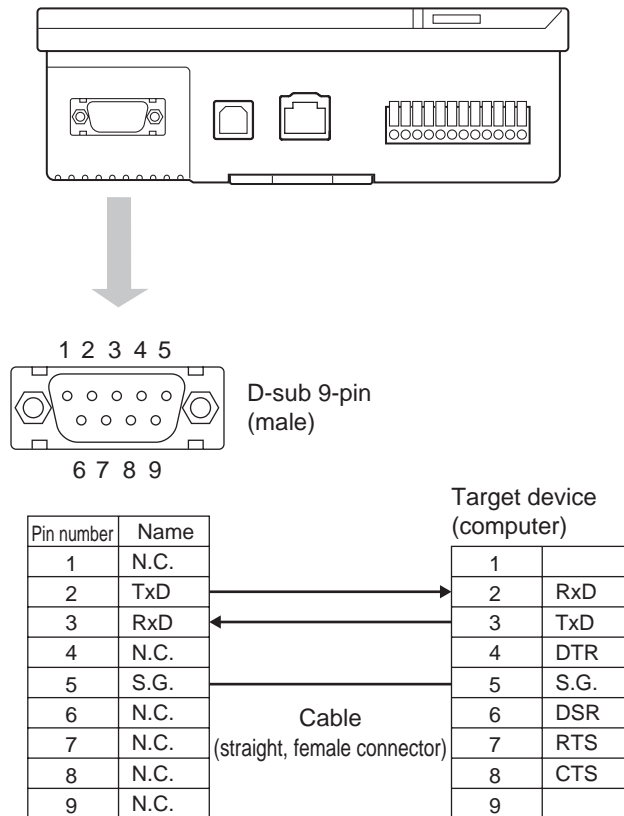

### MEMO

Wire other terminals according to the specifications of the target device.

## 8-1-3 Communication Commands

The communication commands that can be used on this device are shown below.

Command		Details	Reference page
0xE4	Barcode link ON command	Switch the bank	8-4
0x24	Barcode link OFF command		
0xE8	Barcode link ON command	Read the recognized character string	8-6
0x28	Barcode link OFF command		
0xE8	Barcode link ON command	Read the recognized character string and the match rate	8-9
0x28	Barcode link OFF command		
0xD4	Barcode link ON command	Write the reference string	8-11
0x14	Barcode link OFF command		
0xD0	Barcode link ON command	Read the reference string	8-15
0x10	Barcode link OFF command		
0x55	—	Switch to USB serial communication mode	8-18
0xFE	—	Cancel USB mode	8-18
0xF0	—	Set the calendar timer	8-19
0xF1	—	Read the calendar timer	8-20

### MEMO

- For controllers with the barcode link function (FPGA version "000C" or later and software version "2010/07/08" or later), use the "Barcode link ON" command when the barcode link function is on and the "Barcode link OFF" command when the barcode link function is off.  
If you are using a version of the controller with no barcode link function, be sure to use only the commands labeled as "Barcode link OFF command"  
\*For details on how to check the version of the controller, see Page 7-24.
- For the "Switching to USB serial communication mode," "Canceling USB mode," "Setting the calendar timer," and "Reading the calendar timer" commands, there is no difference between when the barcode link function is on or off.

## Switching the bank

Switch the specified head to the specified bank number.

### MEMO

To use communication to switch the bank, set [Bank Select]—which is accessed by touching [Settings], [Input/Output], and then touching [Input]—to "COMM."

### Send

When the barcode link function is on

Command	Bank number	Fixed	Mode	Number of words	Additional reply	Checksum
0xE4 + head number	0x00 to 0x1F	0x6A	0	0	0	Command to checksum

When the barcode link function is off

Command	Bank number	Fixed	Mode	Number of words	Additional reply	Checksum
0x24 + head number	0x00 to 0x1F	0x6A	0	0	0	Command to checksum

### Example of sending the command when barcode link function is off

Switching the bank number of the camera unit connected to head 1 to bank number "25"

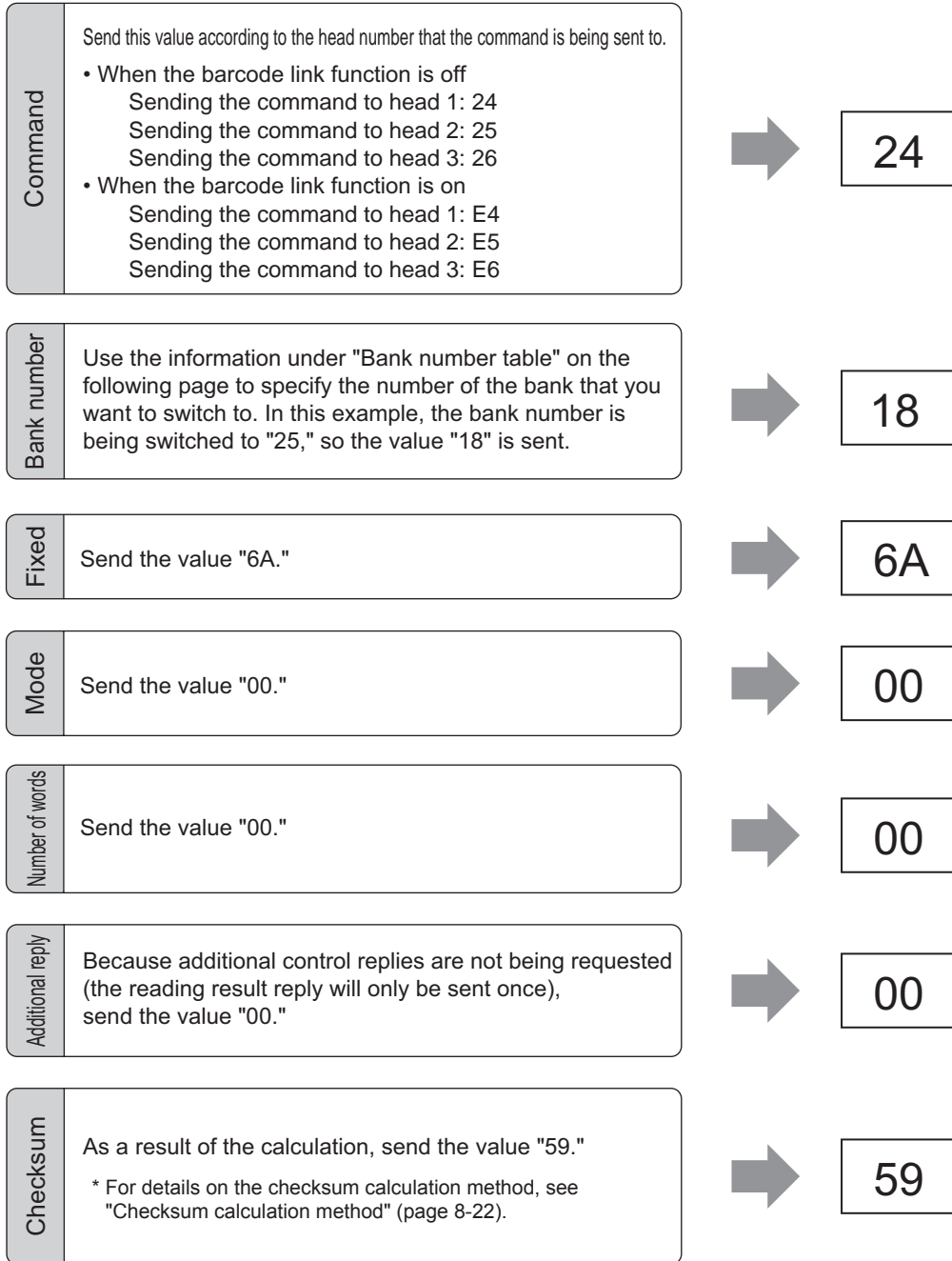

## Bank number table

Bank number	Hexadecimal	Bank number	Hexadecimal
Bank 1	00	Bank 17	10
Bank 2	01	Bank 18	11
Bank 3	02	Bank 19	12
Bank 4	03	Bank 20	13
Bank 5	04	Bank 21	14
Bank 6	05	Bank 22	15
Bank 7	06	Bank 23	16
Bank 8	07	Bank 24	17
Bank 9	08	Bank 25	18
Bank 10	09	Bank 26	19
Bank 11	0A	Bank 27	1A
Bank 12	0B	Bank 28	1B
Bank 13	4C	Bank 29	4C
Bank 14	0D	Bank 30	1D
Bank 15	0E	Bank 31	1E
Bank 16	0F	Bank 32	1F

## ● Reply

ACK	Number of words	Checksum
0x06	0	0xF9

## ■ Reading the recognized character string

Read the character string that has been recognized by the specified camera unit.

## ● Send

Barcode link ON

Command	Window	Fixed	Mode	Number of words	Additional reply	Checksum
0xE8 + head number	Inspection window number	0xF0	0x01	0	0	Command to checksum

Barcode link OFF

Command	Window	Fixed	Mode	Number of words	Additional reply	Checksum
0x28 + head number	Inspection window number	0xF0	0x01	0	0	Command to checksum

**Example of sending the command when the barcode link function is off**

Acquiring character string "2018.10.03 AB" read by inspection window 1 of the camera unit connected to head 1

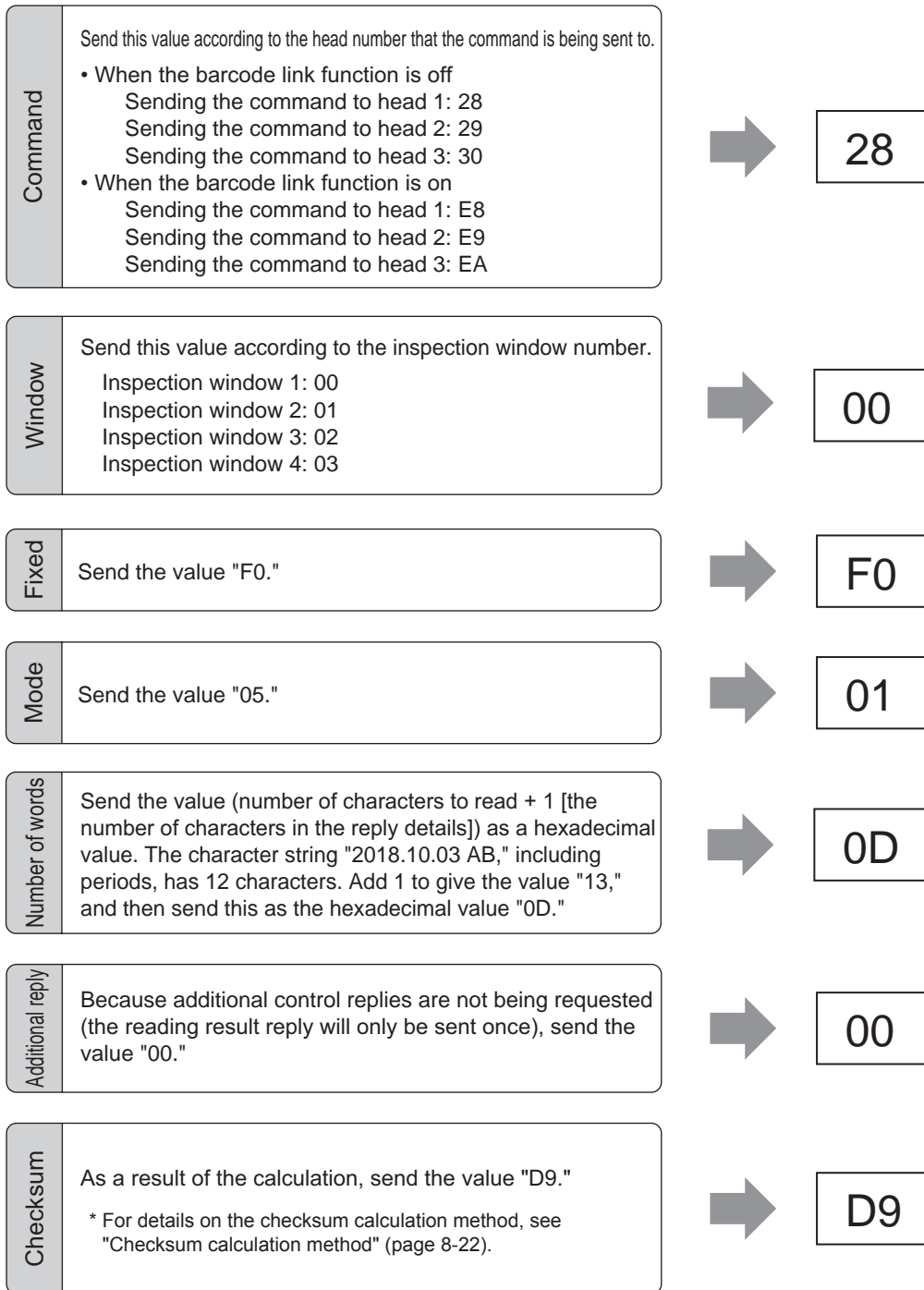



## ■ Reading the recognized character string and the match rate

Read the recognition result and match rate of the character string that has been recognized by the specified camera unit.

### ● Send

Barcode link ON

Command	Window	Fixed	Mode	Number of words	Additional reply	Checksum
0xE8 + head number	Inspection window number	0xF0	0x05	0	0	Command to checksum

Barcode link OFF

Command	Window	Fixed	Mode	Number of words	Additional reply	Checksum
0x28 + head number	Inspection window number	0xF0	0x05	0	0	Command to checksum

### Example of sending the command when barcode link function is off

Acquiring the recognition result and match rate of the character string "2018.10.03 AB" read by inspection window 1 of the camera unit connected to head 1

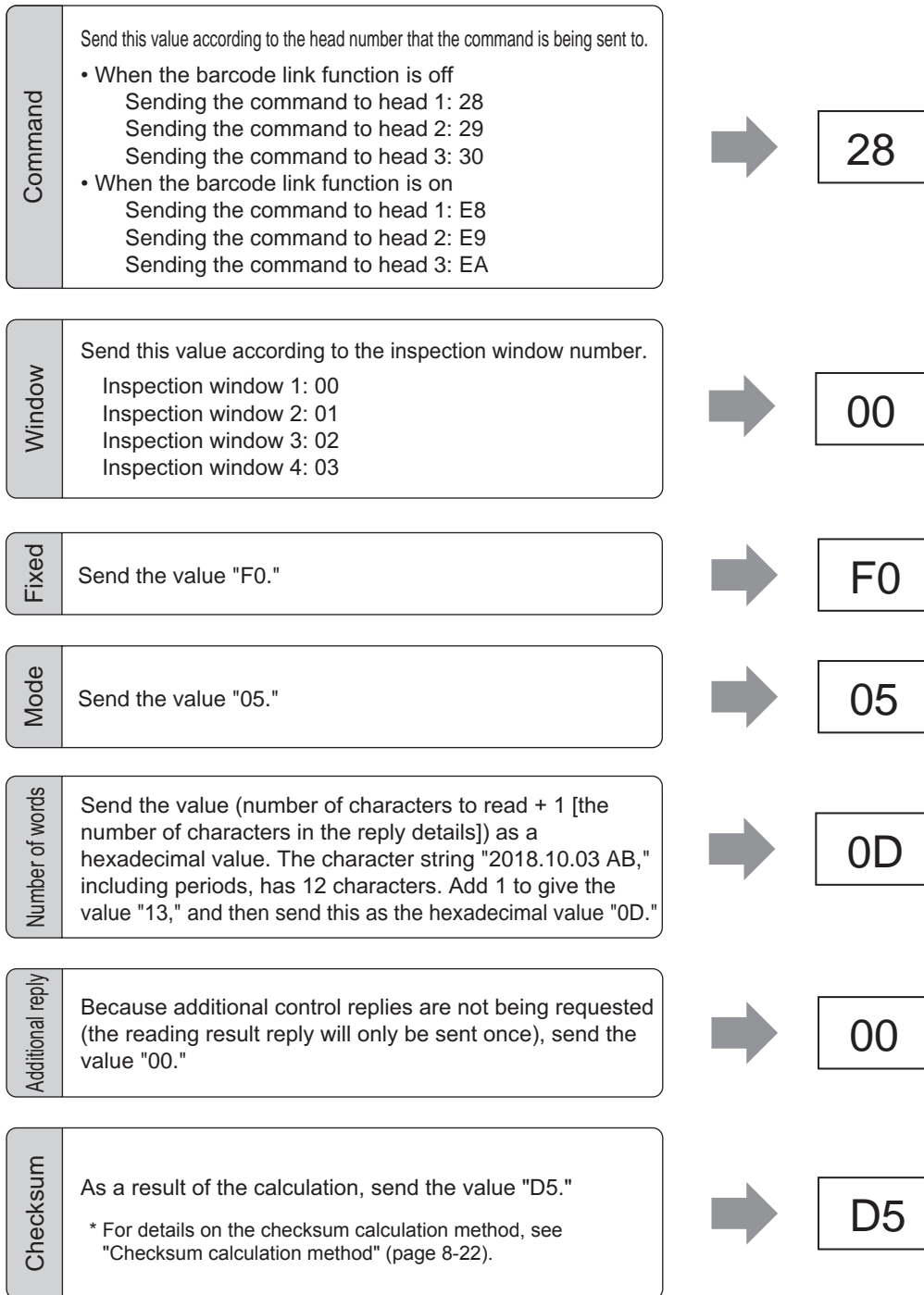

## ● Reply

ACK	Number of words	Number of characters	Disabled	Result	Character 1	Match rate	...	Checksum
0x06	0 to 250	0 to 64	0	1: Pass 2: Fail	Recognized character (ASCII)	Match rate 0 to 100	Repeated up to the number of characters	ACK to checksum

- The judgment result as well as the recognition result and match rate for each character are output.

### Reply example

Output of the reading result for character string "2018.10.03 AB"

ACK	Number of words	Number of characters	Result	[Character 1]	[Match rate]	[Character 2]	[Match rate]	[Character 3]	[Match rate]	[Character 4]	[Match rate]	[Character 5]	[Match rate]	[Character 6]	[Match rate]	
06	0D	0C	01	32	5F	30	5E	31	59	38	59	2E	5A	31	5F	
			OK	2	95	0	94	1	89	8	89	.	90	1	95	
[Character 7]	[Match rate]	[Character 8]	[Match rate]	[Character 9]	[Match rate]	[Character 10]	[Match rate]	[Character 11]	[Match rate]	[Character 12]	[Match rate]					
30	5B	2E	5A	30	5C	33	55	41	5C	42	63	24				
0	91	.	90	0	92	3	85	A	92	B	99	Checksum				

\*The above reading results are only examples. Your results may be different.

## ●●● MEMO ●●●

### About the output recognition results

When recognizing characters, this device generates two recognition results: the recognition result as a numeric and an alphabet character (example: recognition result "2" is output as "2" as a numeric value and is output as "Z" as an alphabet character). However, only the numeric value or alphabet character recognition result is output when you are reading the recognized character string and match rates.

The format settings are used to control which result is output.

When a date format such as "YYYYMD" or "YYM" has been set

- Only numeric values are output for the recognition result.

When a "date + character string" format such as "2018.10.13 AB" has been set

- The recognition result for the date part is output as numeric values.
- If nothing has been set on the [Edit String] screen, the recognition result that has the higher match rate is output for the character string part ("AB" in the above example). If a reference string has been set on the [Edit String] screen, the recognition result is output according to the set character type (numeric value or alphabet character).

When no format has been set

- The recognition result that has the higher match rate is output.

## ■ Writing the reference string to compare

Write the reference string for the specified camera unit.

## ● Send

Barcode link ON

Command	Window	Fixed	Mode	Number of words	Additional reply	Checksum
0xD4 + head number	Inspection window number	0x35	0x01	0 to 250	0	Command to checksum

Character 1	Character 2	...	Checksum
Recognized character (ASCII)	Recognized character (ASCII)	Repeated up to the number of characters	Start of data to checksum

### Example of sending the command when barcode link function is on

Write "2018.10.03 AB" as the reference string of inspection window 1 of the camera unit connected to head 1

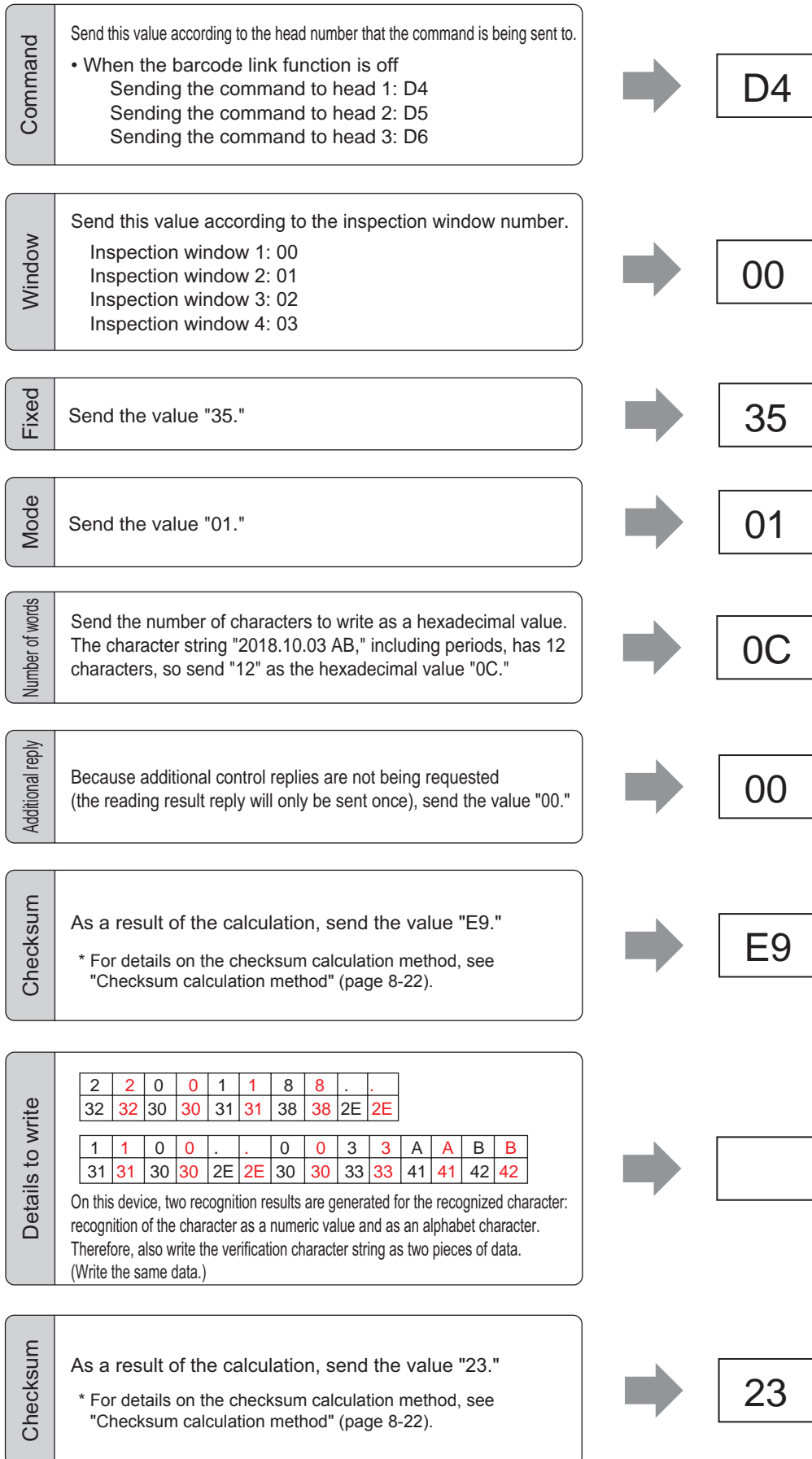

Barcode link OFF

Command	Window	Fixed	Mode	Number of words	Additional reply	Checksum
0x14 + head number	Inspection window number	0x35	0x01	0 to 250	0	Command to checksum

Character 1	Character 2	...	Checksum
Recognized character (ASCII)	Recognized character (ASCII)	Repeated up to the number of characters	Start of data to checksum

**Example of sending the command when barcode link function is off**

Write "2018.10.03 AB" as the reference string of inspection window 1 of the camera unit connected to head 1

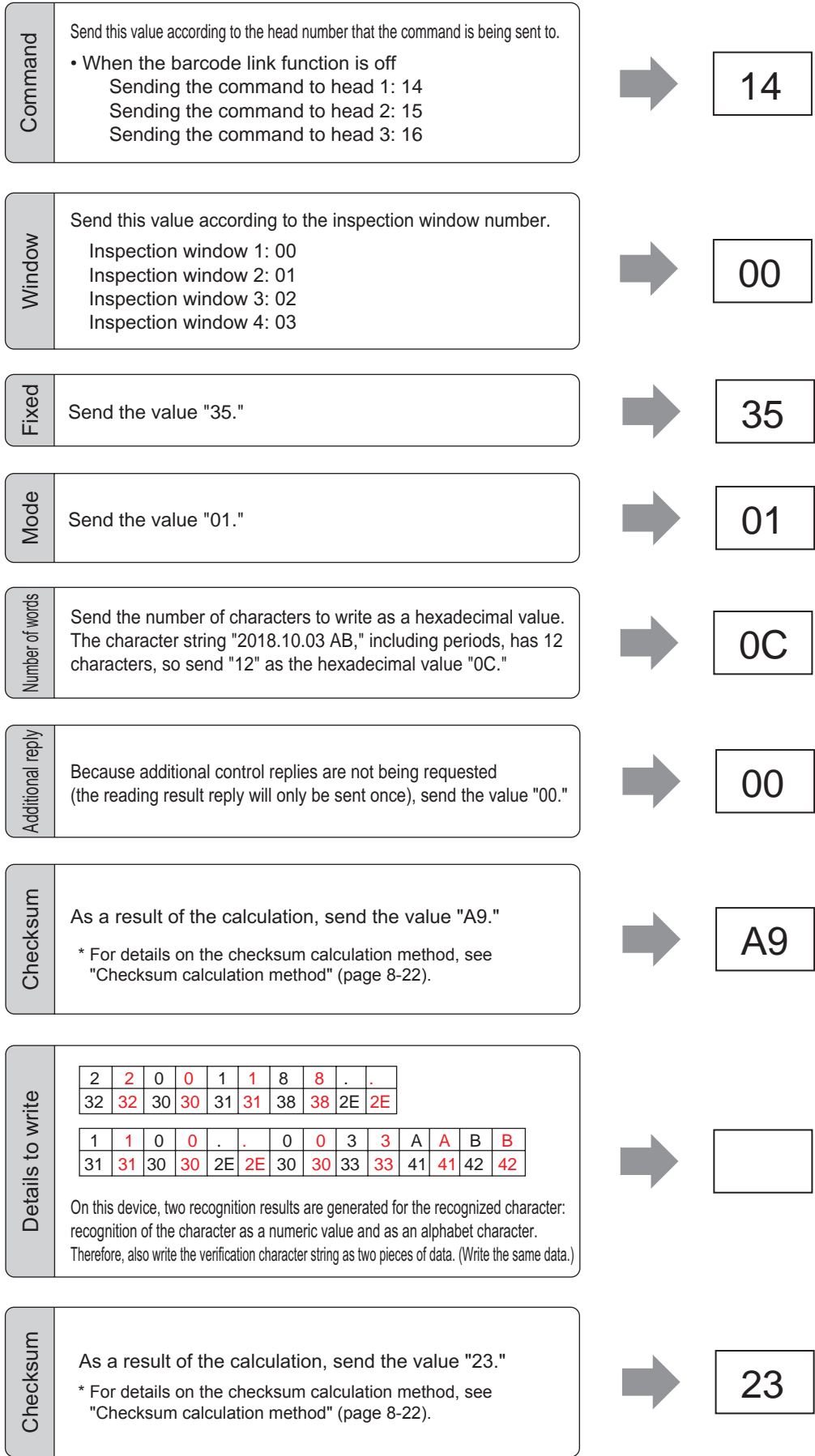

## ● Reply

ACK	Number of words	Checksum
0x06	0	0xF9

## ●●● MEMO ●●●

When you use communication to write a reference string, the character string is written to a different part of memory than that used by the main menu and the [Edit String] screen—which is accessed by touching [Settings] and then [Recog.]. Even if a different reference string has been set with the [Edit String] screen, the details that have been written using communication will be given priority.

You can only check the writing result with the operation screen and with the "Reading the reference string" command.

To delete the reference string set using communication:

- (1) Restart the device.
- (2) Touch [OK] on the [Edit String] screen.
- (3) Switch the bank.
- (4) Execute the bank copy operation (only when copying to the current bank).
- (5) Switch to the NG analysis screen.
- (6) Use an input or output test.
- (7) Execute the setup function.

If you perform one of the above operations, write the reference string again from the host side.

## ■ Reading the reference string

Read the reference string of the specified head and inspection window.

### ● Send

Barcode link ON

Command	Window	Fixed	Mode	Number of words	Additional reply	Checksum
0xD0 + head number	Inspection window number	0x00	0x01	0 to 250	0	Command to checksum

Barcode link OFF

Command	Window	Fixed	Mode	Number of words	Additional reply	Checksum
0x10 + head number	Inspection window number	0x00	0x01	0 to 250	0	Command to checksum

## Example of sending the command when barcode link function is off

Acquiring reference string "2018.10.03 AB" set to inspection window 1 of the camera unit connected to head 1

Command	<p>Send this value according to the head number that the command is being sent to.</p> <ul style="list-style-type: none"><li>• When the barcode link function is off<ul style="list-style-type: none"><li>Sending the command to head 1: 10</li><li>Sending the command to head 2: 11</li><li>Sending the command to head 3: 12</li></ul></li><li>• When the barcode link function is on<ul style="list-style-type: none"><li>Sending the command to head 1: D0</li><li>Sending the command to head 2: D1</li><li>Sending the command to head 3: D2</li></ul></li></ul>	→	10
Window	<p>Send this value according to the inspection window number.</p> <ul style="list-style-type: none"><li>Inspection window 1: 00</li><li>Inspection window 2: 01</li><li>Inspection window 3: 02</li><li>Inspection window 4: 03</li></ul>	→	00
Fixed	<p>Send the value "00."</p>	→	00
Mode	<p>Send the value "01."</p>	→	01
Number of words	<p>Send the value (number of characters to read + 1 [the number of characters in the reply details]) as a hexadecimal value. The character string "2018.10.03 AB," including periods, has 12 characters. Add 1 to give the value "13," and then send this as the hexadecimal value "0D."</p>	→	0D
Additional reply	<p>Because additional control replies are not being requested (the reading result reply will only be sent once), send the value "00."</p>	→	00
Checksum	<p>As a result of the calculation, send the value "E1."</p> <p>* For details on the checksum calculation method, see "Checksum calculation method" (page 8-22).</p>	→	E1

## ● Reply

ACK	Number of words	Number of characters	Disabled	Character 1	Character 1	...	Checksum
0x06	0 to 250	0 to 64	0	Recognized character (ASCII)	Recognized character (ASCII)	Repeated up to the number of characters	ACK to checksum

### Reply example

```

ACK      Number of words  Number of characters  Disabled  [Character 1]  [Character 2]  [Character 3]  [Character 4]  [Character 5]  [Character 6]
06 0D 0C 00 32 32 30 30 31 31 38 38 2E 2E 31 31
           2   2   0   0   1   1   8   8   .   .   1   1

[Character 7] [Character 8] [Character 9] [Character 10] [Character 11] [Character 12]
30 30 2E 2E 30 30 33 33 41 41 42 42 04
  0   0   .   .   0   0   3   3   A   A   B   B   Checksum
  
```

\* The above reading results are only examples. Your results may be different.

## ●●● MEMO ●●●

Details on the character string read when you use the "Reading the reference string" command are shown below.

- When you use the "Writing the reference string" command to write the reference string using communication, the details that are read are those that have been written using communication, not those that have been set on the [Edit String] screen.

(The character string that you have written using communication is written to a different part of memory than that used by the main menu and the [Edit String] screen—which is accessed by touching [Settings] and then [Recog.] )

- To read the reference string that has been set with the [Edit String] screen, touch [OK] on the [Edit String] screen or restart the device.

## ■ Switching to USB serial communication mode

Switch the communication port from RS-232C to the USB port in order to enable the execution of commands from the USB port (USB mode). Do the same when using Ethernet communication to execute commands from the LAN port.

### ●●● MEMO ●●●

- This command can be received through the USB port or LAN port.
- When you execute this command, the RS-232C terminal will stop receiving input.

#### ● Send

Command 1	Command 2
0x55	0x8C

#### ● Reply

Reply 1	Reply 2
0x8C	0x73

## ■ Canceling USB mode

Cancel USB mode and enable the execution of commands from the RS-232C terminal.

#### ● Send

Command	Address	Fixed 1	Fixed 2	Fixed 3	Fixed 4	Checksum
0xFE	0x8C	0x73	0x00	0x00	0x00	0x02

#### ● Reply

The issuing of the above command causes the communication port to switch to the RS-232C terminal, so the reply is not output.

USB/Ethernet communication procedure example

(1) Establish a connection between the PC and the device.

- For details on the Ethernet connection, see "8-2 Configuring Ethernet Communication Settings (Only for Controllers with Ethernet Support)."
- Regarding the USB connection, when you install monitoring software "Ocr2Capture," the USB driver will be installed at the same time.

(2) Issue the command (0x558C) for switching to RS-232C mode.

(3) Within 5 seconds, issue the command that you want to execute.

(4) Issue the command (0xFE8C) for switching to USB mode.

### ●●● MEMO ●●●

- "2195" is the port used during Ethernet communication.
- "Ocr2Capture" can be downloaded from the MVS-OCR2 product page on the Optex FA website (<http://www.optex-fa.com/>).
- For details on the system requirements, installation, and operation of "Ocr2Capture," see the "Ocr2Capture User's Manual."

## ■ Setting the calendar timer

Set the values of the controller's calendar timer.

### ● Send

Command	Address	Fixed 1	Data	Fixed 2	Fixed 3	Checksum
0xF0	0x02 to 0x08	0x55	0x00 to 0xFF	0x45	0x19	*

\* The values from the command to the checksum are added, and this result is then inverted.

### ● Reply

ACK	Number of words	Checksum
0x06	0x00	0xF9

## MEMO

The year, month, day, hour, minute, and second values are assigned to the following addresses. Convert the values of the data to send into BCD form.

- **0x02:** Address to which the second is assigned. The following values are sent for the data.

Second (decimal, BCD)	0	1	...	59
Hexadecimal	0x00	0x01	...	0x59

- **0x03:** Address to which the minute is assigned. The following values are sent for the data.

Minute	0	1	...	59
Hexadecimal form	0x00	0x01	...	0x59

- **0x04:** Address to which the hour is assigned. The following values are sent for the data.

Hour	0	1	...	23
Hexadecimal form	0x00	0x01	...	0x23

- **0x05:** Address to which the day is assigned. The following values are sent for the data.

Day	1	2	...	31
Hexadecimal form	0x01	0x02	...	0x31

- **0x07:** Address to which the month is assigned. The following values are sent for the data.

Month	1	2	...	12
Hexadecimal form	0x01	0x02	...	0x12

- **0x08:** Address to which the year (the last two digits in the western calendar) is assigned. The following values are sent for the data.

2-digit year	00 (2000)	...	04 (2004)	...	99 (2099)
Hexadecimal form	0x00	...	0x01	...	0x99

## ■ Reading the calendar timer

Read the calendar timer value.

### ● Send

Command	Fixed 1	Fixed 2	Fixed 3	Fixed 4	Fixed 5	Checksum
0xF1	0x00	0x00	0x00	0x00	0x00	0x0E

### ● Reply

ACK	Number of words	Second	Minute	Hour	Day	Month	Year	Error	Fixed	Checksum
0x06	0x04	0 to 59	0 to 59	0 to 23	1 to 31	1 to 12	0 to 99	*1	0x00	*2

\*1 When an error has occurred: 0x80, when no error has occurred: 0x00

\*2 The values from the command to the checksum are added, and this result is then inverted.

## ●●● MEMO ●●●

When the calendar timer is read, the year, month, day, hour, minute, and second are all returned as binary values.

## ■ Reading the number of inspections

Read the current number of inspections. The upper limit is 99,999,999 for the OK result count and for the NG result count.

### ● Send

When the barcode link function is on

Command	Fixed	Fixed	Mode	Number of words	Additional reply	Checksum
0xE8 + head number	0x00	0x00	0x0A	4	0	Command to checksum

When the barcode link function is off

Command	Fixed	Fixed	Mode	Number of words	Additional reply	Checksum
0x28 + head number	0x00	0x00	0x0A	4	0	Command to checksum

### ● Reply

ACK	Number of words	1-2	3-4	Checksum
0x06	4	OK result count	NG result count	ACK to checksum

The formats of the OK and NG result counts are shown below. (4 bytes, LSB)

Word number	Word higher order bytes	Word lower order bytes
1	bp15-8	bp7-0
2	bp31-24	bp23-16

## ■ Resetting the OK and NG result counts

Reset the current OK and NG result counts to 0. You can also reset the counts separately.

	OK/NG value
Reset only the OK result count	0x01
Reset both the OK and NG result counts	0x03

### ● Send

When the barcode link function is on

Command	Fixed	OK/NG	Mode	Number of words	Additional reply	Checksum
0xE8 + head number	0x00	0x01 (OK) 0x03 (both OK and NG)	0xB	0	0	Command to checksum

When the barcode link function is off

Command	Fixed	OK/NG	Mode	Number of words	Additional reply	Checksum
0x28 + head number	0x00	0x01 (OK) 0x03 (both OK and NG)	0xB	0	0	Command to checksum

### ● Reply

ACK	Number of words	Checksum
0x06	0	0xF9

## Reference

### Checksum calculation method

The checksum is calculated as follows.

- 1 Add all the target items.

Hexadecimal

$$14 + 00 + 35 + 01 + 0A(10) + 00 = 54$$

- 2 Convert the value to binary.

Binary

01010100

- 3 Invert the binary value (change 0s to 1s and 1s to 0s).

Binary

- 4 Convert the value to hexadecimal. (If the value has three or more digits, use the lower two digits.)

Hexadecimal

AB

You can use the "Programmer" view of "Calculator" in the Windows accessories (the "Scientific" view of "Calculator" on Windows Vista and Windows XP) to perform calculations in hexadecimal and to convert values between hexadecimal and binary.

- In Windows, on the Start menu, click "All Programs," "Accessories," and then click "Calculator." Then, switch to the "Programmer" view.

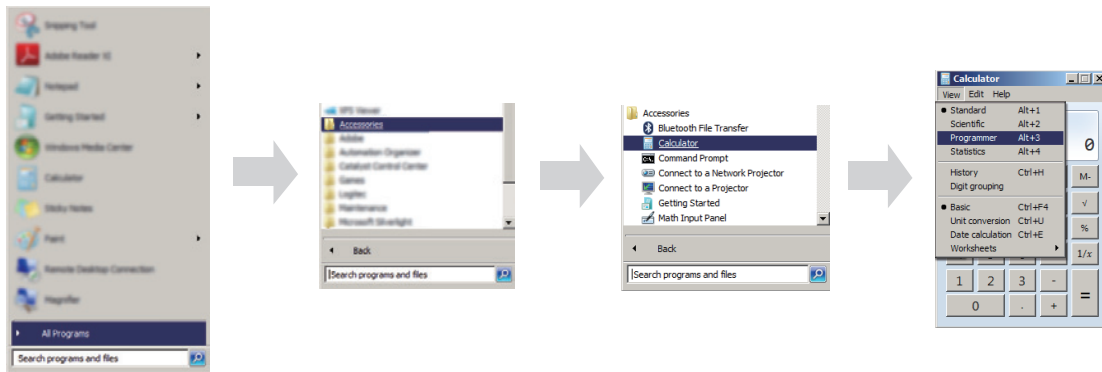

- Performing the above calculation method example in "Programmer" view

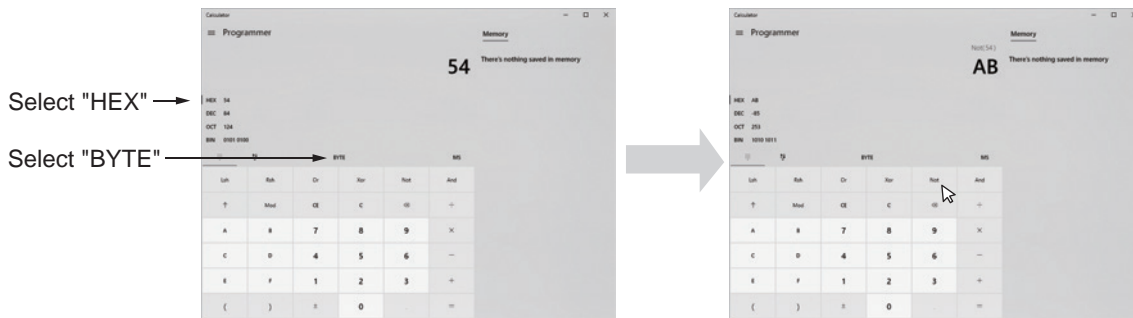

Perform the calculation in step 1.

Click "Not" to calculate the value to set the checksum to.

## Reference

### ASCII code table

Hexadecimal	Binary	0	1	2	3	4	5	6	7
		0	1	10	11	100	101	110	111
0	0	0	16	32	48	64	80	96	112
		<b>NUL</b>	<b>DLE</b>	<b>SP</b>	<b>0</b>	<b>@</b>	<b>P</b>	<b>`</b>	<b>p</b>
1	1	1	17	33	49	65	81	97	113
		<b>SOH</b>	<b>DC1</b>	<b>!</b>	<b>1</b>	<b>A</b>	<b>Q</b>	<b>a</b>	<b>q</b>
2	10	2	18	34	50	66	82	98	114
		<b>STX</b>	<b>DC2</b>	<b>"</b>	<b>2</b>	<b>B</b>	<b>R</b>	<b>b</b>	<b>r</b>
3	11	3	19	35	51	67	83	99	115
		<b>ETX</b>	<b>DC3</b>	<b>#</b>	<b>3</b>	<b>C</b>	<b>S</b>	<b>c</b>	<b>s</b>
4	100	4	20	36	52	68	84	100	116
		<b>EOT</b>	<b>DC4</b>	<b>\$</b>	<b>4</b>	<b>D</b>	<b>T</b>	<b>d</b>	<b>t</b>
5	101	5	21	37	53	69	85	101	117
		<b>ENQ</b>	<b>NAK</b>	<b>%</b>	<b>5</b>	<b>E</b>	<b>U</b>	<b>e</b>	<b>u</b>
6	110	6	22	38	54	70	86	102	118
		<b>ACK</b>	<b>SYN</b>	<b>&amp;</b>	<b>6</b>	<b>F</b>	<b>V</b>	<b>f</b>	<b>v</b>
7	111	7	23	39	55	71	87	103	119
		<b>BEL</b>	<b>ETB</b>	<b>'</b>	<b>7</b>	<b>G</b>	<b>W</b>	<b>g</b>	<b>w</b>
8	1000	8	24	40	56	72	88	104	120
		<b>BS</b>	<b>CAN</b>	<b>(</b>	<b>8</b>	<b>H</b>	<b>X</b>	<b>h</b>	<b>x</b>
9	1001	9	25	41	57	73	89	105	130
		<b>HT</b>	<b>EM</b>	<b>)</b>	<b>9</b>	<b>I</b>	<b>Y</b>	<b>i</b>	<b>y</b>
A	1010	10	26	42	58	74	90	106	131
		<b>LF</b>	<b>SUB</b>	<b>*</b>	<b>:</b>	<b>J</b>	<b>Z</b>	<b>j</b>	<b>z</b>
B	1011	11	27	43	59	75	91	107	123
		<b>VT</b>	<b>ESC</b>	<b>+</b>	<b>;</b>	<b>K</b>	<b>[</b>	<b>k</b>	<b>↓*</b>
C	1100	12	28	44	60	76	92	108	124
		<b>FF</b>	<b>FS</b>	<b>.</b>	<b>&lt;</b>	<b>L</b>	<b>\</b>	<b>l</b>	<b> </b>
D	1101	13	29	45	61	77	93	109	125
		<b>CR</b>	<b>GS</b>	<b>-</b>	<b>=</b>	<b>M</b>	<b>]</b>	<b>m</b>	<b>}</b>
E	1110	14	30	46	62	78	94	110	126
		<b>SO</b>	<b>RS</b>	<b>•</b>	<b>&gt;</b>	<b>N</b>	<b>^</b>	<b>n</b>	<b>~</b>
F	1111	15	31	47	63	79	95	111	127
		<b>SI</b>	<b>US</b>	<b>/</b>	<b>?</b>	<b>O</b>	<b>_</b>	<b>o</b>	<b>DEL</b>

\*1 This code indicates the line feed position. This is not a normal ASCII code. It is a proprietary code that is used by this device.

\*2 In ASCII code, the yen character is displayed as a backslash (\).

## 8-2 Configuring Ethernet Communication Settings (Only for Controllers with Ethernet Support)

Controllers with Ethernet support (MVS-DN-E/MVS-DP-E) can communicate using Ethernet.

You can perform a variety of operations from your computer such as capturing inspection screens and reading, writing, and editing settings and the extended dictionary. Run "Ocr2Capture" on the setup computer and establish an Ethernet connection to the controller.

### MEMO

- Contact your network administrator before you connect the device to a corporate or factory network.
- To connect the device to a programmable logic controller (PLC), check the manual of the programmable logic controller.
- "Ocr2Capture" can be downloaded from the MVS-OCR2 product page on the Optex FA website (<http://www.optex-fa.com/>).
- For details on the system requirements, installation, and operation of "Ocr2Capture," see the "Ocr2Capture User's Manual."

### 8-2-1 Preparation

- 1 Use a LAN cable to connect the LAN ports of the controller and the setup computer.

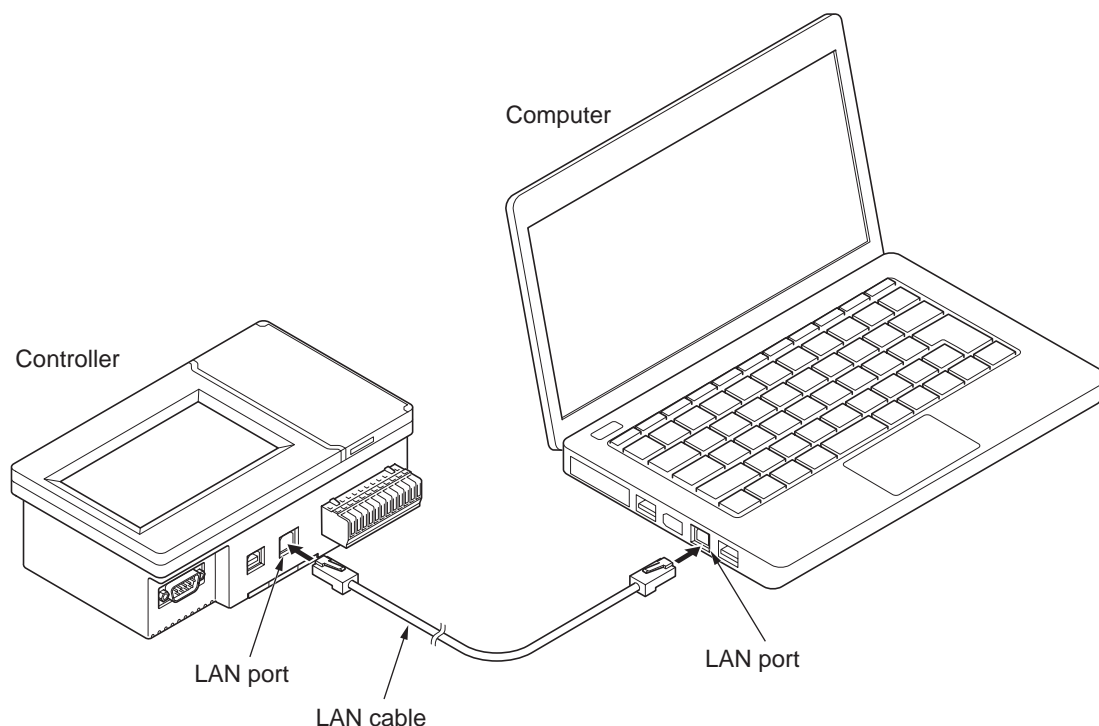

- 2 Turn on the controller while pressing the  key.
- 3 Record the "IP address," "Net mask," and "Gateway" that are displayed on the controller screen.

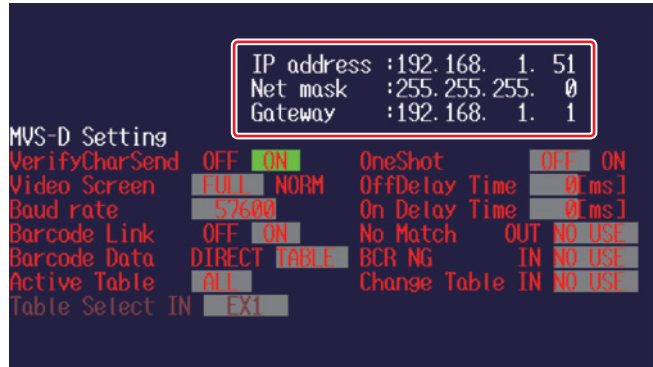

- 4 Install "Ocr2Capture" on the setup computer.  
When the installation is finished, a folder named [OPTEx FA] will be created in the [Start] menu in Windows.

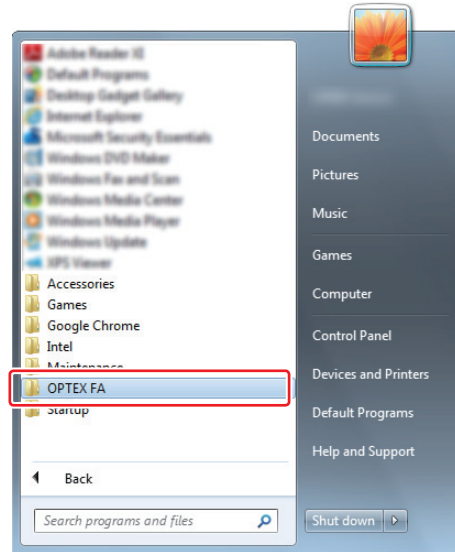

## 8-2-2 Set Communications on the Computer

Configure the communication settings on the setup computer.

### Windows 7

- 1 Click the [Start] button, and then click [Control Panel].  
The "Control Panel" screen displays.

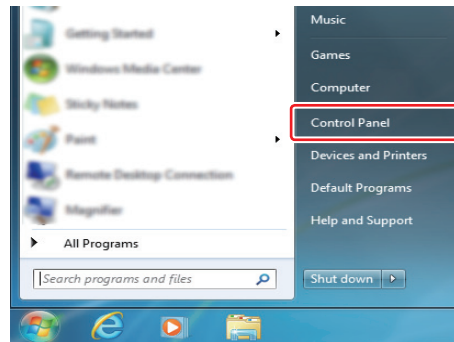

- 2 Under [Network and Internet], click [View network status and tasks].  
The "Network and Sharing Center" screen displays.

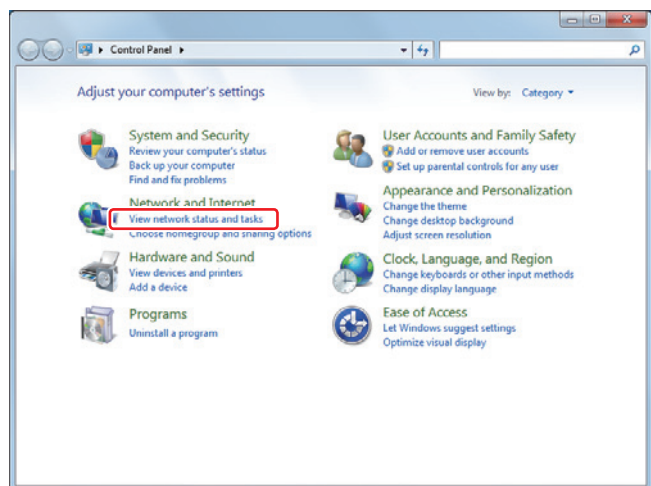

- 3 On the menu on the left, click [Change adapter settings].  
The "Network Connections" screen displays.

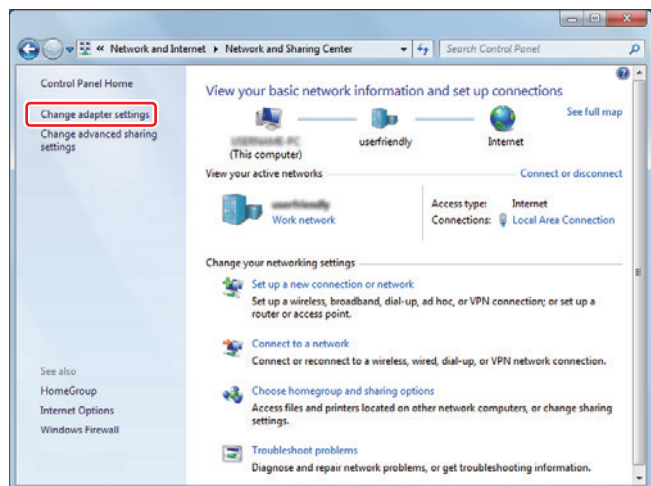

- 4** Double-click the [Local Area Connection] icon.  
The "Local Area Connection Status" dialog box displays.

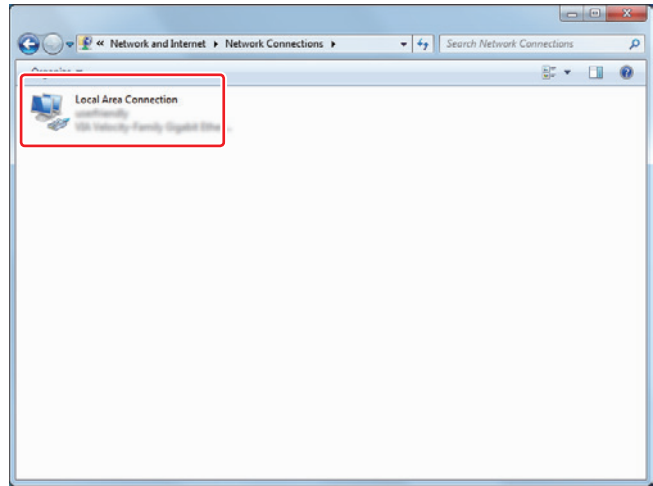

- 5** Click [Properties].  
The "Local Area Connection Properties" dialog box displays.

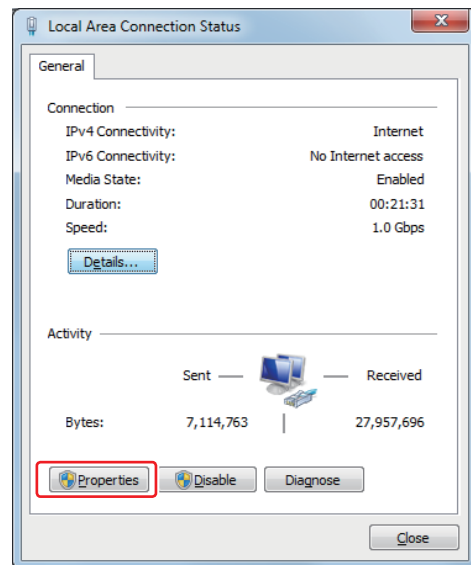

- 6** Click [Internet Protocol Version 4 (TCP/IPv4)], and then click [Properties].  
The "Internet Protocol Version 4 (TCP/IPv4) Properties" dialog box displays.

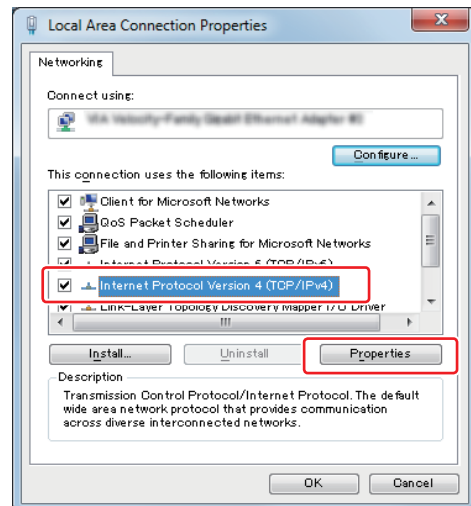

**7** Click [Use the following IP address:].

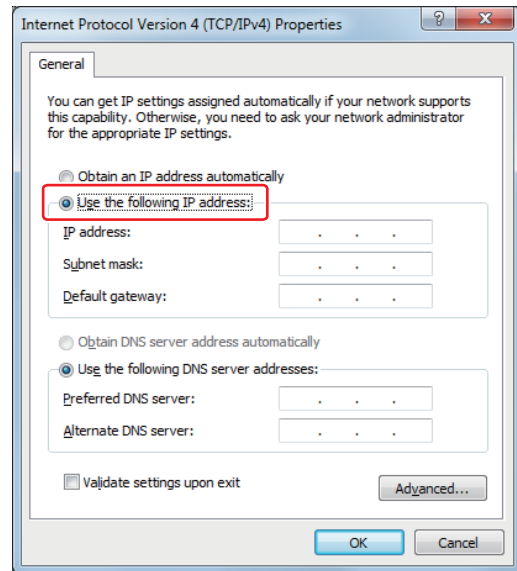

**8** Enter the computer's IP address in [IP address:].

Configure this setting so that the network numbers (framed in blue) are the same as and the host number (framed in red) is different from the IP address of the controller that you recorded in step 3 of the procedure in "8-2-1 Preparation" (page 8-24). For example, if the host number of the controller's IP address is "51," set the host number of the computer's IP address to "50."

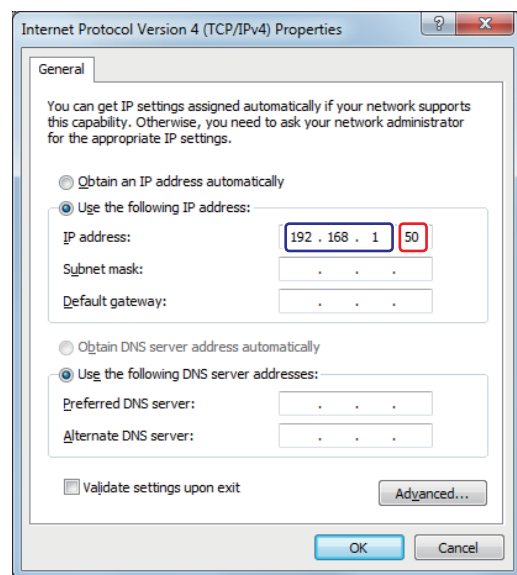

**9** Enter the same values for [Subnet mask:] and [Default gateway:] as the settings on the controller, and then click [OK].

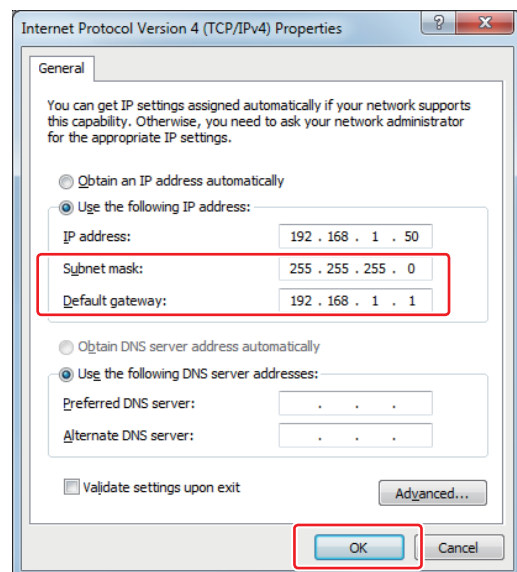

**10** Click [OK].

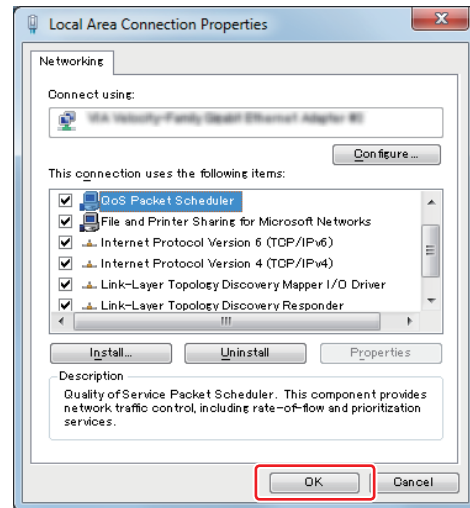

## Windows Vista

- 1** Click the [Start] button, and then click [Control Panel].  
The "Control Panel" screen displays.

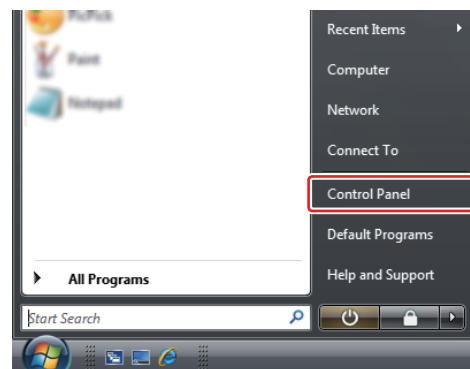

- 2** Under [Network and Internet], click [View network status and tasks].  
The "Network and Sharing Center" screen displays.

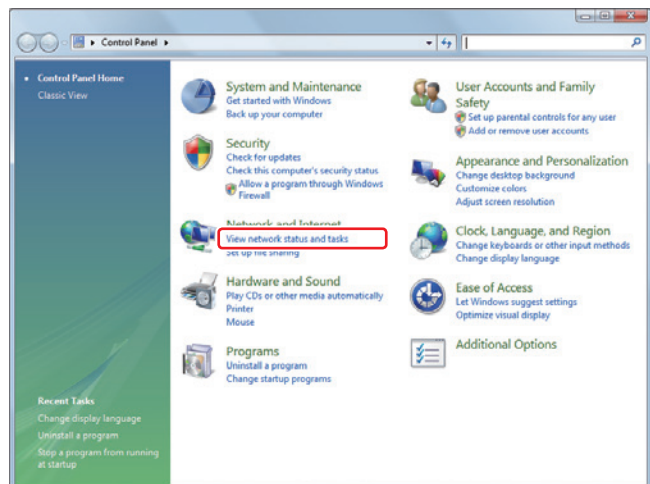

**3** On the menu on the left, click **[Manage network connections]**. The "Network Connections" screen displays.

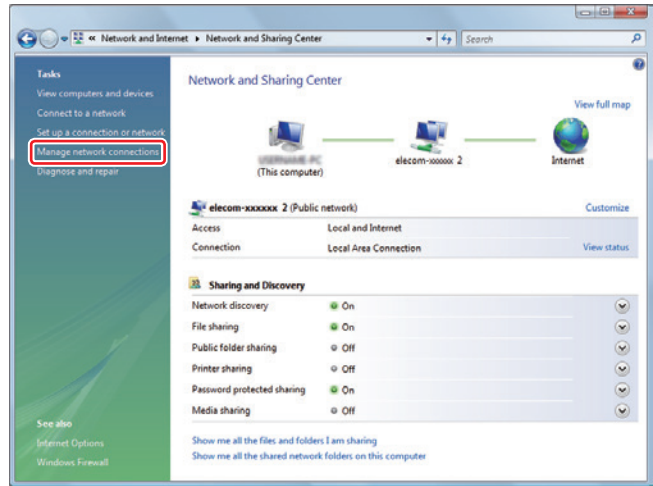

**4** Double-click the **[Local Area Connection]** icon. The "Local Area Connection Status" dialog box displays.

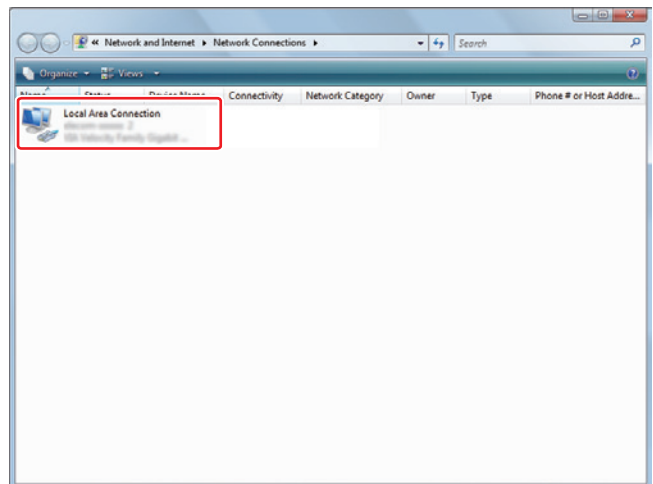

**5** Click **[Properties]**. The "Local Area Connection Properties" dialog box displays.

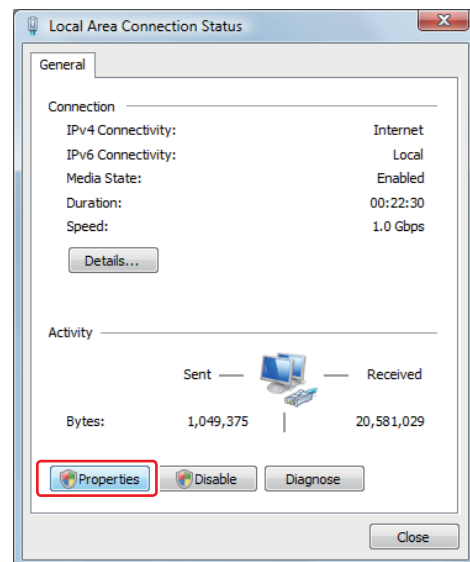

**6** Click [Internet Protocol Version 4 (TCP/IPv4)], and then click [Properties].

The "Internet Protocol Version 4 (TCP/IPv4) Properties" dialog box displays.

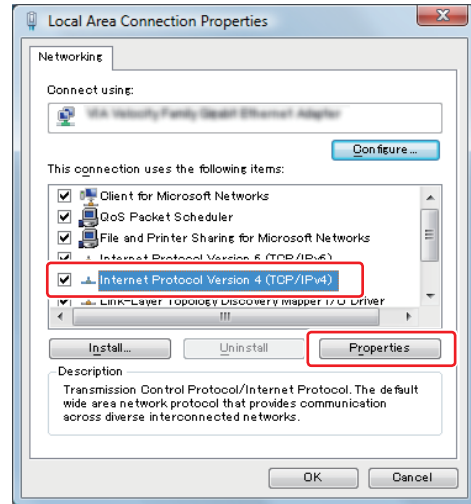

**7** Click [Use the following IP address:].

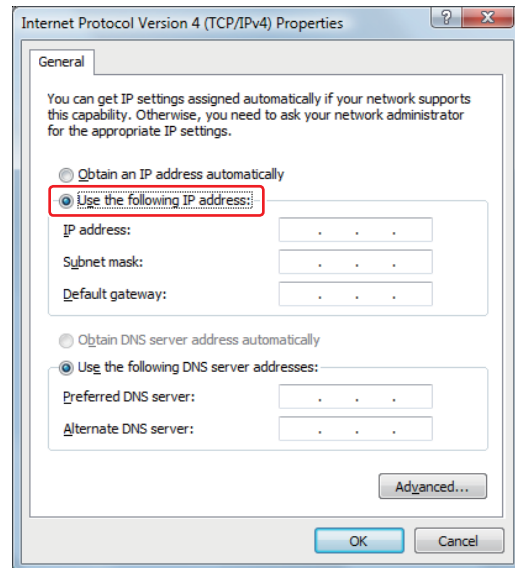

**8** Enter the computer's IP address for [IP address:].

Configure this setting so that the network numbers (framed in blue) are the same as and the host number (framed in red) is different from the IP address of the controller that you recorded in step 3 of the procedure in "8-2-1 Preparation" (page 8-24). For example, if the host number of the controller's IP address is "51," set the host number of the computer's IP address to "50."

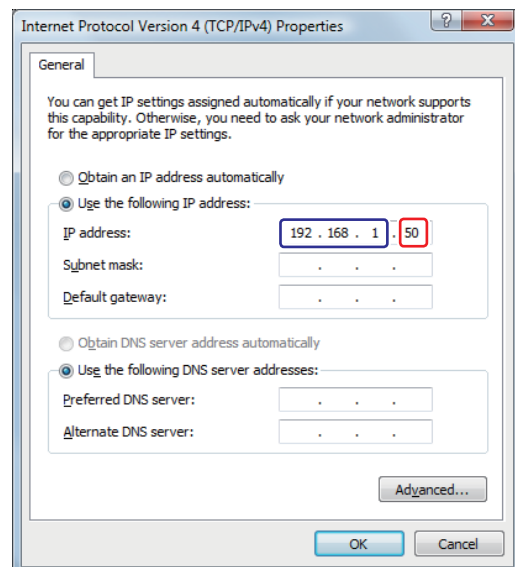

**9** Enter the same values for [Subnet mask:] and [Default gateway:] as the settings on the controller, and then click [OK].

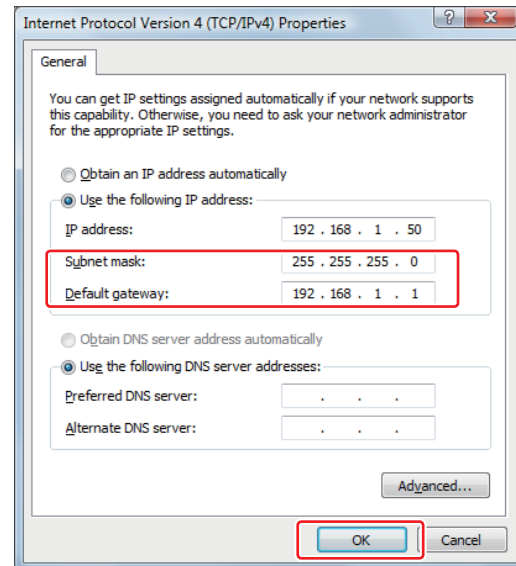

**10** Click [OK].

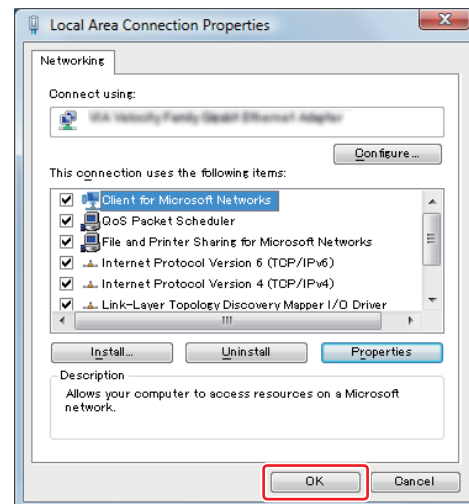

## ■ Windows XP

- 1 Click the [Start] button, and then click [Control Panel].  
The "Control Panel" screen displays.

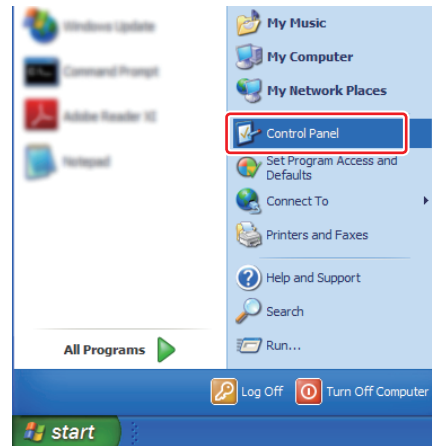

- 2 Double-click the [Network Connections] icon.  
The "Network Connections" screen displays.

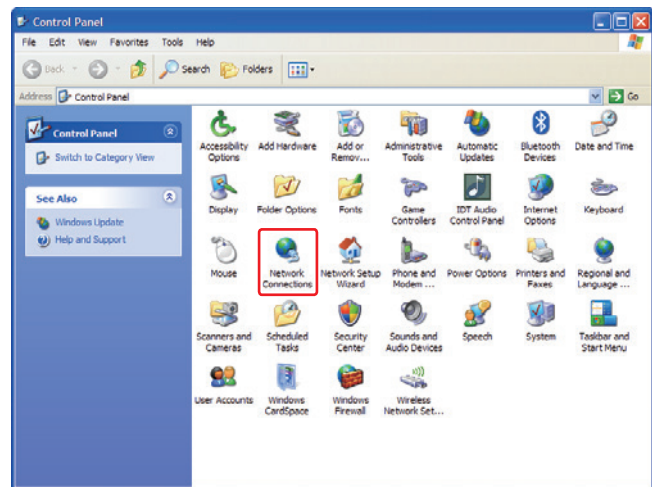

- 3 Double-click the [Local Area Connection] icon.  
The "Local Area Connection Status" dialog box displays.

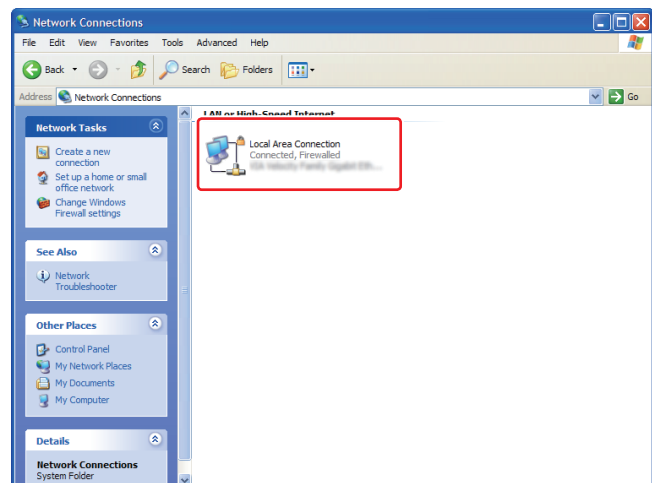

- 4** Click **[Properties]**.  
The "Local Area Connection Properties" dialog box displays.

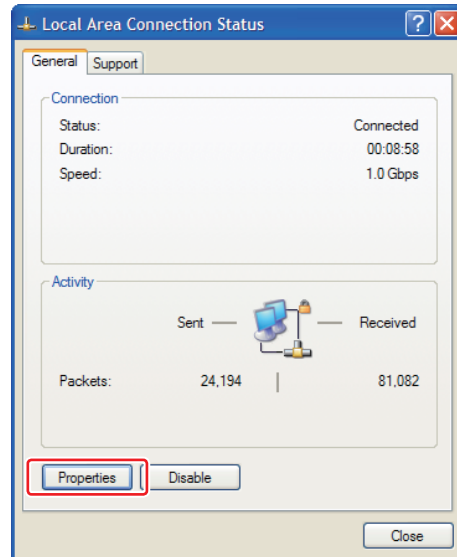

- 5** Click **[Internet Protocol (TCP/IP)]**, and then click **[Properties]**.  
The "Internet Protocol (TCP/IP) Properties" dialog box displays.

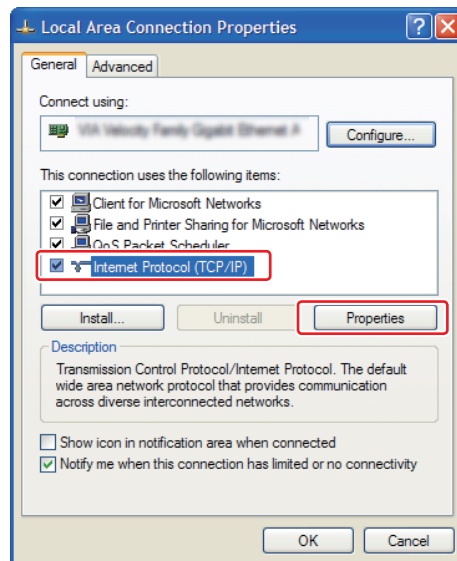

- 6** Click **[Use the following IP address:]**.

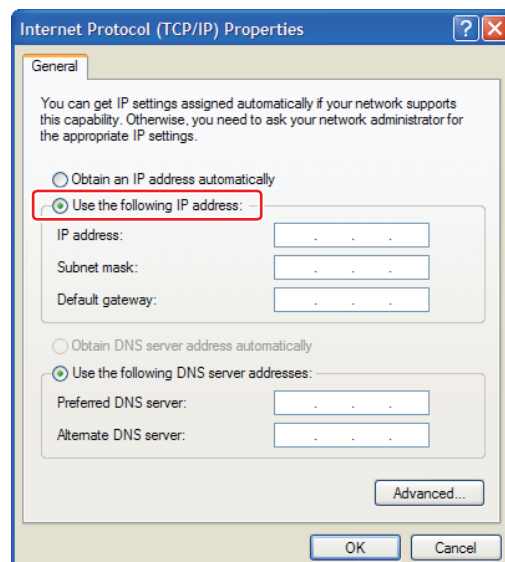

## 7 Enter the computer's IP address for [IP address:].

Configure this setting so that the network numbers (framed in blue) are the same as and the host number (framed in red) is different from the IP address of the controller that you recorded in step 3 of the procedure in "8-2-1 Preparation" (page 8-24). For example, if the host number of the controller's IP address is "51," set the host number of the computer's IP address to "50."

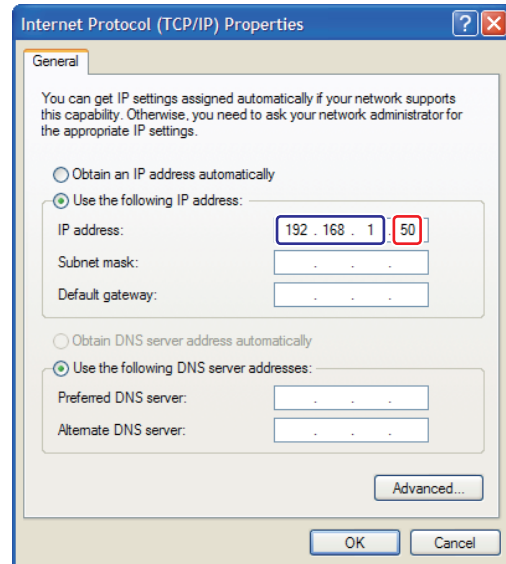

## 8 Enter the same values for [Subnet mask:] and [Default gateway:] as the settings on the controller, and then click [OK].

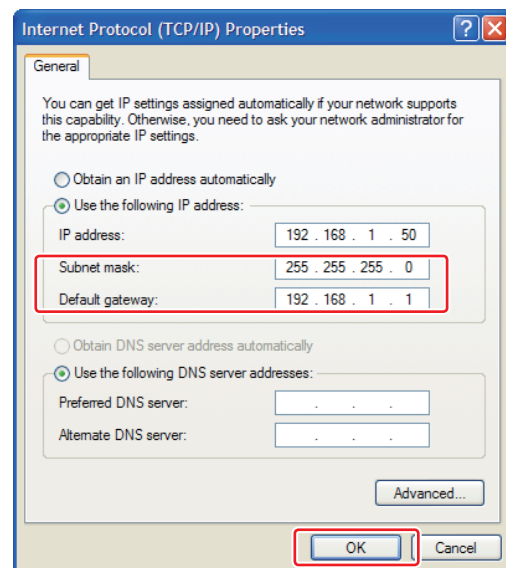

## 9 Click [OK].

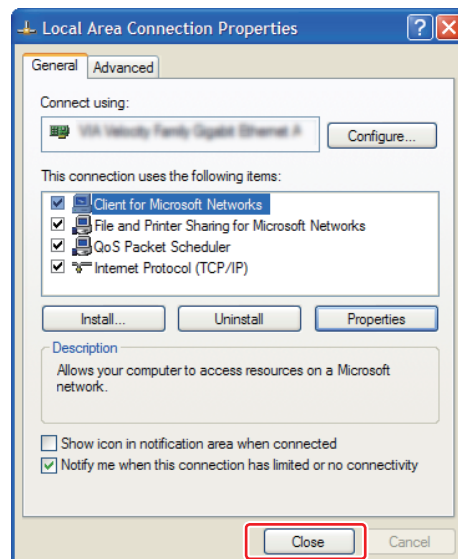

## 8-2-3 Configure Ocr2Capture Settings

Configure the settings of "Ocr2Capture," which you installed on the computer.

- 1 In Windows, on the [Start] menu, click [OPTEX FA], [Ocr2Capture], and then click [Ocr2Capture].

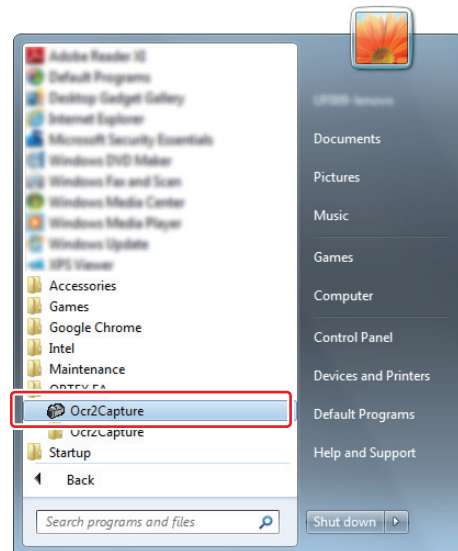

"Ocr2Capture" starts.

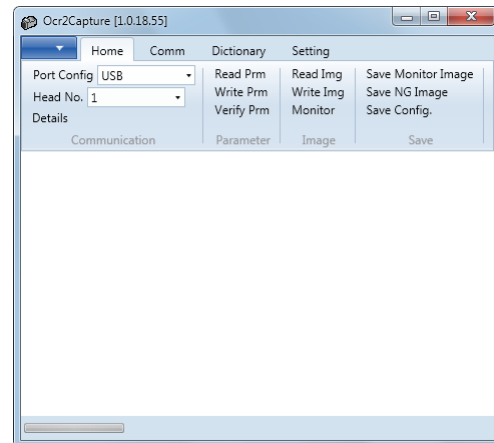

- 2 In the [Port Config] list, click [LAN].

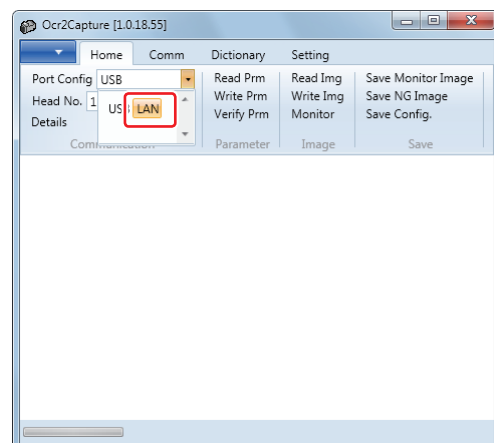

### MEMO

The items displayed in the list may vary depending on factors such as the connection environment and settings of the computer that you are using.

- 3** Click **[Details]**.  
The "Details" dialog box displays.

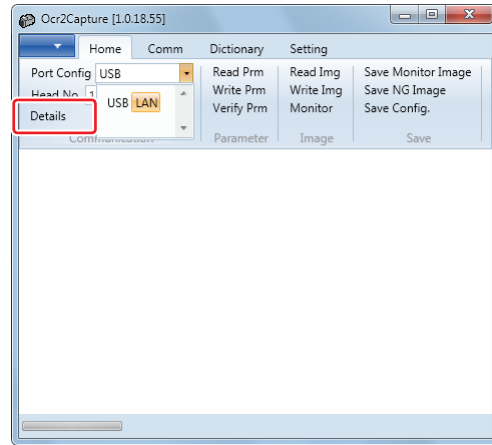

- 4** Click **[LAN]**.  
The LAN settings display.

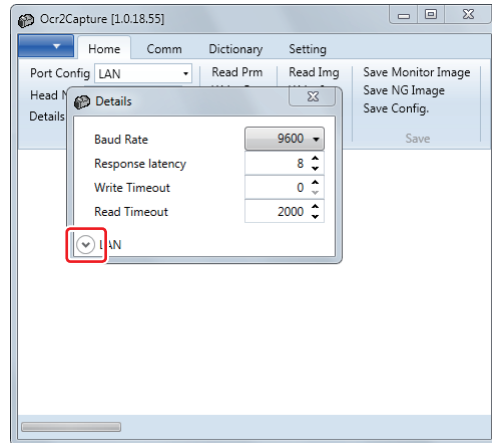

- 5** If necessary, set **[Name]** to a different name.

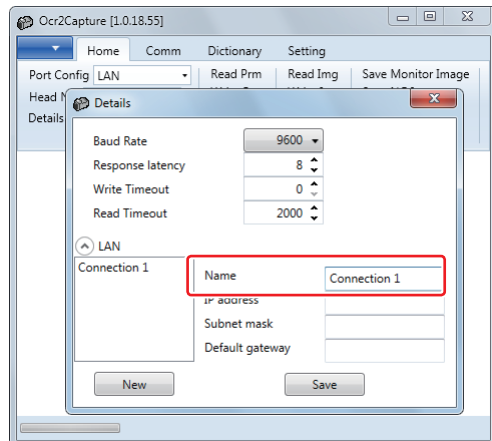

- 6** Set **[IP address]**, **[Subnet mask]**, and **[Default gateway]**.

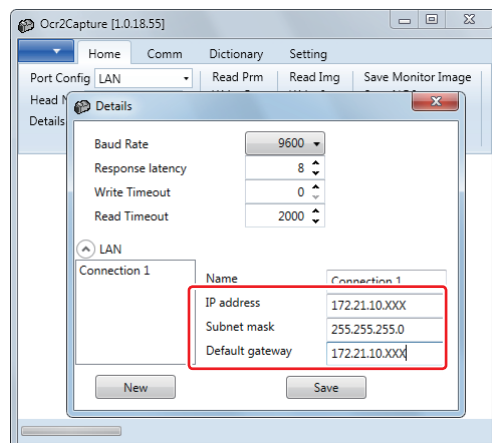

## MEMO

Contact your network administrator for the IP address that you can set here.

- 7 **Click [Save].**  
A message asking you to confirm that you want to apply the LAN settings displays.

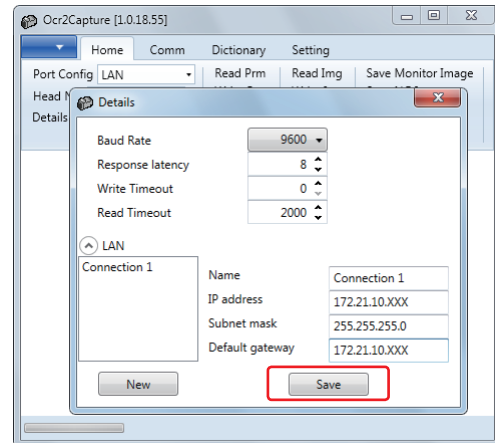

- 8 **Click [OK].**  
The LAN settings are applied to the controller.

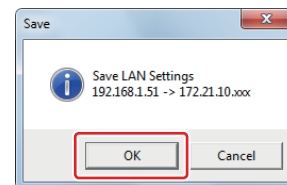

- 9 **Click [OK].**

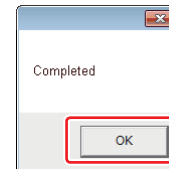

- 10 **Check that the "IP address," "Net mask," and "Gateway" values that you set with "Ocr2Capture" are displayed on the controller screen.**

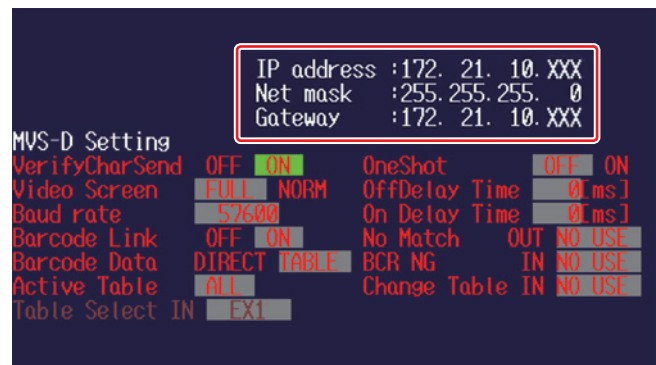

- 11 **Return the communication settings on the setup computer to their previous values.**

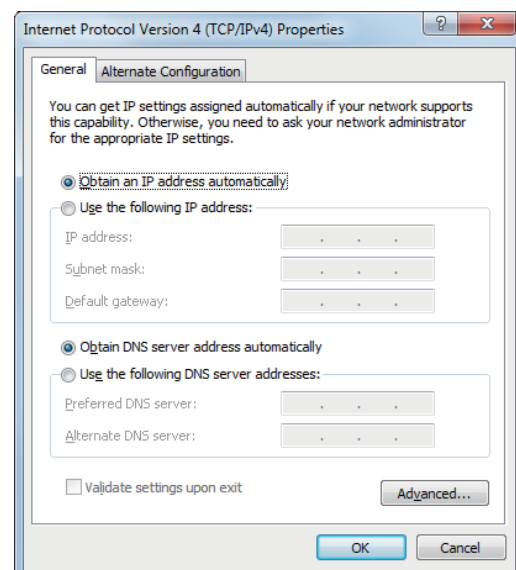

## MEMO

If you forget the original settings, contact your network administrator.

- 12 Disconnect the controller from the computer, and then connect the controller to the Ethernet network.

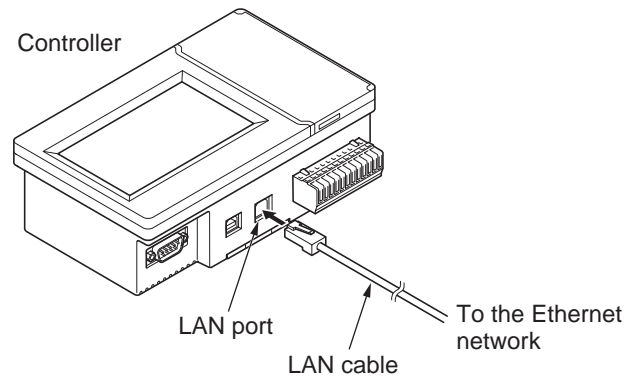

- 13 Click [Monitor].

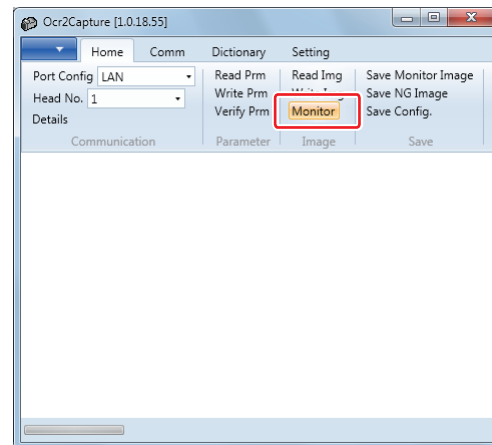

- 14 Check that the screen of the controller displays.

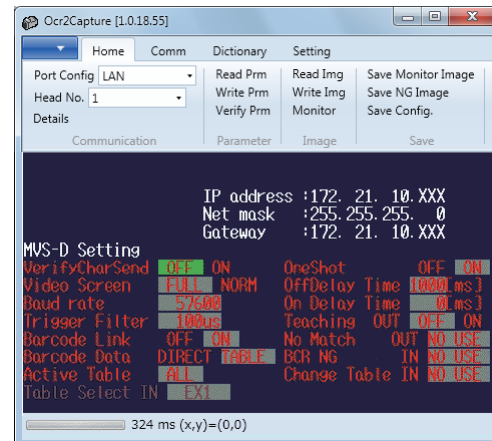

# 8-3 I/O Specifications

This section explains the specifications of the external I/O installed on the device.

## 8-3-1 Trigger Mode

The signals used to indicate the timing for capturing images are applied to trigger mode terminals T11 to T13.

Trigger Port	Details
T11	The T11 terminal will be used.
T12	The T12 terminal will be used.
T13	The T13 terminal will be used.
OrdrHead	The terminal that matches the head number will be used. Head 1: T11 Head 2: T12 Head 3: T13

Select the timing for capturing images from the options shown below.

Trigger Mode	Details
High	While the trigger mode terminal is set to ON, the device will repeat the following: capture the image, perform the inspection, and then perform the judgment.
Rise	Images will be captured when the trigger mode terminal switches from OFF to ON.
Low	While the trigger mode terminal is set to OFF, the device will repeat the following: capture the image, perform the inspection, and then perform the judgment.
Fall	Images are captured when the trigger mode terminal switches from ON to OFF.
Off	Images are captured automatically. The trigger mode terminal setting is ignored.

### MEMO

Trigger mode signals cannot be received from the start of image capture until image processing is finished.

To determine whether trigger mode signals can be received, check the status of the busy output terminal. Apply trigger mode signals when the busy signal is OFF.

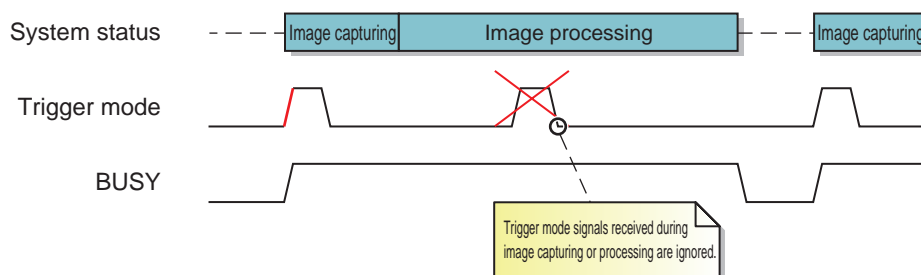

The timing of the input mode, busy, and light control signals is shown below.

Trigger mode timing

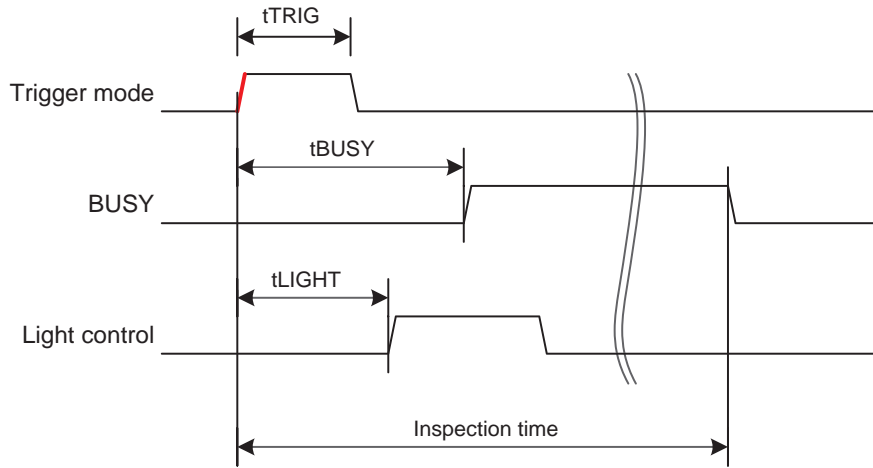

Symbol	Explanation	Time
tTRIG	The minimum pulse time when the trigger mode signal is ON.	15 $\mu$ s minimum
tBUSY	The time from when the trigger mode signal is ON to when the busy signal is ON.	888 $\mu$ s maximum
tLIGHT	The time from when the trigger mode signal is ON to when the light control signal is ON. * The tLIGHT value does not include the trigger delay time (see the next section).	80 $\mu$ s maximum

## 8-3-2 Trigger Delay

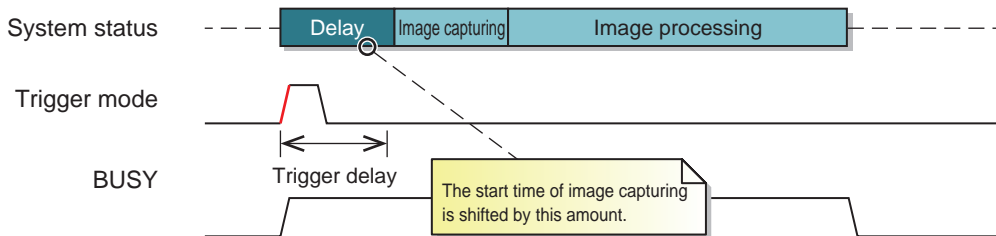

When you cannot capture images due to an offset between the trigger mode timing signals and the camera's installation position, you can set the trigger delay time to delay by the length of time the camera requires for image capture.

Trigger Delay	Details
0.0 to 6000.0	Specify a value from 0 to 6000 ms in units of 0.1 ms (100 $\mu$ s).

## 8-3-3 Sync Pulse Port

Use an encoder to correct position offsets caused by changes in the workpiece movement speed, and thereby capture images with accurate trigger positions. After the trigger mode is received, image capturing starts when the number of pulses set with [Sync Pulse Count] are sent by the encoder and received by the specified trigger terminal.

When [Sync Pulse Port] is set to a terminal (that is, it is not set to "Off"), the [Trigger Delay] setting is disabled.

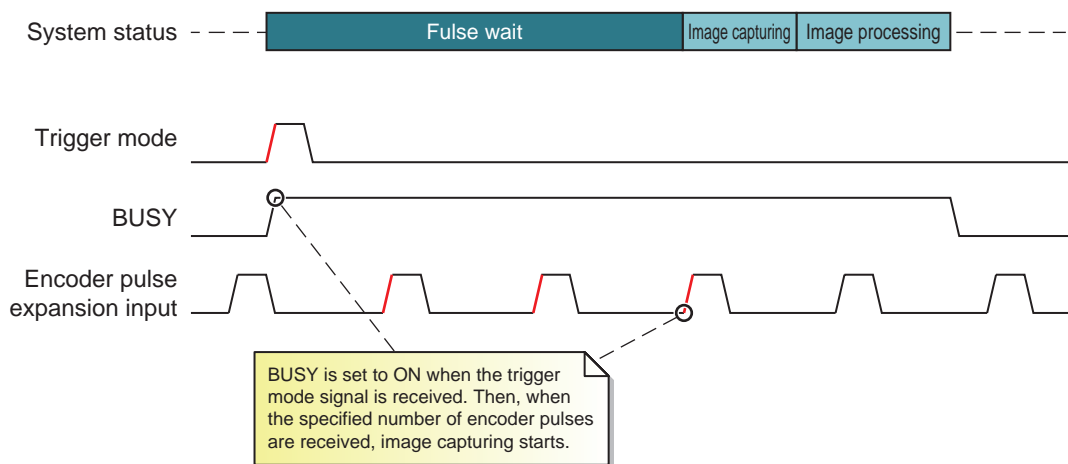

Minimum encoder pulse width (ON time) = 120  $\mu$ s

Minimum encoder pulse period = 250  $\mu$ s (4 kHz)

Sync Pulse Port	Explanation
Off	This function will not be used.
EX1 to EX10 T11 to T13	Images will be captured when the corresponding terminal turns ON the number of times set with [Sync Pulse Count]. If [Trigger Mode] is set to "Off," this function has no effect.

Sync Pulse Count	Explanation
1 to 65535	Specify the number of encoder pulses to receive. When the specified number of pulses are received, image capturing will start.

## 8-3-4 Force Trigger

Images will be captured while the set input is set to ON.

Use this function when the trigger mode terminals (T11 to T13) are connected to devices and you want to use another terminal to capture images.

In this case, images will be captured with [Trigger Mode] set to "High" and [Trigger Delay] set to "0."

If [Trigger Mode] is set to "Off," this function will be disabled.

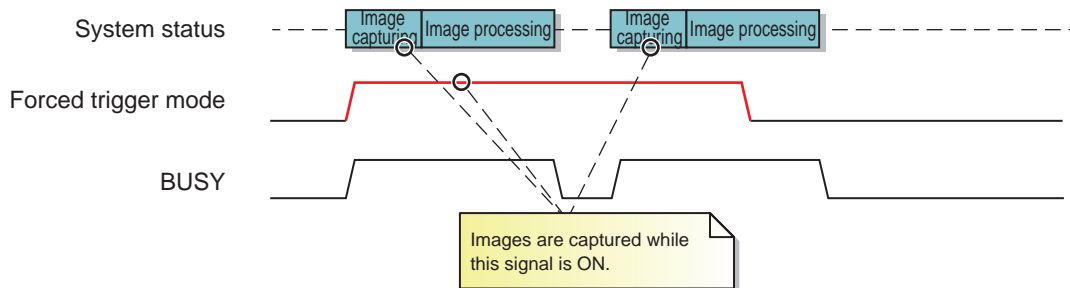

Force Trigger	Details
Off	This function will not be used.
EX1 to EX10 T11 to T13	When the corresponding terminal is set to ON, images will be force captured.

## 8-3-5 Trigger Check Output

If the time that the trigger mode signal is ON or OFF exceeds the time set with [TrgChk Time], the expansion output terminal is set to ON.

Use this function when the detection sensor remains ON due to workpieces being close to each other as they pass along the production line.

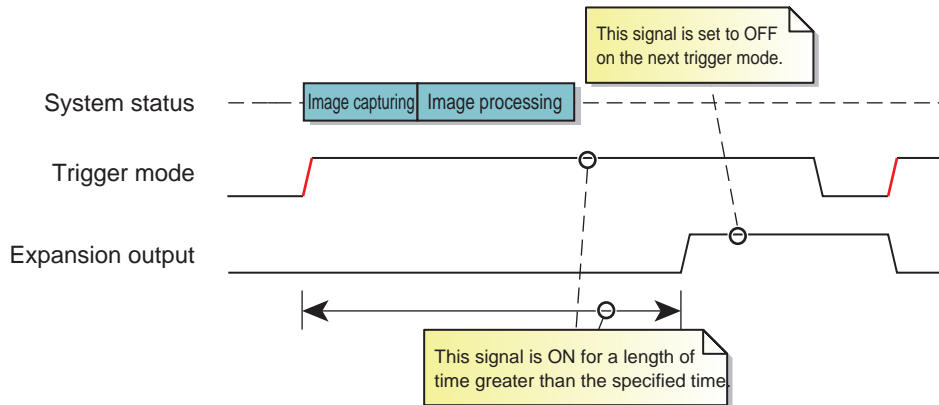

You can select "level output" or "one-shot output" for the output method.

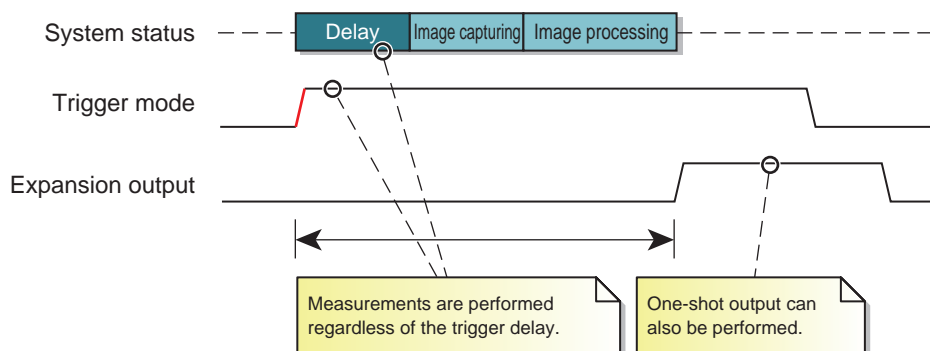

The BUSY double trigger is only detected on the rising edge or falling edge of the trigger mode signal.

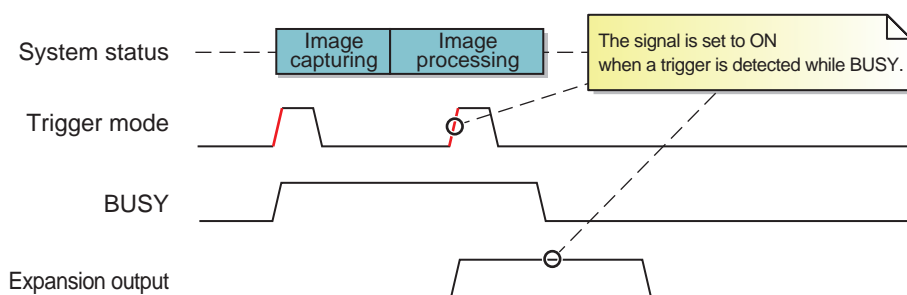

Trigger Check	Details
Off	This function will not be used.
On	When [Trigger Mode] is set to "Rose," the ON time will be measured. When [Trigger Mode] is set to "Fell," the OFF time will be measured.

TrgChk Time	Details
0 to 6000	Set the upper limit of the trigger mode ON time in units of 1 ms.

TrgChk Port	Details
EY1 to EY20	Select the output signal to use in sending notifications of error occurrences.

TrgChk One-Shot	Details
Off	Error notifications are output using level output. Error notifications are turned off the next time an image is captured.
On	Error notifications are output using one-shot output.

TrgChk On-Dly	Details
0 to 5000	Set the time, in units of 1 ms, until the error notification is set to ON.

TrgChk Off-Dly	Details
0 to 5000	Set the time, in units of 1 ms, until the error notification changes from ON to OFF.

TriggerFilter	Details
0 to 50	Set the filter time of the trigger input in units of 1 ms.

## 8-3-6 Bank Switching Input

If you set [Bank Select] to "PORT," you can use input terminals EX1 to EX10 and T11 to T13 to specify the bank.

Bank Select	Details
SEL	The current bank is set as the selected bank on the [Bank Select] screen on the controller.
PORT	The current bank is set as the selected bank with the input terminal.
COMM	The current bank is set as the selected bank through the RS-232C, USB, or Ethernet interface.

Use [Bank Port] and [Bank Width] to set the input terminals to use.

Bank Port	Details
EX1 to EX10 T11 to T13	Starting from the specified terminal, the number of terminals specified with [Bank Width] will be used to set the bank number.

Bank Width	Details
1b:0-1	One terminal is used to select the bank. You can select bank 1 or bank 2.
2b:0-3	Two terminals are used to select the bank. You can select from bank 1 to bank 4.
3b:0-7	Three terminals are used to select the bank. You can select from bank 1 to bank 8.
4b:0-15	Four terminals are used to select the bank. You can select from bank 1 to bank 16.
5b:0-31	Five terminals are used to select the bank. You can select bank 1 to bank 32.

The relationship between the bank numbers and the input terminals is shown below.

For parity, use the ready output terminal.

Bank number	Expansion I/O input EX					Parity
	n	n + 1	n + 2	n + 3	n + 4	
1	OFF	OFF	OFF	OFF	OFF	ON
2	ON	OFF	OFF	OFF	OFF	OFF
3	OFF	ON	OFF	OFF	OFF	OFF
4	ON	ON	OFF	OFF	OFF	ON
5	OFF	OFF	ON	OFF	OFF	OFF
6	ON	OFF	ON	OFF	OFF	ON
7	OFF	ON	ON	OFF	OFF	ON
8	ON	ON	ON	OFF	OFF	OFF
9	OFF	OFF	OFF	ON	OFF	OFF
10	ON	OFF	OFF	ON	OFF	ON
11	OFF	ON	OFF	ON	OFF	ON
12	ON	ON	OFF	ON	OFF	OFF
13	OFF	OFF	ON	ON	OFF	ON
14	ON	OFF	ON	ON	OFF	OFF
15	OFF	ON	ON	ON	OFF	OFF
16	ON	ON	ON	ON	OFF	ON
17	OFF	OFF	OFF	OFF	ON	OFF
18	ON	OFF	OFF	OFF	ON	ON
19	OFF	ON	OFF	OFF	ON	ON
20	ON	ON	OFF	OFF	ON	OFF
21	OFF	OFF	ON	OFF	ON	ON
22	ON	OFF	ON	OFF	ON	OFF
23	OFF	ON	ON	OFF	ON	OFF
24	ON	ON	ON	OFF	ON	ON
25	OFF	OFF	OFF	ON	ON	ON
26	ON	OFF	OFF	ON	ON	OFF
27	OFF	ON	OFF	ON	ON	OFF
28	ON	ON	OFF	ON	ON	ON
29	OFF	OFF	ON	ON	ON	OFF
30	ON	OFF	ON	ON	ON	ON
31	OFF	ON	ON	ON	ON	ON
32	ON	ON	ON	ON	ON	OFF

## 8-3-7 OK/NG Output

Output the result of image capture and processing with the trigger mode.

Normally, only OK output or NG output is set to ON.

You can use [Output Logic] to invert the OK/NG output result. You can also use [Window OR] to change the judgment conditions.

Output Logic	Window OR	Judgment condition	OK output	NG output
Normal	Off	OK in all inspection windows	<b>ON</b>	OFF
		NG in at least one inspection window	OFF	<b>ON</b>
	On	OK in at least one inspection window	<b>ON</b>	OFF
		NG in all inspection windows	OFF	<b>ON</b>
Invert	Off	OK in all inspection windows	OFF	<b>ON</b>
		NG in at least one inspection window	<b>ON</b>	OFF
	On	OK in at least one inspection window	OFF	<b>ON</b>
		NG in all inspection windows	<b>ON</b>	OFF

You can select "level output" or "one-shot output" for the OK/NG output.

Also, to match the output timing with the side that will receive the OK/NG signal, you can set [OKNG On-Delay] or [OKNG Off-Delay].

Level output

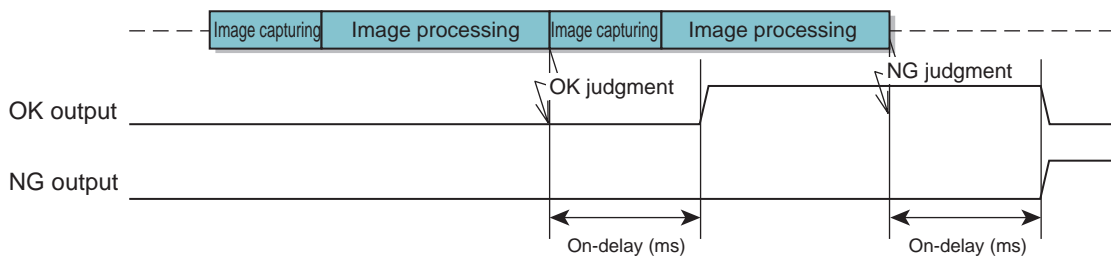

One-shot output

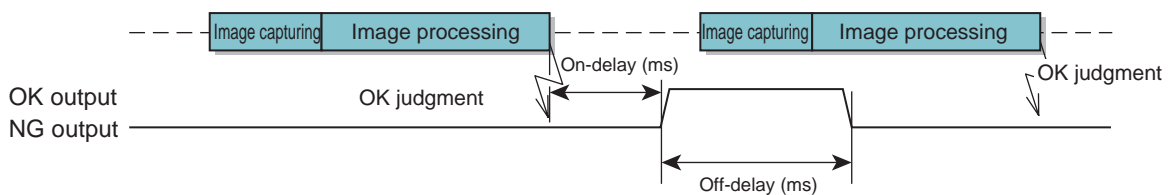

The maximum on-delay time is 5 seconds. Do not set this value so that it is longer than the processing time until the next judgment result.

Doing so will lead to the OK/NG output being canceled and will prevent OK or NG from being output normally.

Level output When a NG judgment occurs during the on-delay of the OK output

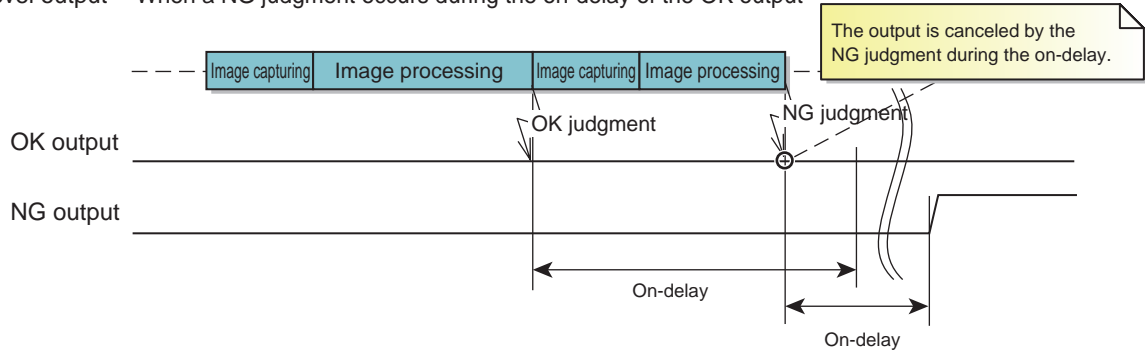

One-shot output When a NG judgment occurs during the on-delay of the OK output

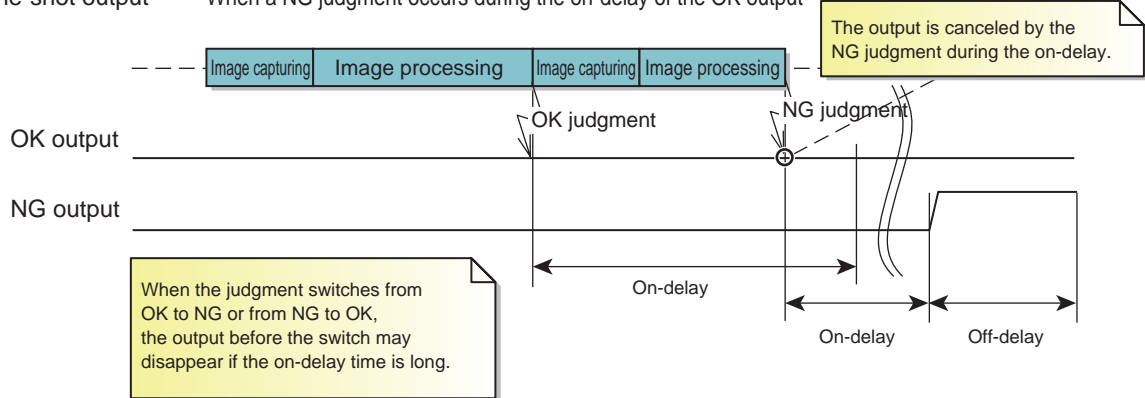

When the OK/NG output is set to "Shift," output will also be output when a judgment occurs during on-delay time or during off-delay time.

Shift output

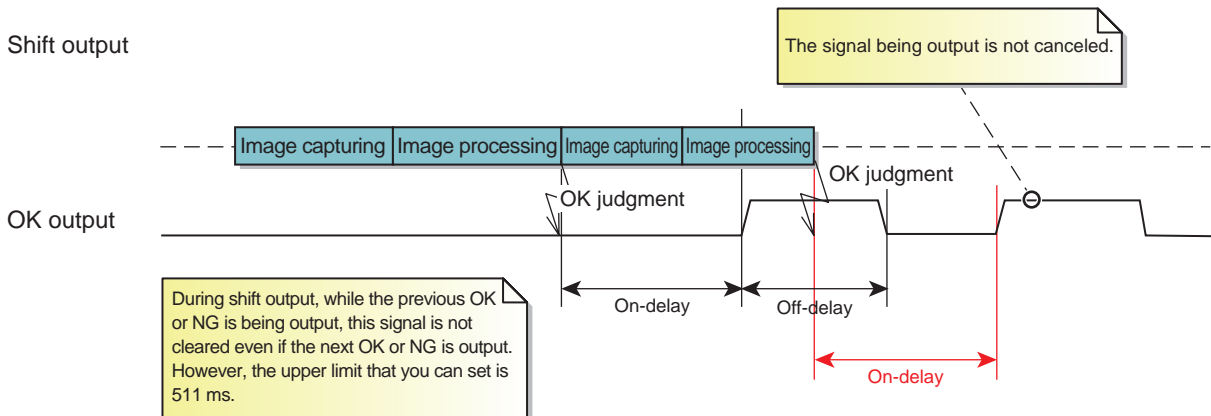

If you change the [OKNG One-Shot] setting during operation, the output will be output as shown below.

Switching from level output to one-shot output while the output is ON

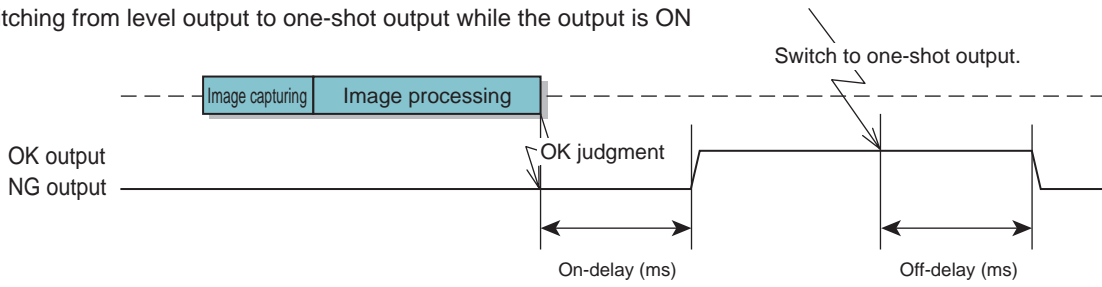

Switching from level output to one-shot output while the output is ON

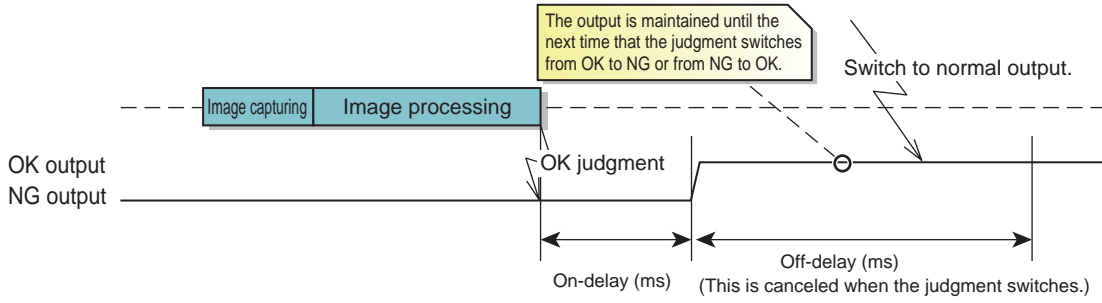

OKNG One-Shot	Details
Off	The OK/NG output will be output using level output.
On	The OK/NG output will be output using one-shot output.
Shift	The OK/NG output will be output using one-shot output and shift output. The on-delay upper limit is 511 ms.

OKNG On-Delay	Details
0 to 5000	Set the time, in units of 1 ms, to wait before setting the OK/NG output to ON.

OKNG Off-Delay	Details
0 to 5000	Set the time, in units of 1 ms, to wait before changing the OK/NG output from ON to OFF.

## 8-3-8 Output Shift

Use this setting to delay the timing when the OK/NG output is set to ON until after the number of image captures set here are completed.

Use this setting when the output process is after the detection location.

Output shift (example: one time)

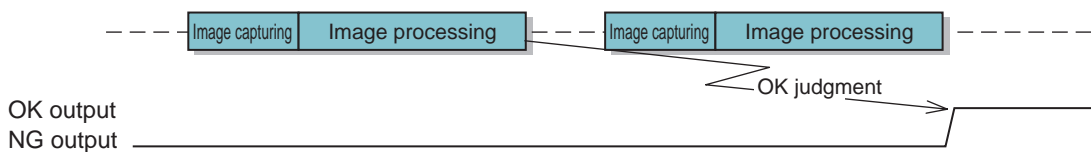

Output Shift	Details
0 to 63	Use this setting to delay the timing when the OK/NG output is set to ON by the number of image captures set here.

## 8-3-9 NG Filter

Set NG output to ON only when the number of consecutive NG judgments exceeds this value.

Use this setting when consecutive NG judgments occur such as when a stamp is out of ink or the printer's date setting is incorrect.

NG output filter (example: one time)

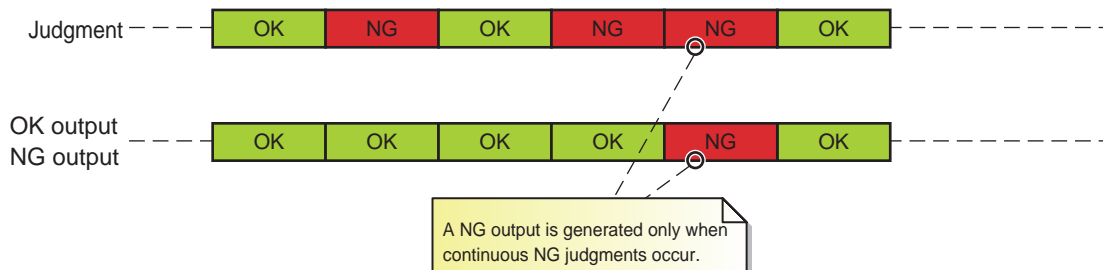

NG Filter	Details
0 to 255	When the number of consecutive NG judgments reaches this value, NG is output.

You can also enable the NG output filter when the set number of OK judgments occur across multiple windows. When the filter is disabled, NG outputs are output immediately when an NG judgment occurs.

Count of OK results to enable the NG filter (OK result count = 3, NG filter = 1)

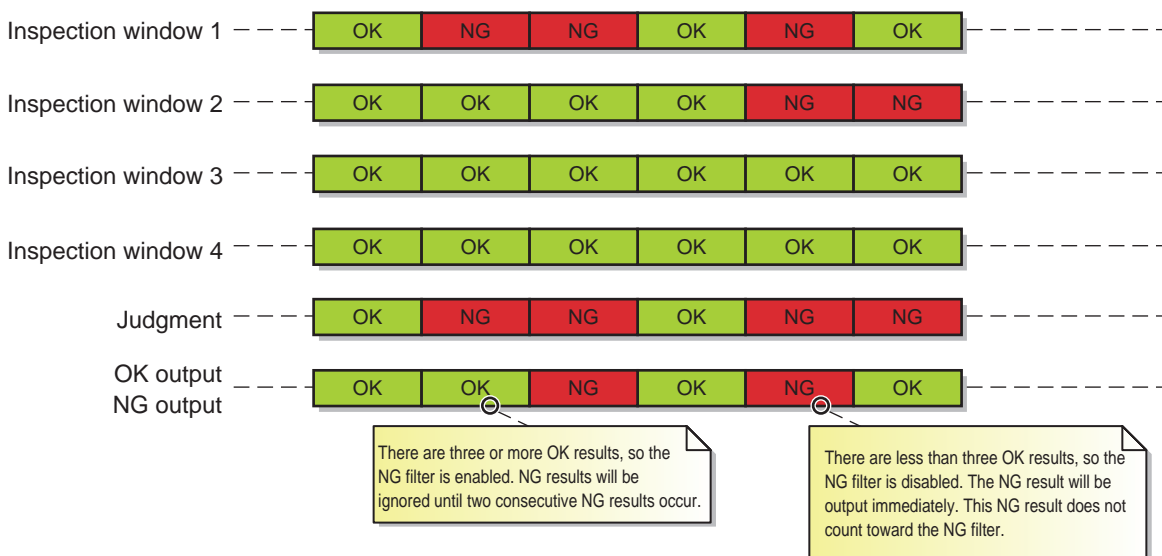

NG Filter OK Count	Details
0 to 63	Set the number of OK formats to enable the NG filter. If the number of OK formats is less than this value, the NG filter will be disabled.

## 8-3-10 Output Reset

On the rising edge of the input, the OK/NG output is set to OFF.

The expansion output terminal will be maintained in this state.

When the OK/NG output is set to one-shot output, it will not be set to OFF during one-shot output.

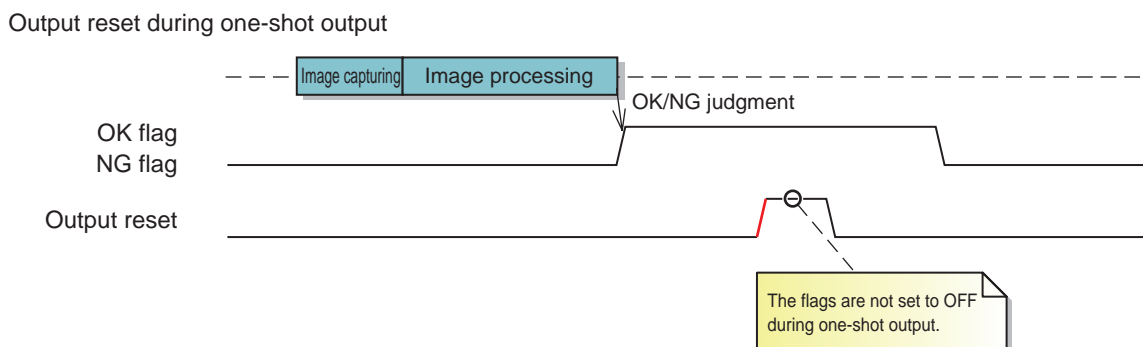
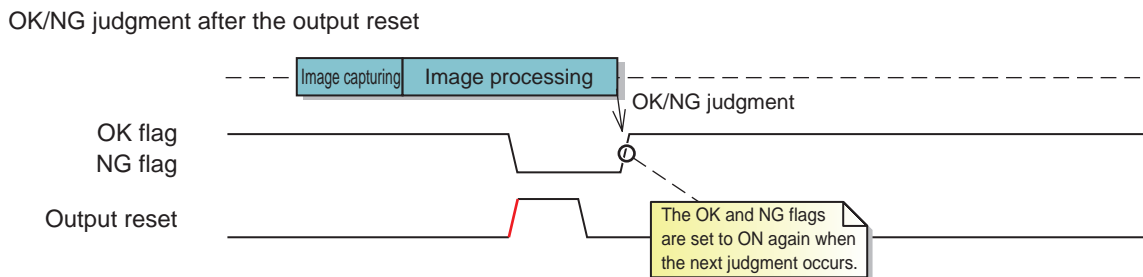
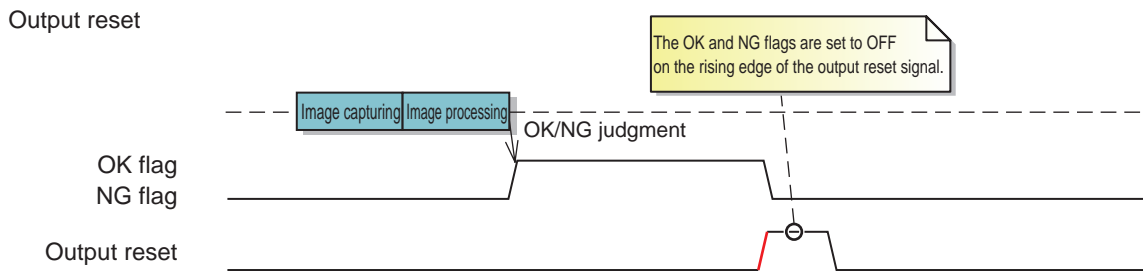

Output Reset	Details
Off	This function will not be used.
EX1 to EX10 T11 to T13	On the rising edge of the corresponding terminal's signal, the OK/NG output will be set to OFF.

## 8-3-11 Batch Trigger Output

Use trigger modes to capture a set number of images. Then perform the set number of image processing operations as a batch.

For example, use this function when you are capturing multiple images while packing materials are moving and only output OK/NG when the packing materials stop moving. An example of such a situation is when you are using a high-speed, deep-drawing packaging machine.

The result of the set number of OK/NG outputs will be grouped together as a batch and output.

You can output the OK/NG results from the expansion I/O output terminals. You can also select "level output" or "one-shot output" to use with the expansion I/O output terminals.

The judgment count will be cleared on the rising edge of the terminal specified with Batch Trigger Reset. When the judgment count is cleared, the results up to that point will be cleared without being output.

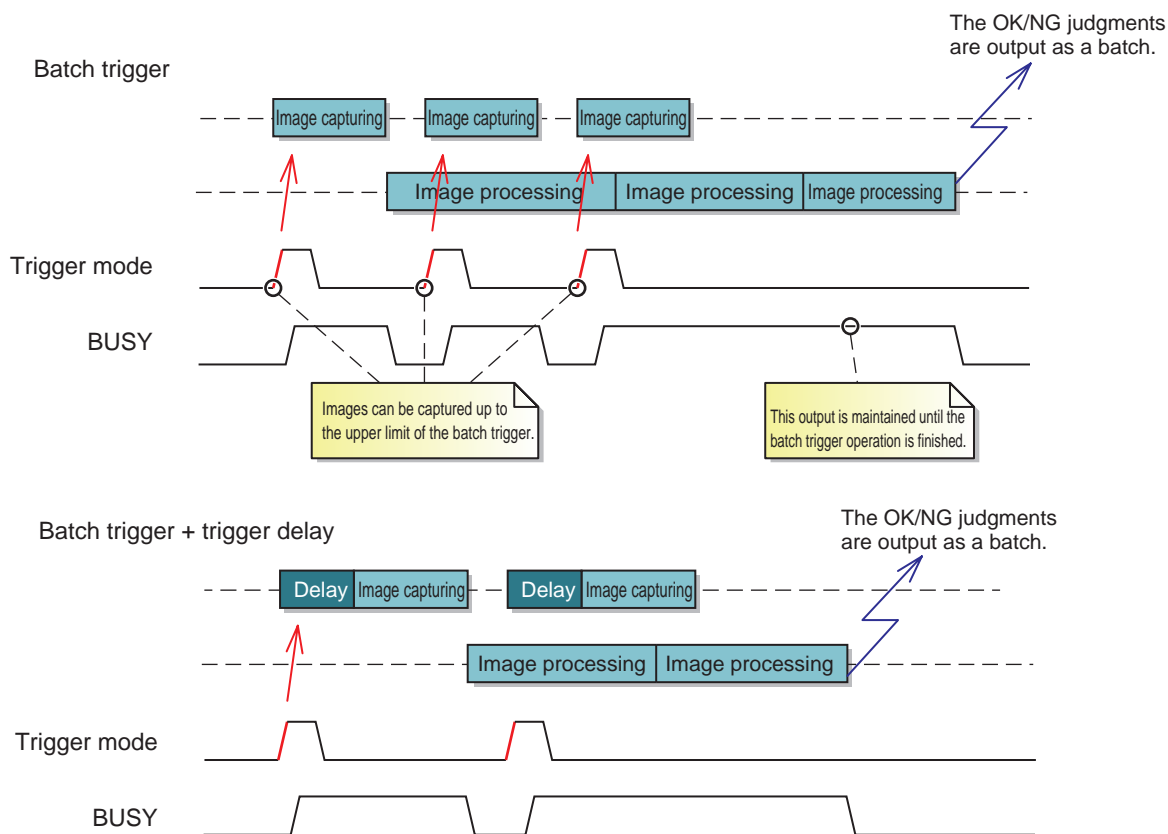

Batch Trigger	Details
0	This function will not be used.
1 to 8	After the specified number of image processing operations are finished, the OK/NG result will be output.

BatchTrg Port	Details
EY1 to EY20	During OK/NG output, each terminal will output its image processing result. The number of terminals specified with Batch Trigger will be assigned starting from the specified terminal.

BatchTrg One-Shot	Details
Off	The batch trigger output terminal uses level output.
On	The batch trigger output terminal uses one-shot output.

BatchTrg Polarity	Details
Normal	If the image processing result whose number is set by the batch trigger output terminal is OK, output will be set to ON.
Invert	If the image processing result whose number is set by the batch trigger output terminal is NG, output will be set to ON.

Batch Trigger Reset	Details
Off	This function will not be used.
Invert	The judgment count will be cleared on the rising edge of the set terminal. When the judgment count is cleared, the results up to that point will be cleared without being output.

(Example) If Batch Trigger = 4 and BatchTrg Port = EY1

Terminals to use = EY1 to EY4

If judgments 1, 2, and 4 are OK and judgment 3 is NG, the terminals will be set as shown in the following table.

EY1	EY2	EY3	EY4
ON	ON	OFF	ON

## 8-3-12 Ready Output

After the device turns on, this output is set to ON when the device is operating.

After the device turns on

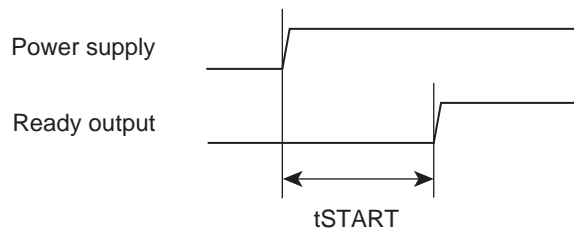

Symbol	Explanation	Time
tSTART	This is the time from the device turning on to the ready output being set to ON.	1.7 s maximum

It is set to OFF when operations stop.

The timing with which this output is set to OFF is shown below.

- Switching the bank

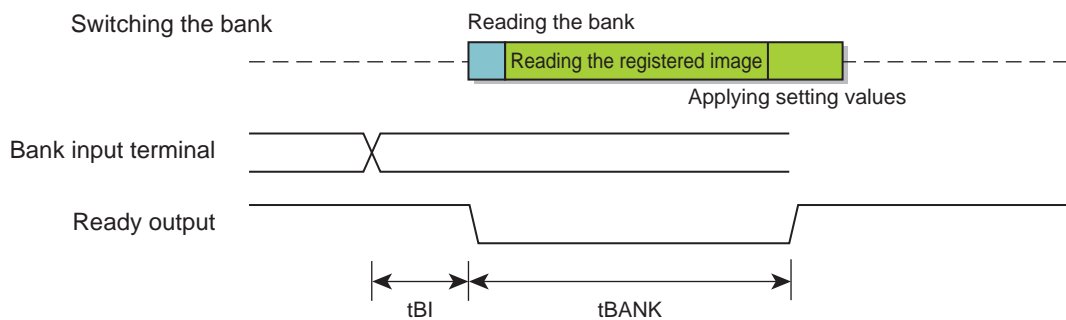

Symbol	Explanation	Time
tBI	The time from the bank input terminal switch to the ready output being set to OFF.	202 ms maximum
tBANK	The time from the ready output being set to OFF to the ready output being set to ON again.	370 ms maximum

- When switching to the following screens

Setup, Teach, External Teaching, Input Test, Output Test, Analyze, and Initialize

## 8-3-13 Busy Output

This output is set to ON during image capturing and image processing. While the busy output is ON, trigger mode signals are not received.

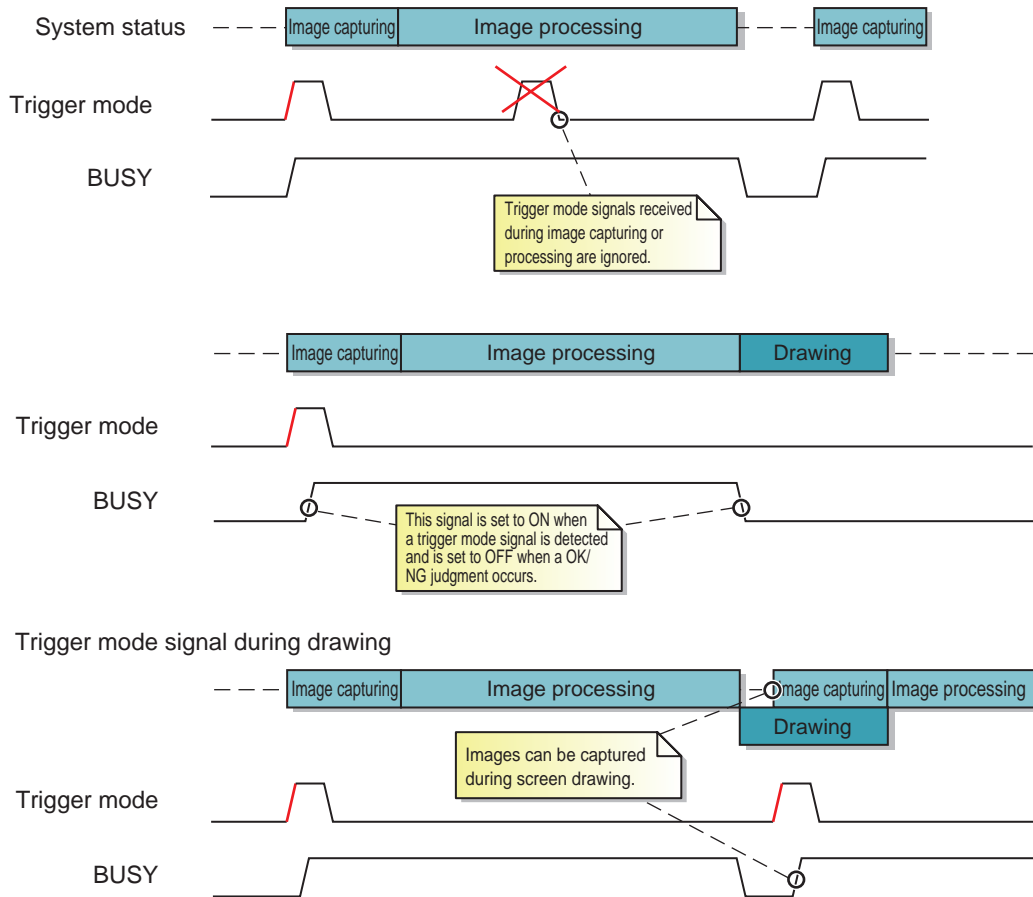

## 8-3-14 String Add

On the rising edge of the input terminal, the character string of inspection window 1 will be incremented by 1. This function is enabled when a character string is included in the format selected for inspection window 1. A value—0 to 9—or a character—A to Z—in the character string will be incremented or decremented by 1. You can select the terminal to use from EX1 to EX10 and T11 to T13.

If [Str Add Mode] is set to "Up Down" or "WithSave," two terminals will be used.

(Example) Addition = EX1, subtraction = EX2

If [String Add] is set to "WithSave," the character string will be saved each time that addition or subtraction is performed.

With any other setting, the addition and subtraction information will be deleted when the device is turned off.

If the character string is "999," "ZZZ," or any other character string that cannot be incremented because carrying cannot be performed, the character string will be adjusted appropriately. For the above two examples, the resultant character strings will be "000" and "AAA" respectively.

Borrowing is performed in the same manner. When borrowing is performed on "000" and "AAA," the resultant character strings are "999" and "ZZZ" respectively.

String Add	Details
Off	This function will not be used.
EX1 to EX10 T11 to T13	Select the terminal to use during character string addition. If [Str Add Mode] is set to "Up Down" or "WithSave," two terminals will be used.

Str Add Mode	Details
Count Up	On the rising edge of the input terminal, character string addition will be performed. When the device is turned off, the addition information will be deleted.
Up Down	On the rising edge of the terminal specified with [String Add], character string addition will be performed. On the rising edge of the terminal after that specified with [String Add], character string subtraction will be performed. When the device is turned off, the addition and subtraction information will be deleted.
WithSave	Character string addition and subtraction will be enabled. Even when the device is turned off, the addition and subtraction information will not be deleted.

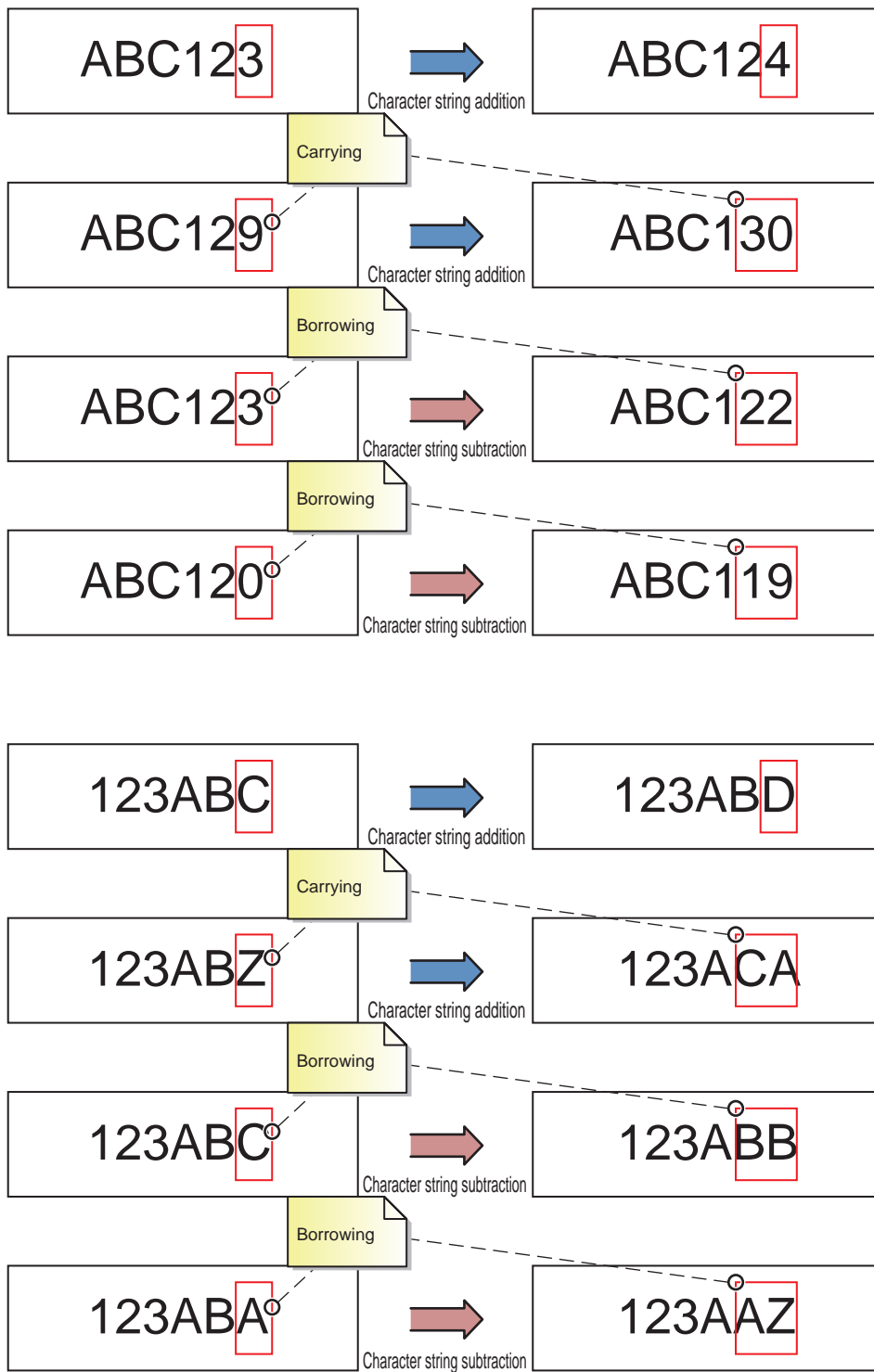

## 8-3-15 Str Add Reset

On the rising edge of the specified terminal, the character string will be returned to its previous state. When [Str Add Mode] is set to "WithSave," this function is disabled.

Str Add Reset	Details
Off	This function will not be used.
EX1 to EX10 T11 to T13	When the corresponding terminal turns on, the character string addition/subtraction result will be cleared.

## 8-3-16 Window Output

Output the inspection window judgment results from an expansion output. If you are using batch triggers, only the final judgment result will be output.

Window Port	Details
EY1 to EY20	The OK/NG judgments will be output for each inspection window during OK/NG output. The number of terminals specified with Window Width will be assigned starting from the specified terminal.

Window Width	Details
Off	This function will not be used.
1bit to 4bit	Set the number of inspection windows to output. Inspection windows that are not in use will not be output. 1: Inspection window 1 2: Inspection window 1 and inspection window 2 3: Inspection window 1 to inspection window 3 4: Inspection window 1 to inspection window 4



---

# 9

## **Troubleshooting**

This chapter explains the causes of and solutions for problems that occur during use.

# 9-1 Problems and Solutions



## 9-1-1 Problems Indicated by the Camera Unit

### Indicators

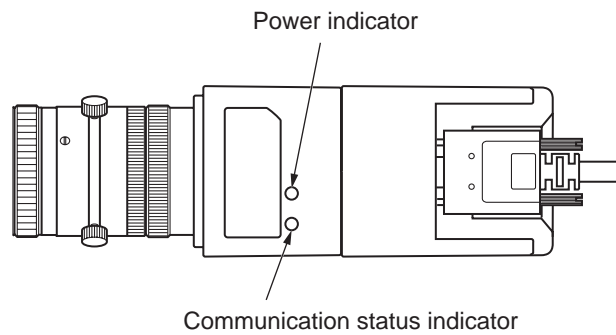

Symptom	Cause	Solution	Reference page
The power indicator is off.	There is no power to the controller.	Ensure that the power supply is connected to the controller.	2-16
	The camera cable is not connected.	Securely connect the camera cable.	2-14
The communication status indicator (which indicates normal operation when lit in green) is: <ul style="list-style-type: none"> <li>• Blinking in green.</li> <li>• Lit or blinking in orange.</li> <li>• Lit or blinking in red.</li> </ul>	An error has occurred during communication.	Contact an Optex FA sales representative or Optex FA customer support.	—

## 9-1-2 Image Capture Problems

Symptom	Cause	Solution	Reference page
The captured image is blurred or out of focus.	The shutter speed setting is not correct.	If the shutter speed is too slow, a blurred image may be captured. Try to set the [Shutter Speed] setting to a faster value.	6-8
	The lens is out of focus.	Adjust the focus ring of the lens to bring into focus the object whose image is being captured.  <b>Caution</b> There are locking screws for fixing in place the focus and iris rings of the lens. When the locking screws are fixed in place, in general, there are no problems with the focus and iris, so do not touch these rings unless necessary.	—
The print position within the field of view does not stabilize.	The print position of the printer is not stable.	You may be able to deal with a variety of print positions by performing continuous image capture. Configure the [No. of CntShot] and [CntShot Timer] settings in order to try continuous image capture.	6-8
	Trigger mode signals are not stable.		



## 9-1-3 Lighting Problems

Symptom	Cause	Solution	Reference page
Lighting does not turn on.	The lighting connections are not correct.	Check the connector that the lighting is connected to, and then connect the lighting correctly.	2-15
	The lighting output settings are not correct or are not appropriate.	Check the output destination setting specified with [Light Outputs]. Also check that [Light#1 Bright] to [Light#3 Bright] are not set to values that are too low.	6-11

## 9-1-4 Teaching Problems

Symptom	Cause	Solution	Reference page
Characters are not split from each other correctly during teaching.	Characters are printed too close together.	Increase the space between characters.	6-18

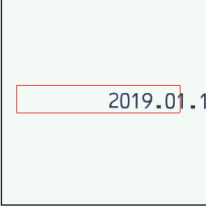
## 9-1-5 I/O Problems

Symptom	Cause	Solution	Reference page
No output is generated from the camera unit.	There is a connection problem with an external device connected to the controller.	Perform an output test to the external device connected to the controller. If signals do not reach the externally connected device regardless of the output status, check the wiring and the program.	6-55
Trigger mode signals do not reach the camera unit.	There are no trigger mode signals from the externally connected device.	Perform an input test to the controller from the externally connected device. If the corresponding input indicator does not light, check the wiring and the program.	6-54
The bank is not changed by way of an external signal.	The set input method for selecting the bank is not correct.	Check that [Bank Select] is set to "PORT."	6-47
[Bank Select] is set to "PORT," but the bank is not switched or the bank is only switched to some banks.	The settings for the bank input terminal and the number of terminals are not correct.	Check that the terminal number specified with [Bank Port] is correct and that the number of terminals to use specified with [Bank Width] matches the bank to be switched to.	6-47
The bank is not switched to the correct bank.	The set bank input terminal and the actual wiring do not match.	Check that the terminal number specified with [Bank Port] and the actual wiring match.	6-47
The inspection timing is off.	There is a problem with the trigger mode sensor.	The connected trigger mode sensor may be malfunctioning, so inspect and adjust it.	—
	The image is captured before the printed details can enter the screen.	 <p>Set [Trigger Delay] (ms) to delay the shutter timing.</p>	6-47
	The image is captured after the printed details have passed by.	 <p>Adjust the installation position of the trigger mode sensor or of the camera.</p>	—
No judgment output is generated from the camera unit.		With the initial settings, after judgment is performed and output is generated, the output is maintained until the opposite (OK or NG) judgment result occurs. If you want to change this behavior so that output is set to OFF after a prescribed amount of time, set [OKNG One-Shot] to "On," and then use [OKNG Off-Delay] to set the time to maintain output.	6-51

# 10

## **Appendix**

This appendix contains the specifications and dimensions of the device.

# 10-1 Specifications

## ■ Camera unit

Item	Specifications
Model	MVS-OCR2 digital CMOS character recognition camera unit
Power supply voltage	6 VDC (supplied by the controller)
Current consumption	Maximum 200 mA/24 VDC (current value of the controller)
Image sensor	1-megapixel, 1/1.8-inch, CMOS color image sensor
Resolution	1024 × 1024 pixels, progressive scan
Effective pixel region	5.42 (horizontal) × 5.42 (vertical) mm
Lens mount	C mount
Communication interface	LVDS, 100 Mbps (dedicated for use with the controller)
Communication cable length	2 m, 5 m, 10 m (straight connector), 5 m (right-angle connector)
Indicators	Power indicator LED, communication status indicator LED
Reply time	Approximately 48 ms (when recognizing a 2-line date with 20 characters, no searching, and no rotation correction)*
Number of recognized characters	60 characters/6 lines
Number of characters per line	60
Minimum character width	1.5 mm with a field of view of 100 mm (typical value)
Minimum character height	3.0 mm with a field of view of 100 mm (typical value)
Kanji characters	Cannot be recognized
Number of inspection windows	4 maximum
User-defined dictionary (extended dictionary)	1500 characters managed in 3 groups of 500 characters each
Recognition of encrypted dates and times	The month can be switched to 1 or 2 alphanumeric characters, the day can be switched to 2 alphanumeric characters, the hour value can be switched to 1 alphanumeric character, and the minute value can be switched to 1 alphanumeric character.
Number of banks	32
Number of saved NG images	90 (raw images), cannot be displayed during operation
Display of saved images during operation	Raw images/judgment images (10) can be displayed.
Operating temperature/humidity	0 to +50°C/35 to 85%RH (no condensation)
Storage temperature/humidity	-20 to +70°C/25 to 95%RH (no freezing or condensation)
Vibration resistance	10 to 55 Hz; double amplitude 1.5 mm; 2 hours in each of the X, Y, and Z directions
Shock resistance	Approximately 15 G; 3 times in each of the X, Y, and Z directions
Applicable regulations	EMC Directive (2004/108/EC), RoHS Directive (2011/65/EU)
Applicable standards	EN61000-6-2, EN61000-6-4
Material	Aluminum alloy
Protection category	IP50
Weight	Approximately 140 g
Accessory	Mounting bracket

\* This varies according to settings such as the shutter speed and the inspection window size.

## ■ Controller

Item	Specifications
Model	MVS-DN (NPN specifications) MVS-DN-E (NPN specifications, Ethernet support) MVS-DP (PNP specifications) MVS-DP-E (PNP specifications, Ethernet support) 4.3-inch, TFT, touch panel LCD controller
Power supply voltage	24 VDC ±10% (Operations are possible with 12 VDC when the external lighting output is not used.)
Current consumption	Controller: Maximum 80 mA/24 VDC (maximum 110 mA/24 VDC for models with Ethernet support) When using external lighting output: Maximum 1.5 A (lighting power consumption × 150%) The current consumption for each of the connected cameras is added to the above values.
Number of camera connections	3 maximum
Output signals	NPN/PNP open collector output, residual voltage: 1.0 V or less OK/NG: 1 pass signal and 1 fail signal per camera (6 signals total), 100 mA maximum Expansion output: 20 signals total, 50 mA maximum
Input signals	Trigger mode: 3 signals, expansion output: 10 signals
I/O connectors	Power, pass, fail, trigger mode: 12-pin dedicated terminal block Expansion I/O: 50-pin IEEE1284 half-pitch interface connector
External lighting output	12 V, PWM control (87 kHz, resolution: 256) 3 outputs, 24 W total
Communication interface	USB 1.1 (12 Mbps maximum): Standard USB connector RS-232C (500 kbps maximum): D-sub 9-pin Models with Ethernet support: Ethernet (10BaseT/100BaseTX) RJ45 (8P8C) connector
Display and operating devices	4.3 inches wide, TFT LCD; touch panel; panel switches; power LED; head selection LEDs
Built-in clock accuracy	-45 seconds to +1 minute and 15 seconds a month (typical value)
Built-in clock backup	Primary battery: 5 years with the power turned off (typical value) Supercapacitor: 7.8 years
Operating temperature/humidity	0 to +50°C/35 to 85%RH (no condensation)
Storage temperature/humidity	-20 to +70°C/25 to 95%RH (no freezing or condensation)
Vibration resistance	10 to 55 Hz; double amplitude 1.5 mm; 2 hours in each of the X, Y, and Z directions
Shock resistance	Approximately 10 G; 3 times in each of the X, Y, and Z directions
Applicable regulations	EMC Directive (2004/108/EC), RoHS Directive (2011/65/EU)
Applicable standards	EN61000-6-2, EN61000-6-4
Material	Polycarbonate
Protection category	IP20
Weight	Approximately 570 g Models with Ethernet support: Approximately 595 g
Accessories	12-pin dedicated terminal block, panel mount attachments

# 10-2 Dimensions

## ■ Camera unit

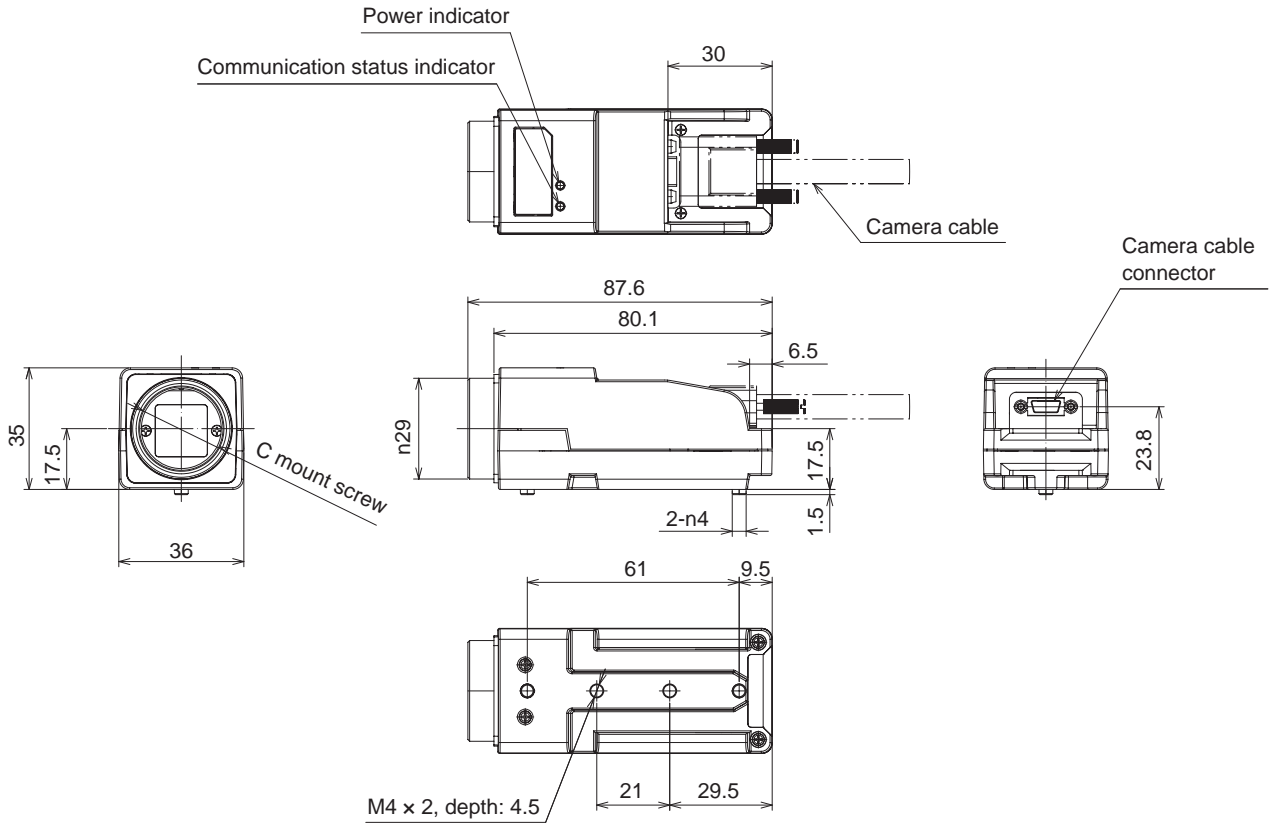

## ■ Controller

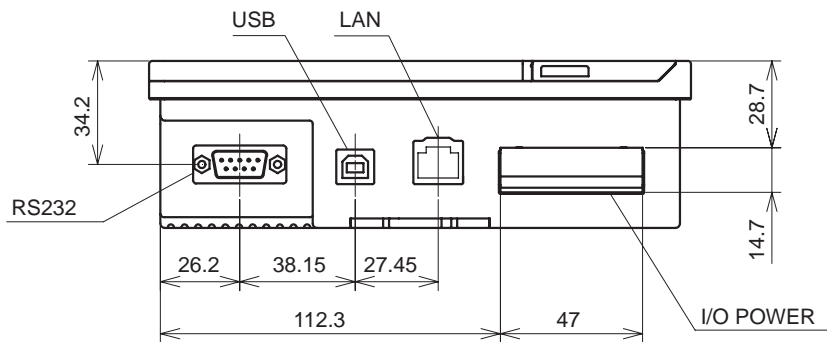
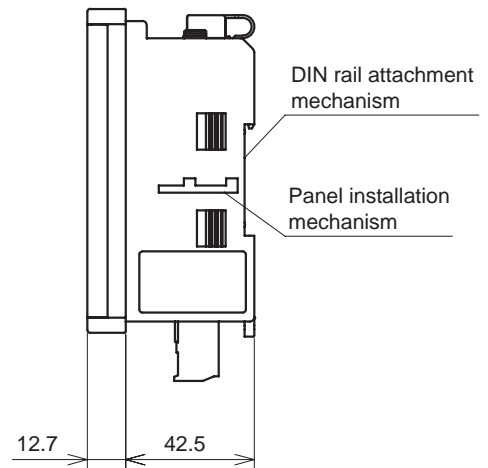
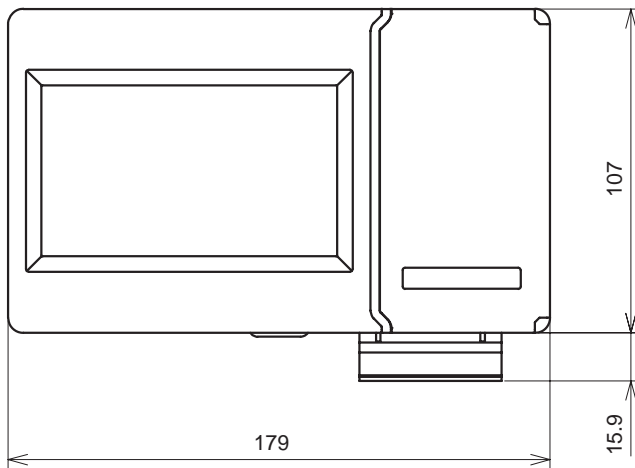
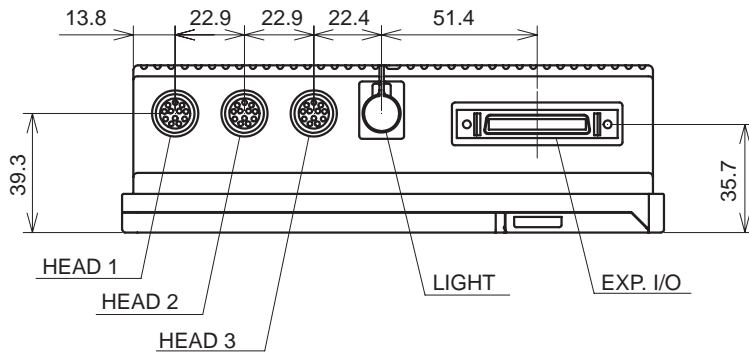



# Index

## Symbols

[Bank Chg.] key .....	3-6
[Main Menu] key .....	3-6
[Settings] menu .....	3-5
[System] menu .....	3-5

## Numerals

0 Suppress .....	6-25
2-Compressed .....	6-70
2-Screen Lock .....	6-70
7 × 7 characteristic display .....	3-7

## A

Active Table .....	7-23
Allow : .....	6-25
Allow .....	6-25
Allow / .....	6-25
Allow Leap Year .....	6-30
ASCII code table .....	8-23
Auto Dictionary .....	6-26
Auto Dict. Level .....	6-26

## B

BackLightTimer .....	6-70
bank .....	4-4, 8-45
bank comment .....	5-5
Bank Copy .....	5-3
bank number .....	3-6
Bank Port .....	6-48
bank-registered image .....	6-16
Bank Select .....	6-48
bank selection .....	7-33
Bank Width .....	6-48
barcode data .....	7-19
Barcode Data .....	7-23
Barcode Link .....	7-22
barcode link function .....	7-13
BatchTrg One-Shot .....	6-54
BatchTrg Polarity .....	6-54
BatchTrg Port .....	6-54
batch trigger .....	8-58
Batch Trigger .....	6-54

Batch Trigger Reset .....	6-49, 8-52
Baud rate .....	7-22
Baud Rate .....	6-70
B-Code Table Setting .....	7-19
BCR NG IN .....	7-23
Bg. Filter .....	6-19
Bolding .....	6-19
Brightness .....	6-9
Built-in Dict. .....	6-26
Busy Enable .....	6-53
Busy Port .....	6-53

## C

CalendarOffset .....	6-30
calendar timer .....	6-68
camera cable .....	1-3, 2-3, 2-5, 2-14
camera image display .....	3-3
camera unit .....	1-3
camera unit connector .....	2-6, 2-14
canceling USB mode .....	8-18
captured image .....	6-16
CCTV lens .....	2-3
Change Table IN .....	7-23
Character Analysis .....	6-67
Character Color .....	6-14
character format .....	7-26
Character Gain .....	6-14
character recognition .....	6-23
character string .....	6-31, 7-12, 8-56, 8-58
Char. Count .....	6-25
Char. Height .....	6-19
Char. Width .....	6-19
Check Line Feed .....	6-24
checksum .....	8-22
C-mount lens .....	1-4, 2-5
CntShot Timer .....	6-9
color extraction .....	4-20, 4-23, 6-21
color extraction precision .....	4-24
communication command .....	8-4
communication status indicator .....	2-5, 7-11
communication success rate .....	3-9

configuring and changing settings .....	3-13
control commands .....	7-26
controller.....	1-3, 2-12
controller connector .....	2-14
correlation.....	3-8
Correlation Limit .....	6-65
cursor.....	3-12
cutout.....	6-18
Cutout Level .....	6-19
Cutout mode .....	6-67

## D

data table.....	7-16
Date Offset#1 .....	6-29
Date Offset#2 .....	6-29
Date Order.....	6-24
Date Retry .....	6-30
date settings .....	6-28
Date Tolerance#1 .....	6-29
Date Tolerance#2 .....	6-29
Day 0 Padding.....	6-24
decryption table .....	6-36
dictionary group.....	6-26
Diff Cut.....	6-65
DIN rail.....	2-13
Direction .....	6-9
display of character division and match rates.....	3-7
display of formats 1 to 4 .....	3-8
display of judgment results.....	3-7
display of upper and lower limits on the number of characters...	3-8
Display Window .....	6-69
Dot Checking.....	6-24

## E

edit mode.....	3-13
encoder.....	6-50
Era Year .....	6-25
Ethernet communication.....	8-24
expansion I/O connector.....	2-6, 2-8, 5-8
expansion I/O output status.....	7-19
expansion I/O terminals.....	6-54, 6-55
expansion output terminal status monitor.....	3-9
Exp. Date or character.....	3-8
extended dictionary .....	6-26, 6-43
extension ring .....	1-4, 2-4, 2-5, 2-19

## F

failure analysis.....	5-13
field of view.....	2-17
filter.....	2-5
fitting guide .....	2-14
fixing screws.....	2-11
focus.....	4-11
force release the password lock.....	7-9
Force Trigger .....	6-48
format .....	6-24
Format Analysis .....	6-67

## G

Global Match Level.....	6-26
Gradation.....	6-14
Grad. Low Limit .....	6-14

## H

Head.....	7-19
head communication status monitor.....	3-9
head number display .....	3-6
head output status monitor.....	3-9
Height Limit.....	6-19
Hour 0 Padding.....	6-25

## I

illuminance correction.....	6-15
image capture direction .....	4-9
image, registration .....	4-12
Image saved to memory.....	6-16
image, zooming in on .....	3-3
initialize.....	7-3
input settings .....	6-47
Insert Line Feed.....	6-24
inspection window .....	4-13, 6-57, 6-59
inspection window judgment result.....	3-7
inspection window number display .....	3-6
I/O connector cable .....	2-4, 5-8
I/O status display.....	3-9
iris.....	2-20

## J

judgment image .....	3-3
Judgment Polarity.....	6-26
Judgment result display.....	3-6



## L

LAN port .....	2-6
LED light .....	1-3, 2-15
LED light cable .....	2-4, 2-15
LED light connector .....	2-6, 2-15
level output .....	8-44, 8-47, 8-52
Light Bright .....	6-12
Light Control .....	6-12
lighting cable.....	1-3
Light Outputs .....	6-12
Light Polarity.....	6-12
Light Steady.....	6-12
Limit Corr. ....	3-8

## M

Macro lens with mega-pixel support .....	2-3
Main menu.....	3-4
Max. Length.....	3-8
Max. String Length .....	6-26
Max Str. Length .....	6-67
menu and details display .....	3-4
Min. 0 Padding.....	6-25
Min. Height .....	6-19
minimum character height .....	2-17
minimum character width.....	2-17
Min. Length.....	3-8
Min. String Length .....	6-26
Min. Width.....	6-19
mirrored characters .....	4-9
mixed-product inspection mode.....	7-14, 7-20
Month 0 Padding .....	6-24
Month Abbrev.....	6-25
mounting bracket.....	2-11
Multi Judge .....	5-12, 6-9
MVS-D Seting.....	7-19

## N

NG Filter .....	6-52
NG Filter OK Count .....	6-52
NG images.....	5-11
No Match OUT.....	7-23
No. of CntShot.....	6-9
No. of Day Table .....	6-25
No. of Month Table .....	6-25
No. Of Read.....	3-8

numeric keypad .....	2-6, 3-12
numeric value edit mode .....	3-14

## O

Ocr2Capture .....	5-7, 8-36
OffDelay Time.....	7-23
OKNG On-Delay.....	6-52
OKNG One-Shot.....	6-52
OK/NG output.....	8-47
On Delay Time.....	7-23
OneShot .....	7-23
one-shot output.....	8-44, 8-47, 8-52
operation screen.....	3-6
operation screen of the barcode link function...7-18, 7-25	
operation status display.....	3-6
optics chart .....	2-19
Output Limit .....	6-54
Output Logic .....	6-52, 8-47
Output Reset .....	6-48
output settings .....	6-51
Output Shift.....	6-52
output status display.....	7-19

## P

panel.....	2-12
panel mount attachment.....	2-6, 2-12
parity.....	8-46
pass and failure counts.....	3-7
password .....	7-5
password lock.....	7-7, 7-8
Polarization filter .....	2-3
positioning pin.....	2-11
power and head connection status indicators .....	2-6
power indicator .....	2-5
power supply .....	1-3
preprocessing.....	6-13
processed image .....	3-3
ProcTime .....	3-7

## R

raw image.....	3-3
Rcg. Date or character .....	3-8
reading the recognized character string .....	8-6
reading the recognized character string and the match rate ...8-9	
reading the reference string.....	8-15
Read Strings.....	3-8

Ready Port.....	6-52
Ready Width.....	6-52
recognition results and match rates.....	3-7
Region of Interest.....	6-9
Re-Scanning.....	6-24
Rotation Correction.....	6-19
Rotation Offset.....	6-19
RS-232C terminal.....	2-6

## S

Save Image.....	6-69
screw lock.....	2-14
Search Accuracy.....	6-65
Search Angle.....	6-65
search function.....	6-60
search range.....	6-61
Search Time.....	6-65
select a bank.....	5-2
selecting the bank.....	7-33
serial communication status.....	3-9
settings for image capture.....	6-8
setup menu.....	4-3
shutter speed.....	4-8
Shutter Speed.....	6-9
simple string editing.....	6-34
Slant Analysis.....	6-67
Slant Correction.....	6-20
Slant Offset.....	6-19
Slant Retry.....	6-20
Split X Char.....	6-20
Split Y Line.....	6-20
Stamp.....	6-19
standard mode.....	7-13
Start-up String.....	6-69
status display.....	3-6
Str Add Mode.....	6-49
Str Add Reset.....	6-49
strictness table.....	6-41
String Add.....	6-49
String Lines.....	6-25
switching the bank.....	8-4
switching to USB serial communication mode.....	8-18
Sync Pulse Count.....	6-48, 8-42
Sync Pulse Port.....	6-48, 8-42

## T

Table Select IN.....	7-23
Teaching.....	4-15, 6-66
Teaching OUT.....	7-23
Teach Input.....	6-49
Teach Mode.....	6-67
terminal block.....	2-6, 2-7, 2-16
terminal block output status.....	7-19
Threshold.....	6-14
Time Offset#1.....	6-29
Time Offset#2.....	6-29
Time Tolerance#1.....	6-29
Time Tolerance#2.....	6-29
touch key.....	3-10
touch panel.....	2-6
TrgChk Off-Dly.....	6-53
TrgChk On-Dly.....	6-54
TrgChk One-Shot.....	6-53
TrgChk Port.....	6-53
TrgChk Time.....	6-53
Trigger Check.....	6-53
Trigger Delay.....	6-48
trigger delay time.....	4-7, 8-41
Trigger Filter.....	7-22
TriggerFilter.....	6-54, 8-45
triggering sensor.....	4-5
Trigger Mode.....	6-48
trigger mode setting.....	4-5
trigger mode terminal.....	8-40, 8-43
Trigger Port.....	6-48

## U

unique date.....	6-27
unlock.....	7-9
USB port.....	2-6

## V

Variable Shutter.....	6-9
verification result.....	7-19
verification table.....	7-25
Verify Char Head.....	6-70
VerifyCharSend.....	7-22
Verify Char Store.....	6-70
version.....	7-2
Vertical Printing.....	6-25



Video Output..... 6-70  
Video Screen.....6-70, 7-22

**W**

Window One-Shot ..... 6-53  
Window OR ..... 6-52  
Window Polarity..... 6-53  
Window Port ..... 6-53  
wiring example..... 2-10  
working distance..... 2-18  
writing the reference string to compare ..... 8-11

**X**

X Ave. Pixel ..... 6-14  
X Center Position..... 6-15  
X Dot Period ..... 6-20  
X Sensitivity ..... 6-15  
X Sensor Position ..... 6-9

**Y**

Y angle ..... 6-9  
Y Ave. Pixel ..... 6-14  
Y Center Position..... 6-15  
Y Dot Period ..... 6-20  
Y Sensitivity ..... 6-15









---

**Attention: Not to be Used for Personnel Protection.**

Never use these products as sensing devices for personnel protection. Doing so could lead to serious injury or death. These sensors do not include the self-checking redundant circuitry necessary to allow their use in personnel safety applications. A sensor failure or malfunction can cause either an energized or de-energized sensor output condition. Please consult our distributors about safety products which meet OSHA, ANSI and IEC standards for personnel protection.

- Specifications are subject to change without prior notice.
- Specifications and technical information not mentioned here are written in Instruction Manual. Or visit our website for details.
- All the warnings and cautions to know prior to use are given in Instruction Manual.



**OPTEX FA CO., LTD.**

600-8815 Kyoto, Shimogyo, Chudoji Awata 91, Japan  
TEL. +81-(0)75-325-1314 FAX. +81-(0)75-325-2921  
<http://www.optex-fa.com>