

IO-Link GATEWAY

UC2-IOL

Download the index list, the IO-Link setting file (Iodd file) and the connected module operation manual from the Optex FA website.
<https://www.optex-fa.com>



OPTEX FA CO., LTD.

- Thank you for purchasing this IO-Link Gateway UC2-IOL.
- Before using this product, please read this manual carefully to ensure proper use.
- Read this manual thoroughly, and then keep this manual at hand so that it can be used whenever necessary.

Safety Precautions

Safety precautions for ensuring safe operation of this product are displayed as follows with the following symbols.

Precautions listed here describe important information about safety. Make sure to follow them accordingly.

Safety Symbols

	WARNING Indicates that any improper operation or handling may result in moderate or minor injury, and in rare cases, serious injury or death. Also indicates a risk of serious property damage.
	CAUTION Indicates that any improper operation or handling may result in minor injury or property damage.

WARNING	
	Do not disassemble, repair, modify, deform under pressure, or attempt to incinerate this product. Doing so may cause injury or fire.
	This product is not explosion-proof and should not be used around flammable or explosive gases or liquids. Doing so may cause ignition resulting in an explosion or fire.
	Do not use air dusters or any spray that uses flammable gas around the product or on the inside of the product. Doing so may cause ignition resulting in an explosion or fire.
	Do not install this product in any of the following locations. Doing so may cause a fire, damage, or a malfunction. <ol style="list-style-type: none"> 1. Locations where dust, salt, iron powders, or vapor (steam) is present. 2. Locations subjected to corrosive gases or flammable gases. 3. Locations where oil or chemical splashes may occur. 4. Locations where heavy vibrations or impacts may occur. 5. Locations where the ambient temperature exceeds the rated range. 6. Locations subject to rapid temperature changes (or where condensation occurs). 7. Locations with strong electric or magnetic fields. 8. Outdoor locations or locations subject to direct light.
	This is a class A product. In a domestic environment this product may cause radio interference, in which case the user may be required to take adequate measures.
	This product is not intended for use with nuclear power, railways, aviation, vehicles, medical equipment, food-handling equipment, or any application where particular safety measures are required. Absolutely do not use this product for any of these fields.
	This product cannot be used in applications that directly or indirectly detect human bodies for the purpose of ensuring safety. Do not use this product as a detection device for protecting the human body.
	What to do in the event of a malfunction such as smoke being emitted from the product if you detect any malfunction including emission of smoke, abnormal smells or sounds, or the body becoming very hot, immediately stop operating the product and turn off the sensor power. Failure to do so may cause a fire. Repairing the product is dangerous and should in no way be performed by the customer. Contact an OPTEX FA sales representative for repairs.

CAUTION	
	Make sure to turn the power off before wiring the cable or connecting/disconnecting the connector. Connecting or disconnecting while energized may damage the product or cause electric shock.
	Do not wire with high voltage cables or power lines. Doing so may cause malfunction or damage by induction.
	Do not bend the cable when below the freezing point. This may cause the cable to break.
	Do not drop the product or subject the product to strong impacts. Doing so may damage the product.
	Follow the instructions in this manual or the specified instruction manual when wiring the product or the dedicated controller for the correct wiring method. Incorrect wiring can damage the product or the controller, or cause a malfunction.
	When disconnecting the connector, be careful not to touch the terminals inside the connector, and do not allow foreign objects to enter the connector.
	Install this product as far away as possible from high-voltage equipment, power equipment, equipment that generates large switching surges, inverter motors, welders, or any equipment that can be a source of noise.
	When connecting or disconnecting the cable, make sure to hold it by the connector portion, and do not apply excessive force to the cable.
	If this product is used in a manner not specified by the manufacturer, the protection provided by this product may be impaired.

NOTICE

- After carefully considering the intended use, required specifications, and usage conditions, install and use the product within the specified ranges.
- All specifications may be changed without notice.
- When using this product, it is the responsibility of the customer to ensure necessary safety designs in hardware, software, and systems in order to prevent any threat to life, physical health, and property due to product malfunction or failure.
- Do not use this product for the development of weapons of mass destruction, for military use, or for any other military application. Moreover, if this product is to be exported, comply with all applicable export laws and regulations, including the "Foreign Exchange and Foreign Trade Act" and the "Export Administration Regulations," and carry out the necessary procedures pursuant to the provisions therein.
- For more details on conformity to the Restriction of Hazardous Substances Directive for this product, please contact an OPTEX FA sales representative. Before using this product, fully examine the applicable environmental laws and regulations, and operate the product in conformity to such laws and regulations. OPTEX FA does not assume any responsibility for damages or losses occurring as a result of noncompliance with applicable laws and regulations.

1. Included Accessories

- Instruction manual (this manual)

2. Dimensions

UC2-IOL

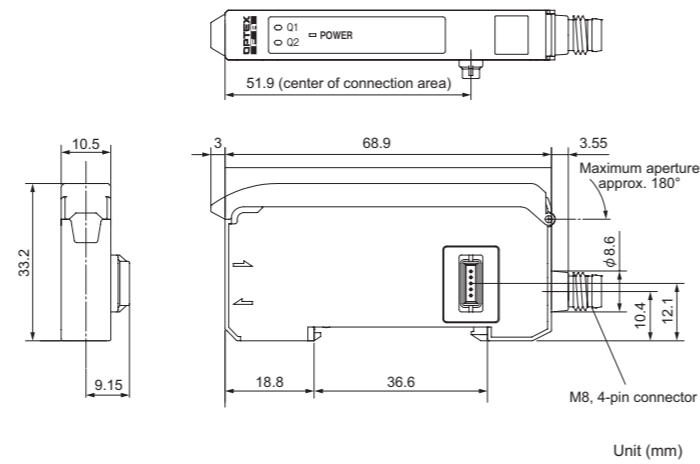

3. I/O Circuit Diagrams

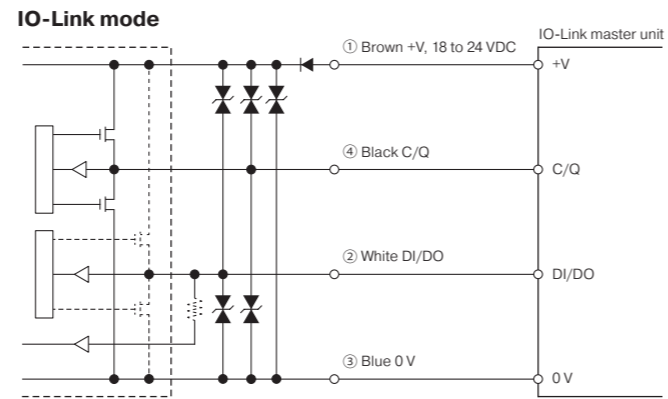

SIO mode (standard I/O mode) with push-pull

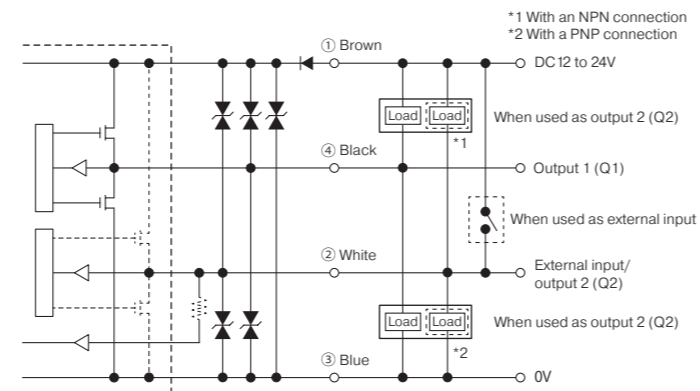

M8 connector pin numbers

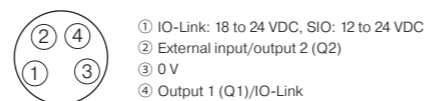

4. Part Names

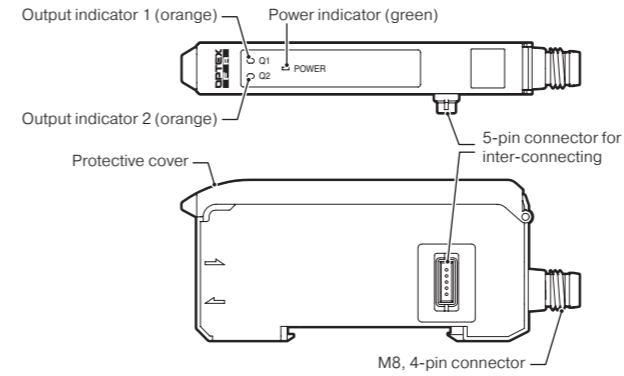

5. Lists of Cables and Connectable Models

Connector cables

(For UC2-IOL and D3RF/D3WF/D4RF series connector types)

Series name	Model	Type
M84CN series (M8, 4-pin connector cable) *This is required when four or more D3RF/D3WF/D4RF connector type main units are inter-connected.	M84CN-2S	2 m long
	-5S	5 m long
	-10S	10 m long

Connectable Models

Product Category	Series name	Type
Fiber amplifiers	D3RF series (red light source)	Inter-connection main unit Inter-connection expansion unit
	D3WF series (white light source)	Inter-connection main unit Inter-connection expansion unit
	D4RF series (red light source)	Standard inter-connection main unit Standard inter-connection expansion unit
		Communication type for inter-connection main unit Communication type for inter-connection expansion unit
Displacement sensor amplifier unit	CDA series	Inter-connection main unit Inter-connection expansion unit
Laser displacement sensor	CD22 series * Use the CDA series to connect.	RS-485 communication type * DSL-1204-G02M connector cable is required to connect to the CDA.
Amplifier connection cable	DSL-1204-G02M	Cable for connecting to the CDA, 2m long
Through-beam edge sensor	TD1 series * Use the CDA series to connect.	

*These are lists of connectable models as of June 2022. For models not listed, contact OPTEX FA.

6. Installation

Installation on DIN rail.

Hook the indicator-side tab on the DIN rail (1), and then press down until the hook locks (2).

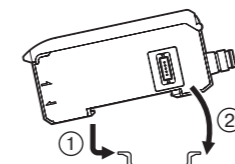

Removal

While pressing the main unit in the direction of (1), lift the indicator side (2) to remove the main unit.

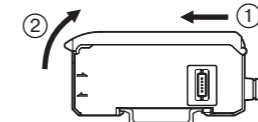

Inter-connecting with fiber amplifiers and displacement sensor amplifier units

To inter-connect all the units, slide the fiber amplifiers and displacement sensor amplifier units along the DIN rail that the UC2 is attached to.

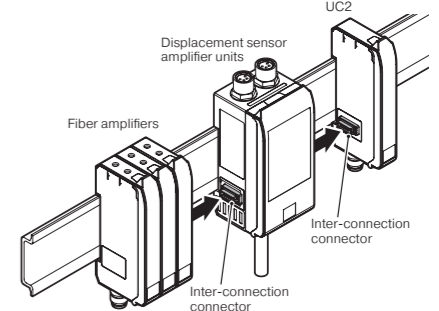

CAUTION

- Be sure to turn off the power before performing this work.
- When inter-connecting, check the ambient temperature and use the units within the operating range for the ambient temperature.
- To prevent short-circuits, be sure to attach the included protective caps for connector types of fiber amplifiers to connecting terminals that are not in use. For cable types, prevent lead wires that are not in use from connecting to the other terminals by, for example, cutting these lead wires and wrapping them individually with insulating tape.
- Do not remove these units/amplifiers from the DIN rail while multiple units are inter-connected.

Installing end plates (sold separately)

To prevent the inter-connected units from coming loose, attach end plates (sold separately; model: BEF-EB01-W190) to the DIN rail so that they surround the inter-connected units and fix the end plates in place with screws.

Orient the end plates so that the product side is against the unit and the fiber amplifiers, making sure to attach the left and right sides in opposite orientations. Attach the end plates by hooking the notched side on the DIN rail first, as shown in the following diagram. Use a tightening torque of 0.9 N·m or less.

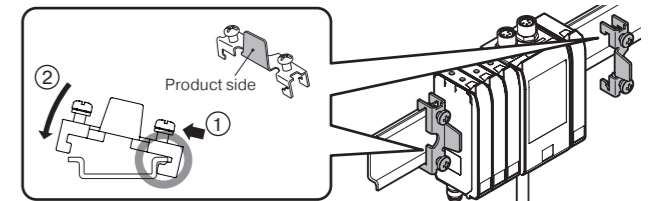

CAUTION

When inter-connecting the unit to D3RF/D3WF/D4RF series fiber amplifiers and to CDA series displacement sensor amplifier units, be sure to connect the inter-connection main unit on the left end (ID = 1). If an inter-connection expansion unit is connected on the left end, the inter-connection connector will be exposed, causing interference with the end plate. Also, fouling on or damage to the inter-connection connector may damage the fiber amplifiers.

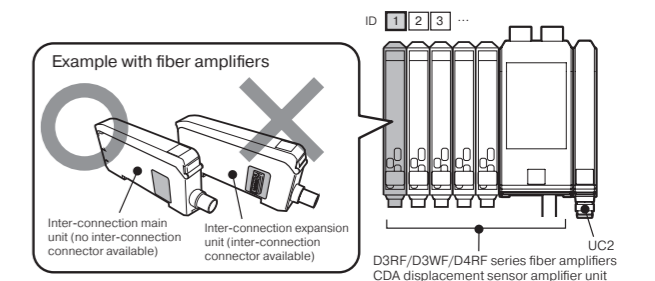

7. Connecting

Connecting the connector cable (sold separately)

Use M84CN-□S M8 connector cable to connect to the IO-Link master unit. Check the orientation of the connector pins on the unit side and on the connector cable side and attach the cable correctly.

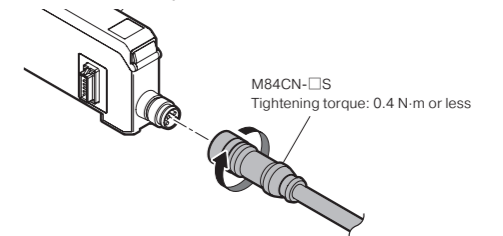

The UC2 operates with a supply voltage of 18 to 24 VDC (12 to 24 VDC in SIO mode). Be sure to check the wiring to the IO-Link master unit and to the power supply device because incorrect wiring may cause a fire or damage the product.

Connecting UC2 to CDA units (connecting to CD22 and TD1 units)

To connect the UC2 to CD22 series laser displacement sensors and to TD1 series through-beam edge sensors, connect through CDA series displacement sensor amplifier units.

<Connection example>

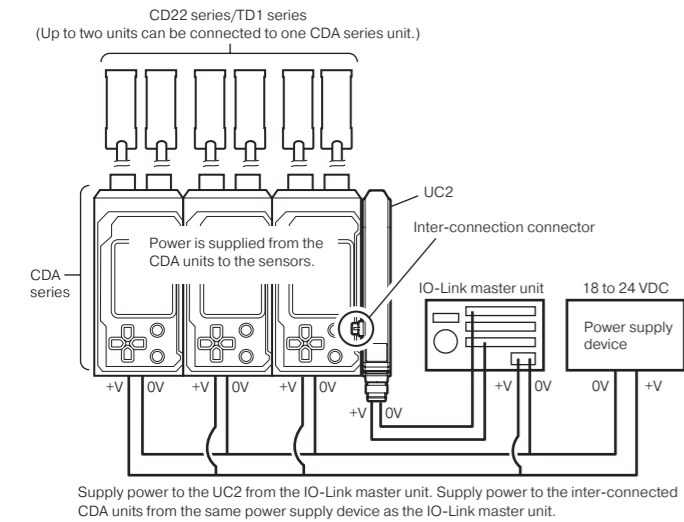

CAUTION

- The CDA series power supply must be connected to a power supply that is separate from that for the UC2 and is the same as that for the IO-Link master unit.
- Power is supplied to the CD22 series and to the TD1 series from the CDA series. The UC2 can be inter-connected to CDA series main units and expansion units.
- When inter-connecting the UC2 to the CDA series, be sure to inter-connect the inter-connection main unit on the left end. If an inter-connection expansion unit is connected on the left end, the inter-connection connector will be exposed, damaging the product.
- Up to eight CDA series units can be inter-connected. The number of output information and receiving distance information varies depending on the setting. Refer to the index list for details.
- Ensure that the length of the power cable to the unit and to the CDA series is 20 m or less.
- The operating temperature of the CDA series expansion unit (CDA-S) and the load current of the control output are restricted by the connected main unit (CDA-M, CDA-DM2) as below.

<CDA-M+CDA-S>	
Operating temperature	-25 to +50°C
Load current of control output	Up to 100mA per output channel (Up to 2A including self-consumption)
Number of connected units	1 unit (Only CDA-M) 2 to 8 units

<CDA-DM2+CDA-S>		
Operating temperature	-25 to +50°C	-20 to +45°C
Load current of control output	Up to 100mA per output channel	Up to 20mA per output channel
Number of connected units	1 unit (Only CDA-DM2)	2 to 8 units

Connecting UC2 to D3RF/D3WF/D4RF series

Use the inter-connection connectors to connect the UC2 to D3RF/D3WF/D4RF series fiber amplifiers.

Connecting power supply wires

When three or less fiber amplifiers are inter-connected to the UC2, the fiber amplifiers operate with the power supplied from the inter-connection connector of the UC2. When four or more fiber amplifiers are inter-connected to the UC2, connect the inter-connection main unit on the left end to the same power supply as the IO-Link master unit.

<Connection example>

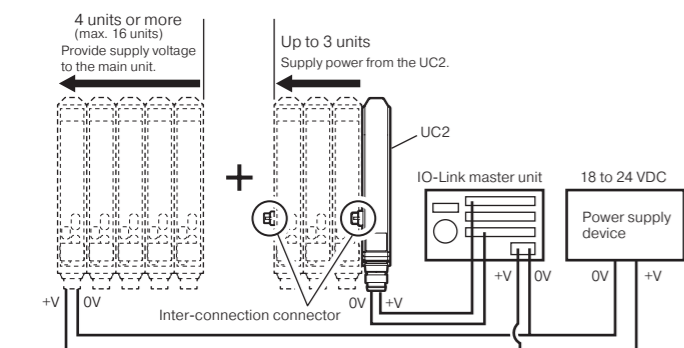

Fiber amplifier inter-connection order

When inter-connecting the UC2 to D3RF/D3WF/D4RF series fiber amplifiers, connect D4RF, D3WF, and D3RF in this order from the side closer to the UC2.

<Connection example>

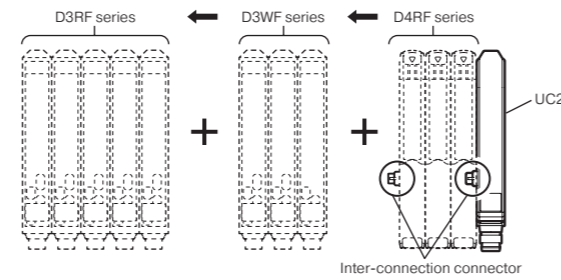

CAUTION

- When inter-connecting the unit to fiber amplifiers, be sure to connect an inter-connection main unit on the left end. If an inter-connection expansion unit is connected on the left end, the inter-connection connector will be exposed, damaging the product.
- A total of up to 16 D3RF/D3WF/D4RF series fiber amplifiers can be inter-connected. The number of output information and receiving light level information varies depending on the setting. Refer to the index list for details.
- Ensure that the length of the power cable to the unit and to the fiber amplifiers is 20 m or less.
- When using a cable type fiber amplifier, perform insulation processing to prevent the power supply wires (brown/blue) from short-circuiting. Short-circuits may lead to device damage. Furthermore, in the case of connector type units, connect the included black cap to the M8 connector when the connector cable is not connected to prevent the pins from short-circuiting.
- The operating temperature and the load current of control output are restricted by the number of connected units as below.

D3RF/D3WF series

Number of connected unit	1 to 3 unit(s)	4 to 8 units	9 to 16 units
Operating temperature	-25 to +55°C	-25 to +50°C	-25 to +45°C
Load current of control output	100 mA	50 mA	20 mA

D4RF series

Number of connected unit	1 unit	2 units	3 to 5 units	6 to 16 units
Operating temperature	-25 to +55°C	-25 to +55°C	-25 to +50°C	-25 to +45°C
Max. load current per output	100 mA	20 mA	20 mA	20 mA
	1 output setting	50 mA	10 mA	10 mA
	2 outputs setting			

Connecting UC2 to a combination of CDA series and D3RF/D3WF/D4RF series units

When inter-connecting the UC2 to CDA displacement sensor amplifier units and D3RF/D3WF/D4RF series fiber amplifiers, connect CDA, D4RF, D3WF, and D3RF in this order from the side closer to the UC2.

(It is possible to connect D4RF, CDA, D3WF, and D3RF in that order as well.)

<Connection example>

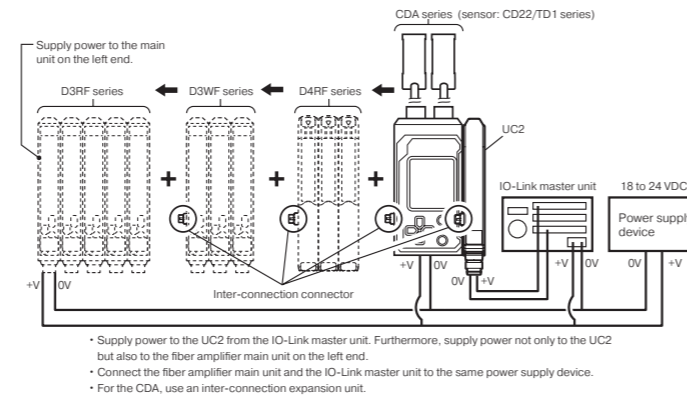

CAUTION

- Supply power to the CDA series and D3RF/D3WF/D4RF series units from the same power supply as that for the IO-Link master unit.
- When inter-connecting the UC2 to the CDA series, be sure to inter-connect the inter-connection main unit on the left end. If an inter-connection expansion unit is connected on the left end, the inter-connection connector will be exposed, damaging the product.
- A total of up to 16 D3RF/D3WF/D4RF series and CDA series units can be inter-connected. (One CDA displacement sensor amplifier unit counts as two sensors.) The number of output information and distance/receiving light level information varies depending on the setting. Refer to the index list for details. (D3RF/D3WF/D4RF series is the receiving light level information and CDA series is distance information.)
- Ensure that the length of the power cable to the unit and to the CDA series is 20 m or less.
- When using a cable type D3RF/D3WF/D4RF series unit, perform insulation processing to prevent the power supply wires (brown/blue) from short-circuiting. Short-circuits may lead to device damage. Furthermore, in the case of connector type units, connect the included black cap to the M8 connector when the connector cable is not connected to prevent the pins from short-circuiting.

8. System Configuration Example

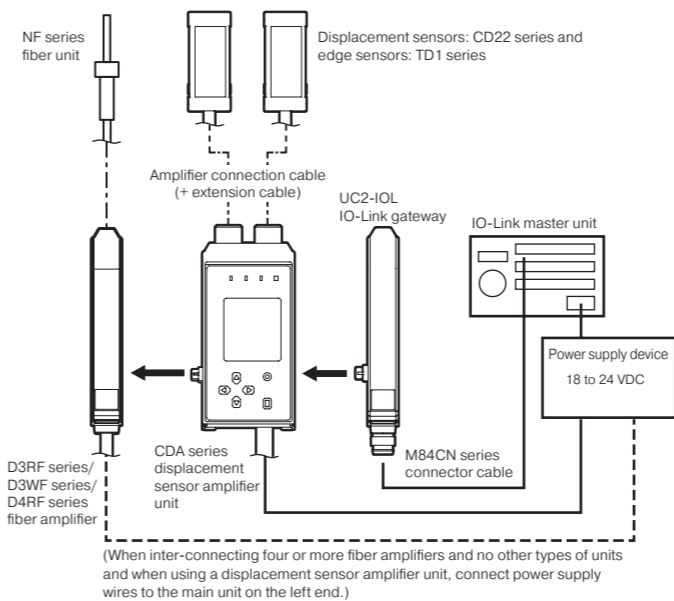

- The UC2 can be inter-connected to up to a total of 16 sensors. (One CDA displacement sensor amplifier unit counts as two sensors.) The number of output information and distance/receiving light level information varies depending on the setting. Refer to the index list for details. (D3RF/D3WF/D4RF series is the receiving light level information and CDA series is distance information.)
- The power supply connections of the devices vary depending on the devices that are connected and on the number of devices that are connected. Check the information under "7. Connecting" and connect the power supplies correctly.

9. Specifications

	Model	UC2-IOL
IO-Link communication specifications	Minimum cycle time	2.2 ms
	Baud rate	COM3 (230.4 kbps)
	ISDU support	Available
	IO-Link revision	1.1
	Number of process input data bytes	32
	Number of process output data bytes	0
Connected devices	IO-Link frame type	F-Sequence Type 2V
	Connectable models	D3RF/D3WF/D4RF series inter-connection main unit and expansion unit CDA series main unit and expansion unit
	Number of connectable units	Up to 16 (One CDA unit requires two spaces.)
Indicators	Connection type	5-pin connector for inter-connection (functions as an inter-connection end unit)
	Indicators	Power indicator (green), SIO: lit at all times, IO-Link: flashing Output indicator x 2 (orange)
Ratings	Supply voltage	SIO: 12 to 24 VDC including 10% of ripple (P-P) IO-Link: 18 to 24 VDC including 10% of ripple (P-P) (SELV and LIM or Class 2)*1
	Current consumption	40 mA max.*2
Control output		Push-Pull x 2 outputs, max. 100 mA/24 VDC (total for 2 outputs) Residual voltage: 1.8 V or less
External input		Teaching input, smart task input
Connection type		Connector type: M8, 4-pin
Circuit stabilization time		With 1 D3RF/D3WF unit inter-connected: 300 ms, with 16 D3RF/D3WF units inter-connected: 350 ms D4RF: 300ms CDA + CD22: 2.5 s CDA + TD1: 350 ms
Protection circuit		Reverse connection protection, overcurrent protection
Environmental resistance	Installation location	Indoor use
	Operating temperature/humidity	-25 to +55°C (no freezing)/35 to 85%RH (no condensation)
	Storage temperature/humidity	-40 to +70°C (no freezing)/35 to 95%RH (no condensation)
	Vibration resistance	10 to 55 Hz; double amplitude 1.5 mm; 2 hours in each of the X, Y, and Z directions
	Shock resistance	Approx. 50 G (500 m/s ²); 3 times in each of the X, Y, and Z directions
	Degree of protection	IP50 (According to IEC 60529, not UL certified)
	Pollution degree	2 or less
Operating altitude	2000 m or less	
Applicable regulations	EMC	EMC directive (2014/30/EU)
	Environment	RoHS directive (2011/65/EU), China RoHS (MIT Order No. 32)
Applicable standard		EN 60947-5-2
Company standards		Noise resistance: Feilen Level 3 cleared
Weight		Approx. 16 g
Material		Housing and protective cover: PC
Included accessories		Instruction manual

*1. Use a Class 2 power supply or a power supply that conforms to the SELV circuit (Safety Extra-Low Voltage) and the LIM circuit (Limited Energy Circuit).
*2. Not including control output load current.

UL Satisfaction Ratings

*Depending on the number of fiber amplifiers and displacement sensor amplifier units connected to the UC2, the total load current of the control output and the ambient temperature are limited as follows:



When power is supplied to fiber sensor and/or displacement sensor amplifiers in parallel

D3RF/D3WF series: up to 3 units
Input: 12-24 VDC, Max. 0.14 A Class 2
Output: 12-24 VDC, Max. 0.1 A Class 2
Maximum Ambient Temperature 55 °C

D3RF/D3WF/D4 series: up to 2 units
Input: 12-24 VDC, Max. 0.14 A Class 2
Output: 12-24 VDC, Max. 0.1 A Class 2
Maximum Ambient Temperature 55 °C

D3RF/D3WF series and CDA-M/CDA-S: up to 8 units
Input: 12-24 VDC, Max. 0.14 A Class 2
Output: 12-24 VDC, Max. 0.1 A Class 2
Maximum Ambient Temperature 50 °C

D3RF/D3WF/D4 series: up to 5 units
Input: 12-24 VDC, Max. 0.14 A Class 2
Output: 12-24 VDC, Max. 0.1 A Class 2
Maximum Ambient Temperature 50 °C

D3RF/D3WF series: up to 16 units
Input: 12-24 VDC, Max. 0.08 A Class 2
Output: 12-24 VDC, Max. 0.04 A Class 2
Maximum Ambient Temperature 45 °C

D3RF/D3WF/D4 series and CDA series: up to 8 units
Input: 12-24 VDC, Max. 0.14 A Class 2
Output: 12-24 VDC, Max. 0.1 A Class 2
Maximum Ambient Temperature 45 °C

D3RF/D3WF/D4 series: up to 16 units
Input: 12-24 VDC, Max. 0.08 A Class 2
Output: 12-24 VDC, Max. 0.04 A Class 2
Maximum Ambient Temperature 40 °C

When power is supplied only to a UC2-IOL unit

D3RF/D3WF/D4 series: up to 2 units
Input: 12-24 VDC, Max. 0.284 A Class 2
Output: 12-24 VDC, Max. 0.1 A Class 2
Maximum Ambient Temperature 55 °C

D3RF/D3WF series: up to 3 units
Input: 12-24 VDC, Max. 0.296 A Class 2
Output: 12-24 VDC, Max. 0.04 A Class 2
Maximum Ambient Temperature 55 °C

D3RF/D3WF/D4 series: up to 3 units
Input: 12-24 VDC, Max. 0.276 A Class 2
Output: 12-24 VDC, Max. 0.04 A Class 2
Maximum Ambient Temperature 50 °C

One D3RF/D3WF/D4 series and one CDA series
Input: 12-24 VDC, Max. 0.292 A Class 2
Output: 12-24 VDC, Max. 0.1 A Class 2
Maximum Ambient Temperature 50 °C

This device complies with part 15 of the FCC Rules.

Operation is subject to the following two conditions: (1) This device may not cause harmful interference, and (2) this device must accept any interference received, including interference that may cause undesired operation.

* This equipment has been tested and found to comply with the limits for a Class A digital device, pursuant to part 15 of the FCC Rules. These limits are designed to provide reasonable protection against harmful interference when the equipment is operated in a commercial environment. This equipment generates, uses, and can radiate radio frequency energy and, if not installed and used in accordance with the instruction manual, may cause harmful interference to radio communications. Operation of this equipment in a residential area is likely to cause harmful interference in which case the user will be required to correct the interference at his own expense.

- Support for the China RoHS directive

For details on the support for the China RoHS directive (the Administrative Measure on the Control of Pollution Caused by Electronic Information Products), see the following website:
https://www.optex-fa.com/rohs_cr/



OPTEX FA CO., LTD.

[Headquarters]
91 Chudoji-Awata-cho, Shimogyo-ku, Kyoto 600-8815 JAPAN
TEL +81-75-325-1314 FAX +81-75-325-2936

<https://www.optex-fa.com>